

W09

DIGITAL ELECTRONIC THERMO-CONTROLLER WITH DEFROSTING FUNCTION



OPERATING INSTRUCTIONS

Vr. 02 (ENG) - 04/12 - cod.: ISTR-MW09-ENG02

ASCON TECNOLOGIC S.r.l.

VIA INDIPENDENZA 56

27029 VIGEVANO (PV) ITALY

TEL.: +39 0381 69871

FAX: +39 0381 698730

<http://www.ascontecnologic.com>

e-mail: info@ascontecnologic.com

FOREWORD



This manual contains the information necessary for the product to be installed correctly and also instructions for its maintenance and use; we therefore recommend that the utmost attention is paid to the following instructions and to save it.

This document is the exclusive property of ASCON TECNOLOGIC which forbids any reproduction and divulgation, even in part, of the document, unless expressly authorized.

ASCON TECNOLOGIC reserves the right to make any formal or functional changes at any moment and without any notice.

Whenever a failure or a malfunction of the device may cause dangerous situations for persons, thing or animals, please remember that the plant has to be equipped with additional devices which will guarantee safety.

ASCON TECNOLOGIC and its legal representatives do not assume any responsibility for any damage to people, things or animals deriving from violation, wrong or improper use or in any case not in compliance with the instrument's features.

INDEX

1	INSTRUMENT DESCRIPTION
1.1	GENERAL DESCRIPTION
1.2	FRONT PANEL DESCRIPTION
2	PROGRAMMING
2.1	FAST PROGRAMMING OF SET POINT
2.2	STANDARD MODE PARAMETERS PROGRAMMING
2.3	PARAMETER PROTECTION USING THE PASSWORD
2.4	CUSTOMIZED MODE PARAMETER PROGRAMMING (PARAMETERS PROGRAMMING LEVEL)
2.5	RESET PARAMETERS TO DEFAULT VALUE/LEVEL
2.6	KEYBOARD LOCK FUNCTION
3	INFORMATION ON INSTALLATION AND USE
3.1	PERMITTED USE
3.2	MECHANICAL MOUNTING
3.3	ELECTRICAL CONNECTIONS
3.4	ELECTRICAL WIRING DIAGRAM
4	FUNCTIONS
4.1	ON / STAND-BY FUNCTION
4.2	MEASURING AND VISUALIZATION
4.3	TEMPERATURE CONTROL
4.4	COMPRESSOR PROTECTION FUNCTION AND DELAY AT POWER-ON
4.5	DEFROST CONTROL
4.5.1	MANUAL DEFROST
4.5.2	DEFROST DISPLAY LOCK
4.6	ALARM FUNCTIONS
4.6.1	TEMPERATURE ALARMS
4.7	PARAMETERS CONFIGURATION BY "A01"
5	PROGRAMMABLE PARAMETERS TABLE
6	PROBLEMS , MAINTENANCE AND GUARANTEE
6.1	SIGNALLING
6.2	CLEANING
6.3	GUARANTEE AND REPAIRS
7	TECHNICAL DATA
7.1	ELECTRICAL DATA
7.2	MECHANICAL DATA
7.3	MECHANICAL DIMENSIONS AND MOUNTING
7.4	FUNCTIONAL DATA
7.5	INSTRUMENT ORDERING CODE

1 - INSTRUMENT DESCRIPTION

1.1 - GENERAL DESCRIPTION

The model W09 is a digital electronic thermocontroller that is typically used in cooling applications that have temperature control with ON/OFF mode and defrosting control with intervals time by stopping compressor.

The instrument has one relay output and one input for PTC or NTC temperature probes, in addition can be equipped with an internal buzzer that is the sound system for alarms.

1.2 - FRONT PANEL DESCRIPTION

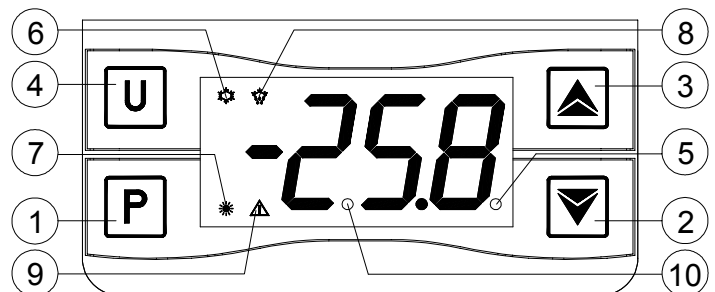

1 - Key P : Used for setting the Set point (press and release) and for programming the function parameters (hold pressed for 5 sec.) In programming mode is used to enter in parameters edit mode and confirm the values.

In programming mode it can be used together with the UP key to change the programming level of the parameters.

When the keyboard is locked it can be used together with the UP (hold pressed for 5 sec.) key to unlock the keyboard.

2 - Key DOWN : In programming mode is used for decreasing the values to be set and for selecting the parameters.

3 - Key UP/DEFROST : In normal mode can be used to start/stop manual defrosting (hold pressed for 5 sec.).

In programming mode is used for increasing the values to be set and for selecting the parameters.

In programming mode can be used together with key P to change parameters level.

Pressed together with the key P for 5 sec. allow the keyboard unlock

4 - Key U : Used (press and release) for visualising the instrument variables (measured temperatures etc.) .

In programming mode can be used to come back in normal mode (hold for 2 sec.).

It can also be programmed via the parameter "t.UF"

In normal mode and if par. "t.UF" = 4 it can be used to turning on and off (stand-by) the device (hold pressed for 1 sec.)

5 - Led SET : In normal mode it serves to indicate when a key is pressed.

In programming mode indicates the programming level of the parameters.

6 - Led OUT - COOL : Indicates the output status (compressor or temperature control device) when the instrument is programmed for cooling operation; on (on), off (off) or inhibited (flashing).

7 - Led OUT - HEAT : Indicates the output status (compressor or temperature control device) when the instrument is programmed for heating operation; on (on), off (off) or inhibited (flashing).

8 - Led DEFROST : Indicates defrosting in progress (on)

9 - Led ALARM : Indicates the alarm status (on), off (off) and silenced (flashing)

10 - Led Stand-By: Indicate the Stand-by status.

2 - PROGRAMMING

2.1 - FAST PROGRAMMING OF SET POINT

Press the key P then release it and the display will show "SP" alternating with the set value.

To change it press the UP key to increase the value or DOWN to decrease it.

These keys increase or decrease the value one digit at a time, but if the button is pressed for more than one second the value increase or decreases rapidly, and after two seconds pressed, the speed increases even more to all the desired valued to be reached rapidly.

When the desired value is set press the key P to exit from Set Point programming mode.

Exiting the Set mode is achieved by pressing the P key or automatically if no key is pressed for 10 seconds. After that time the display returns to the normal function mode.

2.2 - STANDARD MODE PARAMETERS PROGRAMMING

To access the instrument's function parameters when password protection is disable, press the key P and keep it pressed for about 5 seconds, after which the display will visualised the code that identifies the first parameter.

Using the UP and DOWN keys, the desired parameter can be selected and pressing the P key, the display will alternately show the parameter code and its setting that can be changed with the UP and DOWN keys.

Once the desired value has been set, press the key P again: the new value will be memorised and the display will show only the code of the selected parameter.

Pressing the UP and DOWN keys, it is possible to select another parameter and change it as described.

To exit the programming mode, do not press any key for about 30 seconds, or keep the U key pressed for 2 sec. until it exits the programming mode.

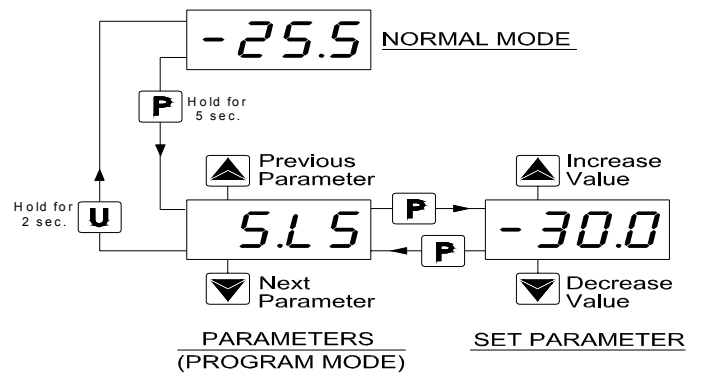

2.3 - PARAMETER PROTECTION USING THE PASSWORD

The instrument has a parameter protection function using a password that can be personalised, through the "t.PP" parameter. If one wishes to have this protection, set the password number desired in the parameter "t.PP".

When the protection is activate, press the P key to access the parameters and keep it press for about 5 seconds, after which the display will show "r.P".

At this point press P, the display show "0", using the UP and DOWN keys, set the password number programmed and press the key P.

If the password is correct, the display will visualise the code that identifies the first parameter and it will be possible to program the instrument in the same ways described in the previous section.

Protection using a password can be disabled by setting the parameter "t.PP" = 0F.

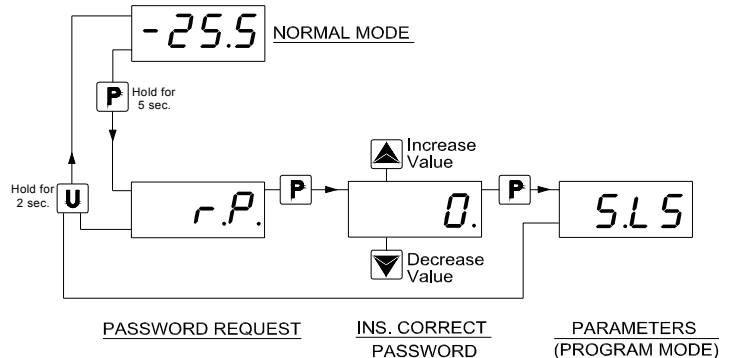

Note: If the Password gets lost, just swith off and on the instrument supply, push P key during the initial test and keeping the key pressed for 5 seconds.

In this way it's possible to have access to all the parameters, verify and modify the par. "t.PP".

2.4 - CUSTOMIZED MODE PARAMETER PROGRAMMING (PARAMETERS PROGRAMMING LEVEL)

The password protection hides all the configuration parameters behind a factory set password to avoid unwanted changes being made to the programming of the controller.

To make a parameter accessible without having to enter the password when "t.PP" password protection is activate follows this procedure.

Enter the programming using the Password "t.PP" and select the parameter which is desired to be accessible with no password protection.

Once the parameter has been selected, if the SET led is blinking, this means that the parameter is programmable by entering the password (it's then "protected") if it's instead on, this means the parameter is programmable without password (not protected).

If you want to change the accessibility of the parameter push P key, keep it pressed and press together also the key UP.

The led SET will change its state indicating the new access level of the parameter (on = not protected; blinking = protected by password).

In case some parameters are not protected, when one tries to have access at the programming, the display will show all the

parameters not protected and the par. "r.P" (through which will be possible to have access to the "protected" parameters.)

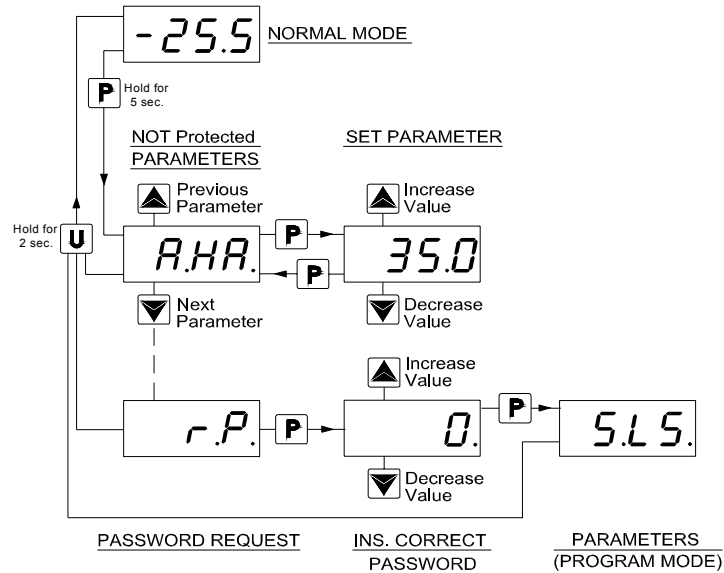

2.5 - RESET PARAMETERS TO DEFAULT VALUE/LEVEL

The instrument allows the reset of the parameters to values programmed in factory as default.

To restore to the values of default the parameters set the value -48 to "r.P" password request.

Once confirmed the password with the key P the display it shows "---" for 2 sec. therefore the instrument effects the parameters reset

2.6 - KEYBOARD LOCK FUNCTION

On the instrument it's possible to lock completely the keyboard.

This function is particularly useful when the regulator is reachable by the users and it's desired to avoid any modification.

To activate the keyboard lock it's enough program the par. "t.Lo" to a different value to 0F.

The value program to this parameter it is the time of inactivity of the keys after which the keyboard will be locked.

Insofar not pressing any key for the time "t.Lo" the instrument automatically disable the normal functions of the keys.

When the keyboard is lock, if any of the key is pushed, on the display will appear "Ln" to indicate the active lock.

To unlock the keyboard it's enough to contemporarily push key P and UP and keep them pushed for 5 sec., after which the label "LF" will appear on the display and all the keys functions will be available again.

3 - INFORMATION ON INSTALLATION AND USE



3.1 - PERMITTED USE

The instrument has been projected and manufactured as a measuring and control device to be used according to EN60730-1 for the altitudes operation until 2000 ms. The use of the instrument

for applications not expressly permitted by the above mentioned rule must adopt all the necessary protective measures. The instrument CANNOT be used in dangerous environments (flammable or explosive) without adequate protection.

The instrument used with NTC 103AT11 probe (identifiable by the printed code "103AT-11" visible on the sensor part) is compliant with standard EN 13485 ("Thermometers for measuring the air and product temperature for the transport, storage and distribution of chilled, frozen, deep-frozen/quick-frozen food and ice cream") with the following classification: [EN13485 air, S, A, 2, - 50°C +90°C]

Remember that the end user must periodically checks and verify the thermometers in compliance with standard EN 13486.

The installer must ensure that EMC rules are respected, also after the instrument installation, if necessary using proper filters. Whenever a failure or a malfunction of the device may cause dangerous situations for persons, thing or animals, please

remember that the plant has to be equipped with additional devices which will guarantee safety.

3.2 - MECHANICAL MOUNTING

The instrument, in case 75 x 122 mm, is designed for independently wall mounting by screws.

Once installed the instrument remember to close the frontal part and fixing it with the 2 provided screws so that the opening is possible only using a tool.

Avoid placing the instrument in environments with very high humidity levels or dirt that may create condensation or introduction of conductive substances into the instrument.

Ensure adequate ventilation to the instrument and avoid installation in containers that house devices which may overheat or which may cause the instrument to function at a higher temperature than the one permitted and declared.

Connect the instrument as far away as possible from sources of electromagnetic disturbances such as motors, power relays, relays, solenoid valves, etc.

3.3 - ELECTRICAL CONNECTION

Carry out the electrical wiring by connecting only one wire to each terminal, according to the following diagram, checking that the power supply is the same as that indicated on the instrument and that the load current absorption is no higher than the maximum electricity current permitted. As the instrument is built-in equipment or plant with permanent connection inside, it is not equipped with either switches or internal devices to protect against overload of current: the installation will include an overload protection and a two-phase circuit-breaker, placed as near as possible to the instrument, and located in a position that can easily be reached by the user and marked as instrument disconnecting device which interrupts the power supply to the equipment. It is also recommended that the supply of all the electrical circuits connected to the instrument must be protect properly, using devices (ex. fuses) proportionate to the circulating currents (see Tech. Data for details). It is strongly recommended that cables with proper insulation, according to the working voltages and temperatures, be used. Furthermore, the input cable of the probe has to be kept separate from line voltage wiring. If the input cable of the probe is screened, it has to be connected to the ground with only one side. We recommend that a check should be made that the parameters are those desired and that the application functions correctly before connecting the outputs to the actuators so as to avoid malfunctioning that may cause irregularities in the plant that could cause damage to people, things or animals.

3.4 - ELECTRICAL WIRING DIAGRAM

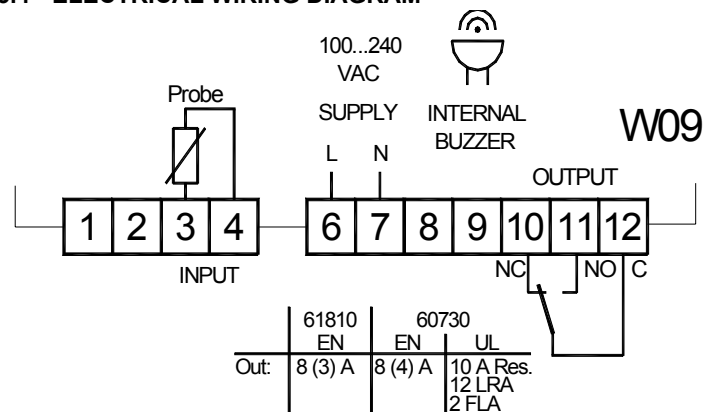

4 - FUNCTIONS

4.1 - ON / STAND-BY FUNCTION

The instrument, once powered up, can assume 2 different conditions:

- ON : means that the controller uses the control functions.
- STAND-BY : means that the controller does not use any control function and the display is turned off except for the led Stand-by.

If there is no power, and then power returns, the system always sets itself in the condition it was in before the black-out.

The ON/Stand-by function can be selected using the key U if the parameter "t.UF" = 4.

Pressing the key U for at least 1 sec., it is possible to switch the instrument from the ON status to Stand-by status and vice versa.

4.2 - MEASURING AND VISUALIZATION

Via the parameter "i.SE" it is possible to select the type of probes that one wishes to use and which can be: thermistores PTC KTY81-121 (Pt) or NTC 103AT-2 (nt).

Via the parameter "i.uP", it is possible to select the temperature unit of measurement the desired measurement resolution (C0=°C / 1°; C1=°C / 0.1°; F0=°F / 1°; F1=°F / 0.1°).

The instrument allows the measuring to be calibrated, that can be used for re-calibrating the instrument according to application needs, through the parameters "i.C1".

Using the parameter "i.Ft", it is possible to set the time constant for the software filter for measuring the input values to be able to reduce the sensitivity to measurement disturbances (increasing the time).

The normal visualisation on the display is the measured temperature but it is possible to visualise the highest and lowest peak measurement values; by quickly pressing and releasing key U.

The display will alternately show:

"Lt" and the lowest peak temperature

"Ht" and the highest peak temperature

"Pr1" and the instant measured temperature

When the instrument is switched off, such values are always re-set. However, it is also possible to reset these values if the instrument is switched on by using the DOWN key hold for 3 sec. during peak visualization.

The display will show "---" and peaks memory will be reset.

The exit of this visualisation mode occurs automatically 15 seconds after the last pressing on the key U.

Please remember that visualisation of the probe can be changed by the defrosting display lock function, by using the parameter "d.dL" (see defrost function).

4.3 - TEMPERATURE CONTROL

The regulation of the instrument is ON/OFF and acts on the output depending on the measuring of probe, of the Set Point "SP", the intervention differential "r.d" and the function mode "r.HC".

Depending on the function mode programmed on the parameter "r.HC" the differential is automatically considered by the regulator with positive values for a Refrigeration control ("r.HC=C") or with negative values for a heating control ("r.HC=H").

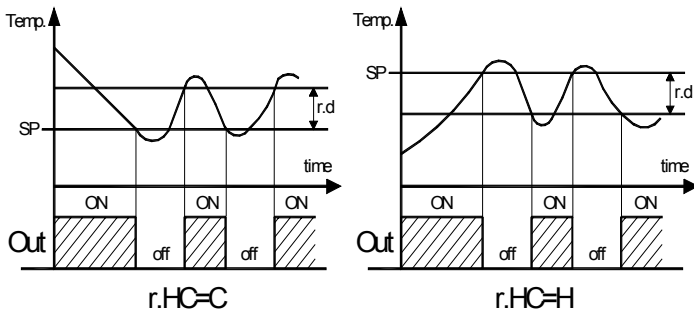

In the event of probe error, it is possible to set the instrument so that the output continues to work in cycles according to the times programmed in the parameter "r.t1" (activation time) and "r.t2" (deactivation time).

If an error occurs on the probe the instrument activates the output for the time "r.t1", then deactivates it for the time "r.t2" and so on whilst the error remains.

Programming "r.t1" = oF the output in probe error condition will remain switched off.

Programming instead "r.t1" to any value and "r.t2" = oF the output in probe error condition will remain switched on.

Remember that the temperature regulation function can be conditioned by the "Compressor Protections", "Delay at power on" and "Desfrost" functions.

4.4 - COMPRESSOR PROTECTION FUNCTION AND DELAY AT POWER-ON

The function "Compressor Protection" aims to avoid close start ups of the compressor controlled by the instrument in cooling applications.

This function foresees 3 time controls on the switching on of the output associated with the temperature regulation request.

The protection consists of preventing the output being switched on during the times set in the parameters "P.P1", "P.P2" and "P.P3" and therefore that any activation occurs only after all the times has finished.

First control (par. "P.P1") foresees a delay to the output activation (switching-on delay).

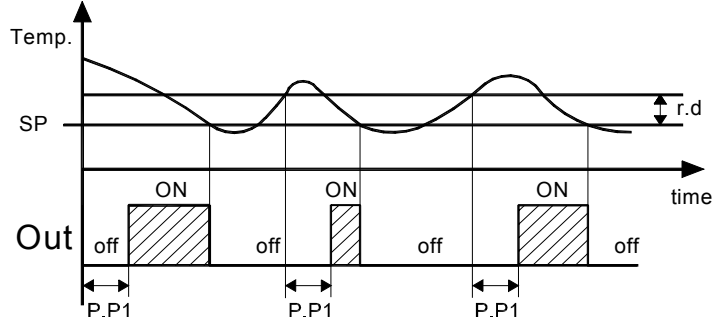

Second control (par. "P.P2") foresees an inhibition to the activation of the output by a time delay that starts when the output is turning off (delay after switching-off).

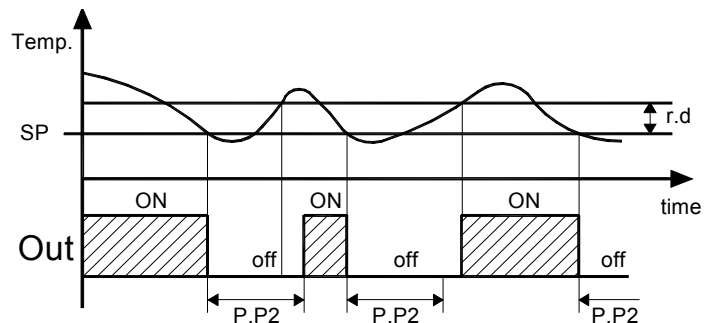

Third control (par. "P.P3") foresees an inhibition to the activation of the output "Out" by a time delay that starts when the output was turning on last time (delay between switching-on).

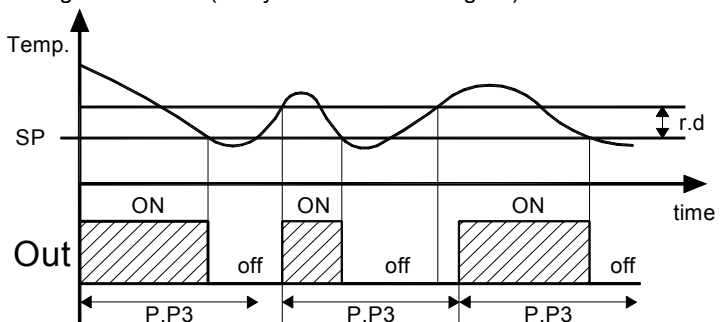

During the output inhibition the led OUT (Cool o Heat) blinking. It is also possible to prevent activation of the output after the instrument is turned on, for the time set in the parameter "P.od". During the power on delay phase, the display shows the indication od, alternating with the normal visualisation. All the functions are disabled by relative parameters = oF.

4.5 - DEFROST CONTROL

The automatic control of defrost, that is by stopping compressor, occurs by interval times

The automatic defrost function is activate when at the parameter "d.di" is set the defrost interval time.

The first defrost after swiching on can be set by par. "d.Sd"

This allows to perform the first defrost to a different interval from "d.di." time.

If it is desired that to every instrument power on a defrost cycle is realized program the par. "d.Sd" = oF.

Instead if is desired all defrost to the same interval program "d.Sd" = "d.di."

Automatic defrost function is disable when "d.di" = oF.

The instrument provides to switch off the output for the time "d.dE" each "d.di" time (of "d.Sd" in case of first defrost after power on)

4.5.1 - MANUAL DEFROST

To start up a manual defrosting cycle, press the key UP/DEFROST when it is not in programming mode and keep it pressed for about 5 seconds after which, if the conditions are correct, the led Defrost will light up and the instrument will carry out a defrosting cycle.

To stop a defrosting cycle, press the key UP/DEFROST during the defrost and keep it pressed for about 5 seconds.

4.5.2 - DEFROST DISPLAY LOCK

Through par. "d.dL" and "A.dA" it's possible to define the display behaviour during defrost.

The "d.dL" parameter permits the display visualization lock on the last temperature reading ("d.dL" = on) during all the defrost cycle until, at the end of defrost, the temperature has not reached the lock value or the value ["SP" + "r.d"] or is elapsed the time setted on par. "A.dA".

Or it permits only the visualization of label "dEF" ("d.dL" = Lb) during the defrost cycle and, after the defrost, of label "PdF" until, at the end of defrost, the temperature has not reached the lock value or the value ["SP" + "r.d"] or is elapsed the time setted on par. "A.dA".

The display will otherwise ("d.dL" = oF) continue to visualize the temperature measured by the probe during the defrost cycle .

4.6 - ALARM FUNCTIONS

The alarm conditions of the instrument are:

- Probe errors "E1", "-E1"
- temperature alarms "Hi" and "Lo"

The alarm functions of the instrument work on the led ALARM and on the internal buzzer, if present and configured via the parameter "o.bu",

The possible selections of the parameter "o.bu" are:

- = oF - Buzzer always disable
- = 1 - Buzzer signal active alarms only
- = 2 - Buzzer signal key pressed only (no alarm)
- = 3 - Buzzer signal active alarms and key pressed

Any active alarm is shown on the instrument display with the lighting up of the ALARM led, the silenced alarm status is shown by the ALARM led flashing .

The buzzer (if "o.bu" = 1 or 3) is activated in alarm and can be disabled (alarm silencing) manually by pressing any key of the instrument .

4.6.1 - TEMPERATURE ALARMS

The temperature alarms work according to the probe measurement, the type of alarm set in the parameter "A.Ay" the alarm thresholds set in parameters "A.HA" (maximum alarm) and "A.LA" (minimum alarm) and the relative differential "A.Ad".

Through the parameter "A.Ay" it is possible to set the alarm thresholds "A.HA" and "A.LA" which must be considered as absolute ("A.Ay"=1) or relative to the Set Point ("A.Ay"=2).

Using some parameters it is also possible to delay the enablement and the intervention of these alarms.

These parameters are:

"A.PA" - is the temperature alarm exclusion time on switching on the instrument if the instrument is in alarm status when it is switched on.

If the instrument is not in alarm status when it is switched on the time "A.PA" it is not considered.

"A.dA" - is the temperature alarm exclusion time at the end of defrosting

"A.At" - is the temperature alarm delay activation time

The temperature alarm is enabled at the end of exclusion time and is enabled after the "A.At" time when the temperature measured by

the probe exceeds or goes below the respective maximum and minimum alarm thresholds.

The alarm thresholds will be the same as those set on the parameters "A.HA" and "A.LA" if the alarms are absolute ("A.Ay"=1)

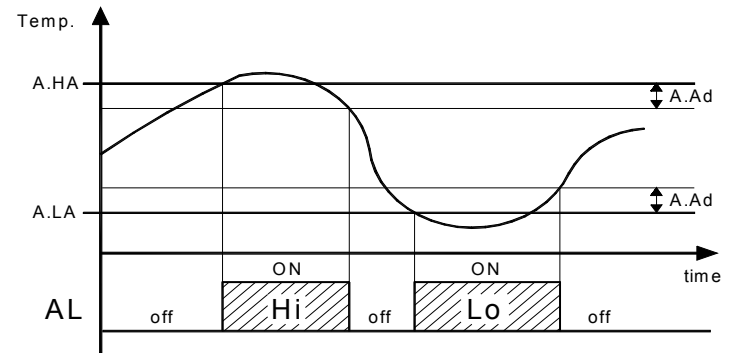

or will be the values ["SP"+"A.HA"] and ["SP"+"A.LA"] if the alarms are relative ("A.Ay"=2).

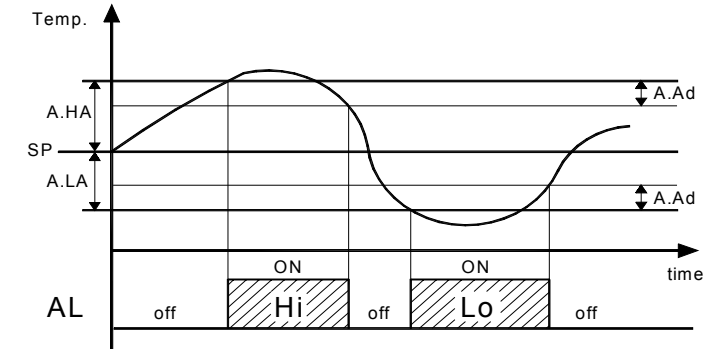

The maximum and minimum temperature alarms can be disabled by setting the relative parameters "A.HA" and "A.LA" = oF.

4.7 - PARAMETERS CONFIGURATION BY "A01"

The instrument is equipped with a connector that allows the transfer from and toward the instrument of the functioning parameters through the device A01 with 5 poles connector.

This device it's mainly useable for the serial programming of the instruments which need to have the same parameters configuration or to keep a copy of the programming of an instrument and allow its rapid retransmission.

The same device A01 allows the USB connection to a PC and through the "TECNOLOGIC UniversalConf" configuration software it is possible to program all the instrument parameters.

To access the connector it is necessary to remove power supply, remove the 2 screws on the upper side of the instrument and therefore remove the plastic cover.

We recommends to supply A01 and the instrument by the provided power adaptor and DO NOT supply the instrument when the cover has been removed because there are live accessible parts at main voltage.

For additional info, please have a look at the A01 instruction manual.

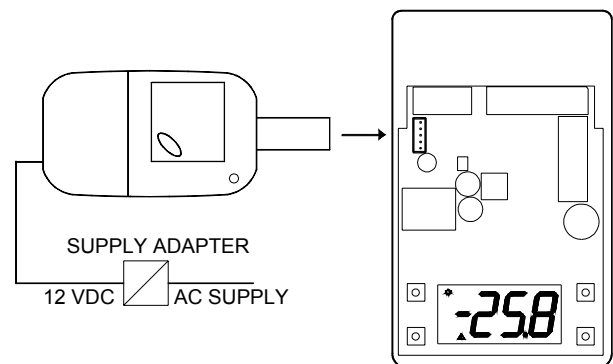

5 - PROGRAMMABLE PARAMETERS TABLE

Here below is a description of all the parameters available on the instrument. Some of them may not be present because depend on the model/type of instrument.

Par.	Description	Range	Def.	Note
S. - parameters relative to Set Point				
1	S.LS	Minimum Set Point	-99.9 ÷ HS	-50.0
2	S.HS	Maximum Set Point	LS ÷ 999	99.9
3	SP	Set Point	LS ÷ HS	0.0
i. -parameters relative to inputs				
4	i.SE	Probes Type	Pt / nt	nt
5	i.UP	Unit of measurement and resolution (decimal point) C0 = °C with 1° res. F0 = °F with 1° res. C1 = °C with 0,1° res. F1 = °F with 0,1° res.	C0 / F0 / C1 / F1	C1
6	i.Ft	Measurement filter	oF ÷ 20.0 sec	2.0
7	i.C1	Probe Calibration	-30.0 ÷ 30.0 °C/°F	0.0
r. - parameters relative to temperature control				
8	r.d	Differential (Hysteresis)	0.0 ÷ 30.0 °C/°F	2.0
9	r.t1	Output activation time for probe error	oF/ 0.01 ÷ 9.59 (min.sec) ÷ 99.5 (min.sec.x10)	oF
10	r.t2	Output deactivation time for probe error	oF/ 0.01 ÷ 9.59 (min.sec) ÷ 99.5 (min.sec.x10)	oF
11	r.HC	Output operating mode H= Heating C= Cooling	H - C	C
d. - parameters relative to defrosting control				
12	d.di	Defrosting interval	oF/ 0.01 ÷ 9.59 (hrs.min.) ÷ 99.5 (hrs.min.x10)	oF
13	d.Sd	Delay first defrost after power-on (oF = Defrost at power-on)	oF/ 0.01 ÷ 9.59 (min.sec) ÷ 99.5 (min.sec.x10)	oF
14	d.dE	Lenght of defrost cycle	oF/ 0.01 ÷ 9.59 (min.sec) ÷ 99.5 (min.sec.x10)	oF
15	d.dL	Defrost display Lock oF= display free on= Lock on temperature Pr1 before defrost Lb= Lock on label "dEF" (during defrosting) and "PdF" (during post-defrosting)	oF - on - Lb	oF
P. parameters relative to compressor protection and power on delay				
16	P.P1	Out delay at switch on	oF/ 0.01 ÷ 9.59 (min.sec) ÷ 99.5 (min.sec.x10)	oF
17	P.P2	Out delay after switch off	oF/ 0.01 ÷ 9.59 (min.sec) ÷ 99.5 (min.sec.x10)	oF
18	P.P3	Out delay between switching-on	oF/ 0.01 ÷ 9.59 (min.sec) ÷	oF

19	P.od	Delay at power on	99.5 (min.sec.x10) oF/ 0.01 ÷ 9.59 (min.sec) ÷ 99.5 (min.sec.x10)	oF
A. - parameters relative to alarms				
20	A.Ay	Temperature alarms Type: 1 = Absolute 2 =Relative to Set	1 / 2 (/ 3 / 4 / 5 / 6 / 7 / 8 = don't use)	1
21	A.HA	High temperature Alarm threshold	oF / -99.9 ÷ 999 °C/°F	oF
22	A.LA	Low temperature Alarm threshold	oF / -99.9 ÷ 999 °C/°F	oF
23	A.Ad	Temperature Alarms Differential	0.0 ÷ 30.0 °C/°F	1.0
24	A.At	Temperature Alarms delay	oF/ 0.01 ÷ 9.59 (min.sec) ÷ 99.5 (min.sec.x10)	oF
25	A.PA	Temperature Alarms delay at power on	oF/ 0.01 ÷ 9.59 (hrs.min.) ÷ 99.5 (hrs.min.x10)	2.00
26	A.dA	Temperature Alarms delay and unlock display delay after defrost	oF/ 0.01 ÷ 9.59 (hrs.min.) ÷ 99.5 (hrs.min.x10)	1.00
o. -parameters relative to buzzer				
27	o.bu	Buzzer function mode oF = disable 1 = active alarms only 2 = key pressed only 3 = active alarms and key pressed	oF / 1 / 2 / 3	3
t. - parameters relative to configuration of the keyboard				
28	t.UF	Function mode key U oF= No function 4= Switch on/Switch off (Stand-by)	oF / 4 (1 / 2 / 3 = don't use)	oF
29	t.Lo	Keyboard lock function delay	oF/ 0.01 ÷ 9.59 (min.sec) ÷ 30.0 (min.sec.x10)	oF
30	t.PP	Access Password to parameter functions	oF ÷ 999	oF

6 - PROBLEMS, MAINTENANCE AND GUARANTEE

6.1 - SIGNALLING

Error	Reason	Action
E1 -E1	The probe may be interrupted (E) or in short circuit (-E), or may measure a value outside the range allowed	Check the correct connection of the probe with the instrument and check the probe works correctly
EPr	Internal EEPROM memory error	Press key P
Err	Fatal memory error	Replace the instrument or ship to factory for repair

Other Signalling:

Message	Reason
od	Delay at power-on in progress
Ln	Keyboard lock
dEF	Defrosting in progress with "d.dL"=Lb
PdF	Post-defrosting in progress with "d.dL"=Lb
Hi	Maximum temperature alarm in progress
Lo	Minimum temperature alarm in progress

6.2 - CLEANING

We recommend cleaning of the instrument only with a slightly wet cloth using water and not abrasive cleaners or solvents.

6.3 - GUARANTEE AND REPAIRS

The instrument is under warranty against manufacturing flaws or faulty material, that are found within 12 months from delivery date. The guarantee is limited to repairs or to the replacement of the instrument.

The eventual opening of the housing, the violation of the instrument or the improper use and installation of the product will bring about the immediate withdrawal of the warranty's effects.

In the event of a faulty instrument, either within the period of warranty, or further to its expiry, please contact our sales department to obtain authorisation for sending the instrument to our company.

The faulty product must be shipped to ASCON TECNOLOGIC with a detailed description of the faults found, without any fees or charge for ASCON TECNOLOGIC, except in the event of alternative agreements.

7 - TECHNICAL DATA

7.1 - ELECTRICAL DATA

Power supply: 100...240 VAC +/- 10%

Frequency AC: 50/60 Hz

Power consumption: 3 VA approx.

Recommended Fuse: instrum. supply: T 200 mA 250V; other circuits: depending on the connected load.

Input/s: 1 input for temperature probes: PTC (KTY 81-121, 990 Ω @ 25 °C) or NTC (103AT-2, 10K Ω @ 25 °C).

Output/s: 1 relay output SPDT

	EN 61810	EN 60730	UL 60730
Out1 - SPDT - 8 A - 1/2HP 250V, 1/3 HP 125 VAC	8 (3) A	8 (4) A	10 A Res., 12 LRA, 2 FLA

Electrical life for relay outputs: 100000 op. (EN60730)

Action type: type 1.B (EN 60730-1)

Overvoltage category: II

Protection class: Class II

Insulation: Reinforced insulation between the low voltage part (supply and relay output) and front panel; Reinforced insulation between the low voltage section (supply H type and relay output) and the extra low voltage section (inputs); Reinforced between supply and relay output.

7.2 - MECHANICAL DATA

Housing: Self-extinguishing plastic, UL 94 V0

Heat and fire resistance category: D

Ball Pressure Test secondo EN60730: accessible parts 75 °C; support live parts 125 °C

Dimensions: 75 x 122 mm, depth 34 mm

Weight: 120 g approx.

Mounting: independently wall mounting

Connections: 2,5 mm² screw terminals block for 0,2...1,5 mm² / AWG 24...16 cables.

Cables outlet: on the back side or lateral side by PG9 cable gland

Degree of front panel protection: IP 40

Pollution situation: 2

Operating temperature: 0 T 50 °C

Operating humidity: < 95 RH% without condensation

Storage temperature: -25 T 60 °C

7.3 - MECHANICAL DIMENSIONS AND MOUNTING [mm]

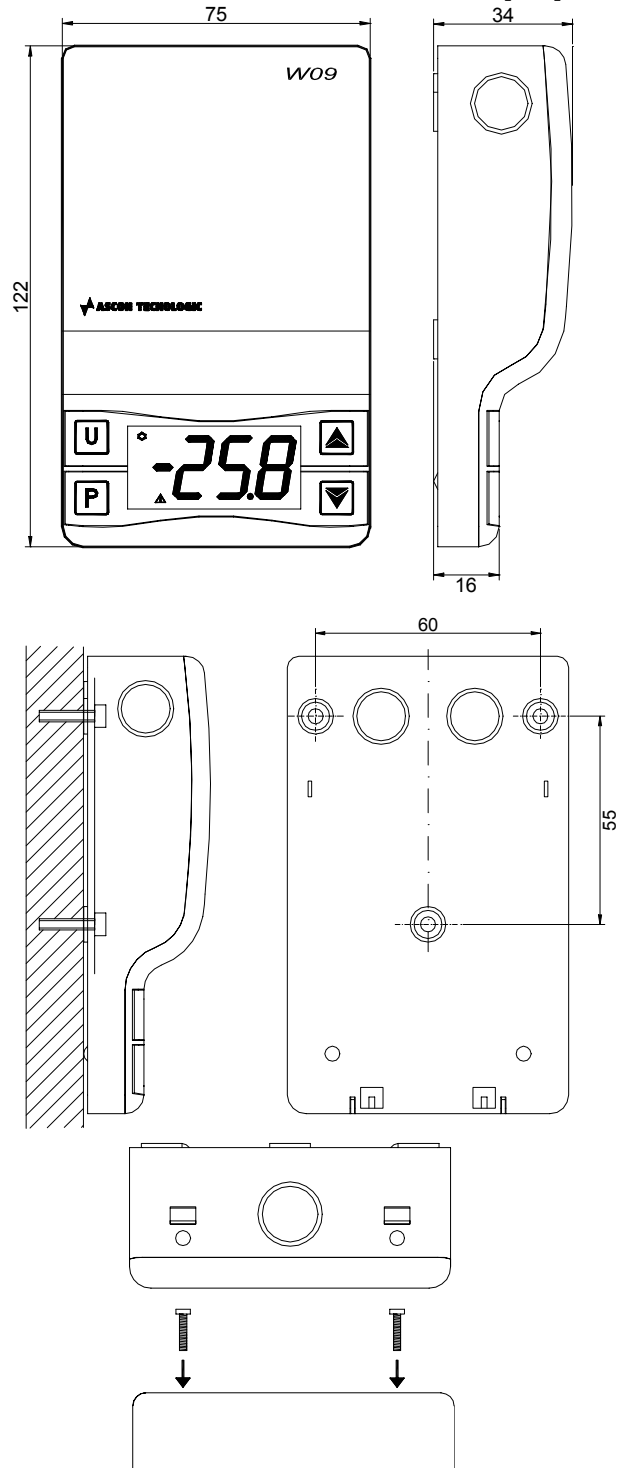

7.4 - FUNCTIONAL FEATURES

Temperature Control: ON/OFF mode

Defrost control: interval cycles by stopping compressor

Measurement range: NTC: -50...109 °C / -58...228 °F; PTC: -50...150 °C / -58 ... 302 °F

Display resolution: 1 ° or 0,1° (range -99.9 ...99.9 °)

Overall accuracy: +/- (0,5 % fs + 1 digit)

Sampling rate: 130 ms.

Display: 3 Digit Red (or Blue as option) h 15,5 mm

Software class and structure: Class A

Compliance: Directive 2004/108/CE (EN55022: class B; EN61000-4-2: 8KV air, 4KV cont.; EN61000-4-3: 10V/m; EN61000-4-4: 2KV supply and relay outputs, 1KV inputs; EN61000-4-5: supply 2KV com. mode, 1 KV diff. mode; EN61000-4-6: 3V);

Directive 2006/95/CE (EN 60730-1, EN 60730-2-9).

Regulation 37/2005/CE (EN13485 air, S, A, 2,- 50°C +90°C with probe NTC 103AT11).

7.5 - INSTRUMENT ORDERING CODE

W09- a b c d e f g h ii jj

a : POWER SUPPLY

H = Supply 100..240 VAC

b : OUT

R = Out Relay SPDT 8A-AC1

c : BUZZER

- = (No)

B = Buzzer

d, e, f, g, h : INTERNAL CODES

ii, jj : SPECIAL CODES