

EWRC 300/500 NT

Controllers for static and ventilated cold rooms



QUICK START

INTRODUCTION

The **Coldface EWRC 300/500 NT** series controls the temperature of a static or ventilated cold room. The instrument controls positive and negative cold rooms and is capable of managing a double evaporator and condenser probes.

Coldface has 3 or 5 configurable relays depending on the model, 2 digital inputs configurable for door switch or other devices. Models are available with clock with yearly calendar and HACCP event logging.

Connection to **TeleviSystem** is possible using the optional module plug-in RS485.

The container is used to install a magnetothermal switch or power contactor.

This summary document contains basic information about the standard models **EWRC 300/500 NT**.

For further information and different configurations, refer to the complete user manual cod. **9MA10258** downloadable free of charge from **www.eliwell.com**.

NAVIGATION DIAGRAM

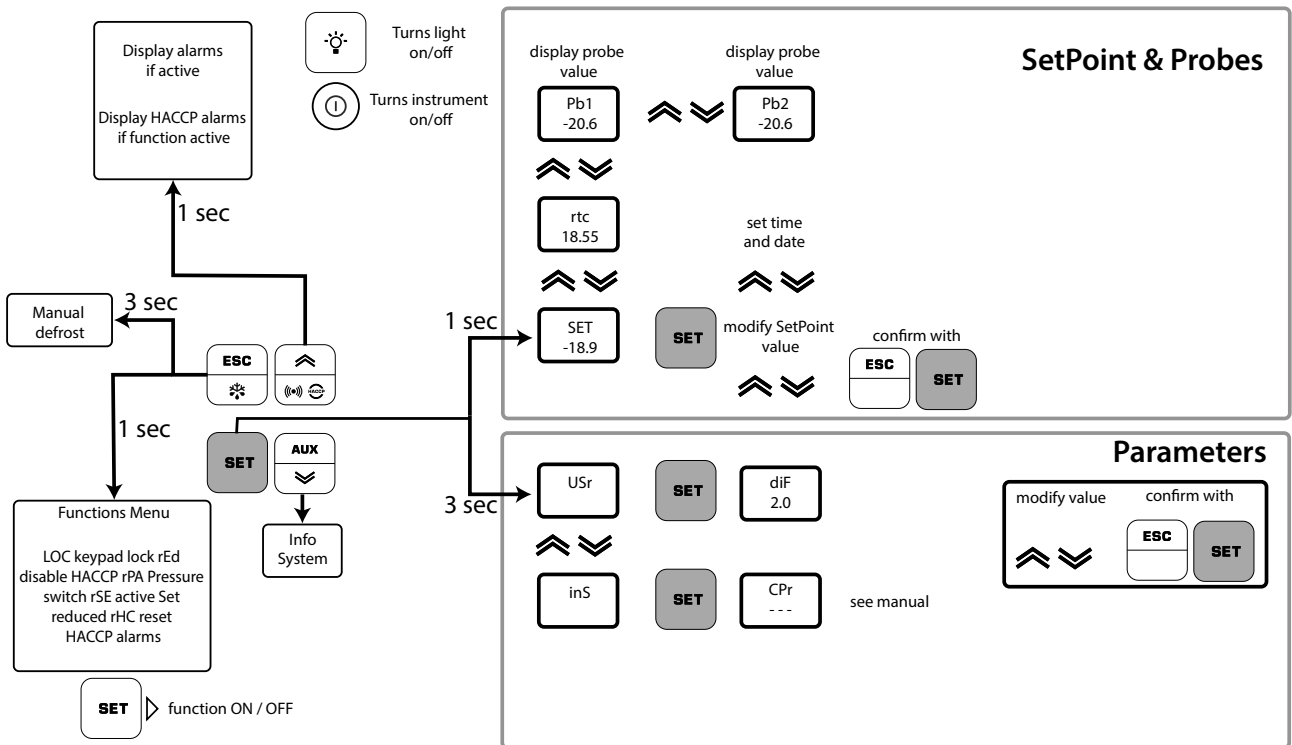

MECHANICAL INSTALLATION

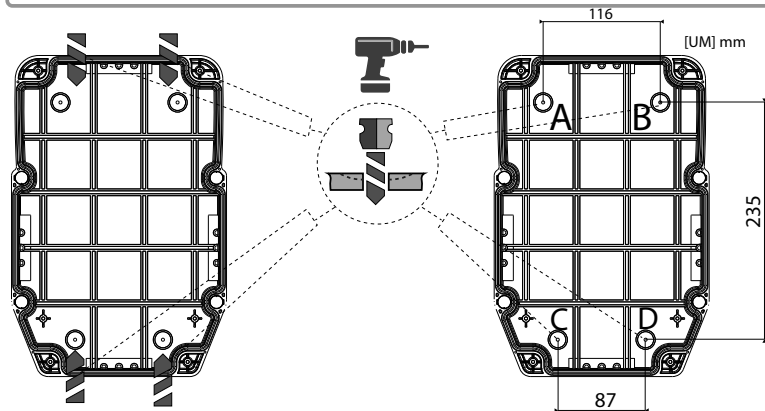
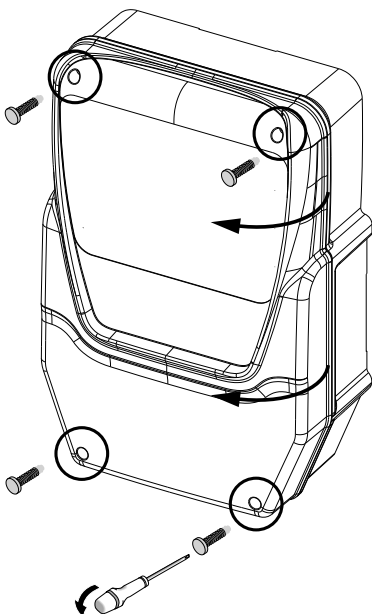

- Take out the 4 screws supplied and then open the cover.
- Drill holes for the high and low voltage cable glands on the sides of the backplate, as shown.
- Check that the cables are inside the box.
- Use suitable cable glands and/or conduit glands that guarantee an airtight seal for all wiring.
- Drill 4 holes (see A...D) in the wall and fix the backplate using 4 screws (not supplied) suited to the wall thickness.
- Insert plug covers TDI 20 (accessory available on request)
- Close the door and screw on the 4 cover screws taking care that the hinges are flush and do not interfere with the closure of the cover.

See cutout at last page.

ELECTRICAL CONNECTIONS

Output relay (default settings)

- **OUT1** relay 1 = Compressor (or liquid line valve)
- **OUT2** relay 2 = Defrost
- **OUT3** relay 3 = Evaporator fan
- **OUT4** relay 4 = Light (EWRC 500 NT only)
- OUT1-4 common-line max 18A
- **OUT5** relay 5 = Alarm/AUX (EWRC 500 NT only)

Probe inputs (default settings)

- **Pb1** = NTC cold room probe
- **Pb2** = NTC defrost end probe
- **Pb3** = Not configured

To switch between NTC/PTC probe types use parameter H00. **SWITCH OFF AND RESTART THE INSTRUMENT** after making the change.

Digital Inputs (default settings)

- **DI1** = Door switch
- **DI2** = not configured

Serial ports

- **TTL** for connection to UNICARD / Copy Card / MFK
- **TTL** for connection to TelevisSystem
- **RS485** available **ONLY** with optional Plugin module for connection to TelevisSystem.

Important! Make sure the appliance is switched off before working on the electrical connections.

- **Probe and digital inputs, OUT5 relay: screw-on terminals pitch 5.01:** electric cables with max. cross-section 2.5 mm² (only one wire per terminal for power connections).
- **Power supply and relay OUT1..OUT4: screw-on terminals pitch 7.62:** electric cables with max. cross-section 4 mm² (only one wire per terminal for power connections).

English

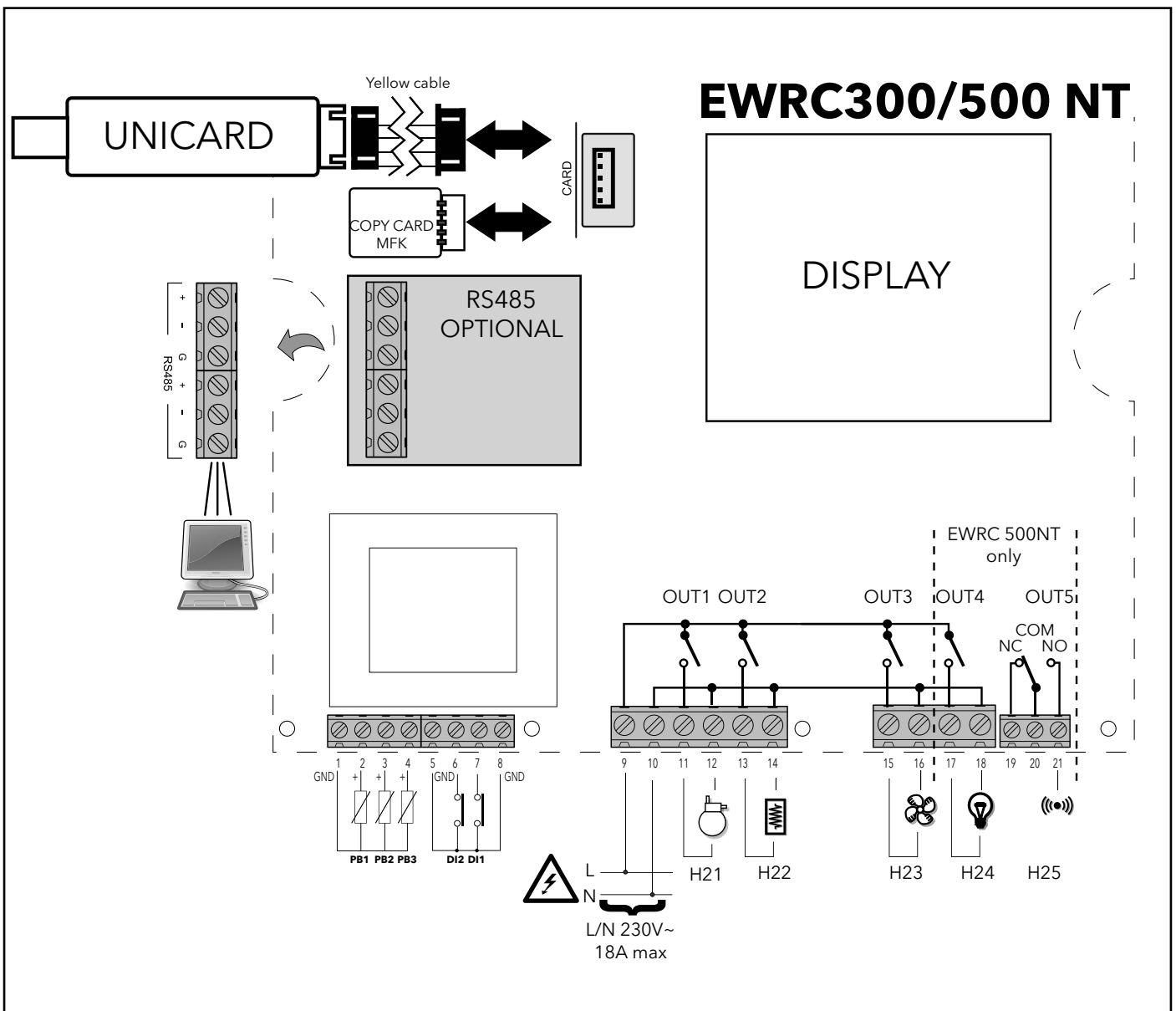

DISPLAY



3-FIGURE UPPER DISPLAY plus the - sign

Display:

- Operating value
- parameters label
- alarms, functions

if Upper display **blinking**

it means that the value of the Lower Display can be modified

4-FIGURE LOWER DISPLAY

Display:

- parameters value
 - probe value
 - function state
- HACCP models**
 - time

English

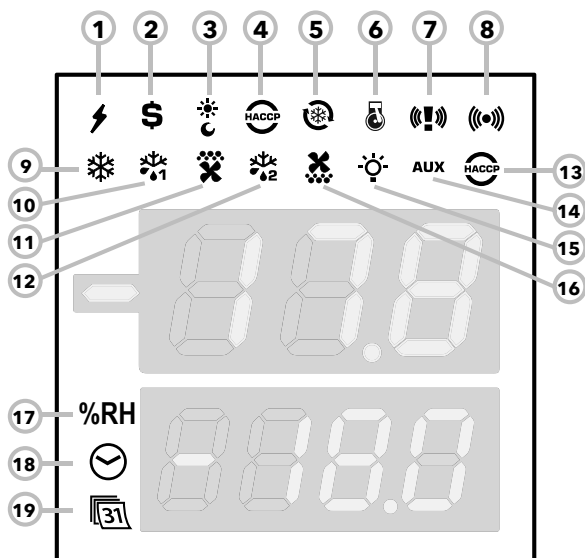

LEDs

N.	LEDs	Colour	description
17	RH	amber	not used
18	TIME	amber	access in case of time display or editing
19	DATA	amber	access in case of date display or editing

N.	LEDs	Colour	ON	BLINKING	OFF
1	POWER SUPPLY	green	Power supply ON	/	Power supply OFF
2	ENERGY SAVING	amber	Energy saving ON	/	Energy saving OFF
3	NIGHT & DAY	amber	Night & Day ON	/	Night & Day OFF
4	HACCP	amber	HACCP menu	/	/
5	DEEP COOLING (DCC)	amber	Deep cooling cycle ON	/	Deep cooling cycle OFF
6	PUMP DOWN	amber	Compressor Pump Down ON	/	Compressor Pump Down OFF
7	PANIC	red	Panic alarm	/	No alarm
8	ALARM	red	Alarm	Silenced	No alarm
9	COMPRESSOR	amber	Compressor ON	delay	Compressor OFF
10	DEFROST 1	amber	defrost	drip	No defrost
11	EVAPORATOR FANS	amber	Fans ON	forced ventilation	Fans OFF
12	DEFROST 2	amber	defrost	drip	No defrost
13	HACCP ALARM	red	HACCP alarm	Not displayed	No alarm
14	AUXILIARY (AUX)	amber	AUX ON	/	AUX OFF
15	LIGHT	amber	Light ON	/	Light OFF
16	CONDENSER FANS	amber	Fans ON	/	Fans OFF

ON: function/alarm ON; OFF: function/alarm OFF

KEYS

No.	KEY	press and release	press and hold for about 3 seconds	NAVIGATION MENU	Notes
A	ESC key Defrost	• Functions Menu	• Manual defrost • Return to Main Menu	• Output	
B	▲ UP Alarms	• Alarms Menu (always visible)	/	• Scroll • Increase values	HACCP alarms only on foreseen models and if present
C	SET	• Display SetPoint / probe values / time (Models with clock) • Confirm values • Access value edit mode (upper display blinking)	• Access Parameters Menu	• Confirm values • Move right	display time Models with clock only
D	▼ DOWN AUX	system INFO See Technical Support	Activate auxiliary function	• Scroll • Decrease values	
E	ON/OFF	/	Switch On/Off device	/	
F	LIGHT	/	Switch light on/off	/	

USER INTERFACE

How to modify the SetPoint

- Press and release the SET key. The upper display will show SEt, the lower display will indicate the current SetPoint value
- Press and release the SET key once more. The upper display will show SEt blinking
- Use the UP & DOWN keys to adjust the Setpoint value
- Press the ESC key several times (or keep it pressed) to return to the normal display

How to read the probe value

- Press and release the SET key. The upper display will show SEt, the lower display will indicate the current SetPoint value
- Press and release the DOWN key. If the RTC clock is present, the time will be shown in the lower display
- Press and release the DOWN key once more. The upper display will show Pb1, the lower display will indicate the value read by the room probe
- Press and release the DOWN key once more to read the value of probe Pb2 and Pb3 if configured
- Press the ESC key to return to the normal display.

How to modify the User Parameters

The user parameters are the most useful parameters and are described in this document, in the section Parameters Table.

- 1) Press and hold the SET key for 3 seconds until the display shows PAr / USr
- 2) Press and release the SET key once more. The upper display will show the first parameter, the lower display will indicate the current parameter value
- 3) Using the UP & DOWN keys, find the parameter that you wish to modify
- 4) Press and release the SET key once more. The upper display will show the name of the blinking parameter
- 5) Use the UP & DOWN keys to adjust the parameter value.
- 6) Press and release SET to save the parameter value
- 7) Return to step 3) or press ESC several times to return to the normal display

USER PARAMETERS TABLE

This section describes the most commonly used parameters which are always visible (the access password PA1 is not enabled by default). For a description of all other parameters, see the user manual. NOTE: the user parameters ARE NOT divided into sub-folders and are always visible. The same parameters are also visible in the respective folders 'Compressor', 'Fans', etc. (indicated also here to make the groupings clearer) in the password-protected Installer parameters menu.

PARA.	DESCRIPTION	U.M.	RANGE	DEFAULT
SEt	Temperature control SEtpoint	°C/°F	-58.0...302	0.0
COMPRESSOR (CPr)				
diF	Activation differential (absolute or relative). N.B.: diF cannot be equal to 0.	°C/°F	0 ... 30.0	2.0
HSE	Maximum value that can be assigned to the setpoint. NOTE: The two setpoints are interdependent: HSE cannot be less than LSE and vice versa.	°C/°F	LSE ... HdL	50.0
LSE	Minimum value that can be assigned to the setpoint. NOTE: The two setpoints are interdependent: LSE cannot be greater than HSE and vice versa.	°C/°F	LdL ... HSE	-50.0
OSP	Temperature value to be added algebraically to the Setpoint if reduced set enabled (Economy function). Enabling can be controlled by a key, function or specially configured digital input.	°C/°F	-30.0 ... 30.0	0.0
Cit	Minimum activation time of compressor before possible deactivation. If Cit = 0 not active.	min	0 ... 255	0
CAt	Maximum activation time of compressor before possible deactivation. If CAt = 0 not active.	min	0 ... 255	0
Ont	Controller switch-on time in the event of faulty probe. - if Ont = 1 and OFt = 0 , compressor stays on permanently (ON). - if Ont > 0 and OFt > 0 , compressor operates in Duty Cycle mode.	min	0 ... 255	10
OFt	Controller switch-off time in the event of faulty probe. - if OFt = 1 and Ont = 0 , compressor will always stay off (OFF). - if Ont > 0 and OFt > 0 , compressor operates in Duty Cycle mode.	min	0 ... 255	10
dOn	Switch-on delay. The parameter indicates that a protection is active on the general compressor relay actuations. At least the indicated time must elapse between the request and the actual activation of the compressor relay.	sec	0 ... 255	2
dOF	Delay time after power-off: the delay time indicated must elapse between deactivation of the compressor relay and the next power-on.	min	0 ... 255	0
dbi	Delay time between power-ons; the delay time indicated must elapse between two consecutive compressor power-ons.	min	0 ... 255	2
OdO	Delay in activating outputs after the instrument is switched on or after a power failure. 0 = not active	min	0 ... 255	0
DEFROST (dEF)				
dtY	Defrost mode 0 = electric defrost (defrost cycle OFF), or compressor not running during defrost. NOTE: electrical defrost + air defrost, in the case of fans connected in parallel to the defrost output relay. 1 = cycle inversion defrost (hot gas, or compressor on during defrost) 2 = "free" mode defrost (independent of compressor).	num	0 ... 2	0
dit	Interval between 2 defrost cycles Interval between the start of two consecutive defrost cycles. 0 = function disabled (defrost NEVER performed).	hours/mins/ secs	0 ... 255	6 hours
dCt	Defrost interval count mode 0 = compressor running time (DIGIFROST® method); defrost active ONLY when the compressor is on. NOTE: compressor running hours are counted separately from the evaporator probe (count active also when evaporator probe missing or faulty). 1 = appliance running hours; defrost count is always active when machine is on and starts at each power-up. 2 = compressor stopped Every time the compressor stops, a defrost cycle is performed according to parameter dtY; 3 = with RTC. defrost at specific times set by parameters dE1...dE8, F1...F8.	num	0 ... 3	1
dOH	Defrost cycle enabling delay from request Delay preceding start of first defrost after call.	min	0 ... 59	0
dEt	Defrost timeout Determines the maximum defrost time on Evaporator 1.	hours/mins/ secs	1 ... 255	30 min
dSt	Defrost end temperature Defrost 1 end temperature (determined by evaporator probe 1).	°C/°F	-302.0 ... 1472.0	6.0

PARA.	DESCRIPTION	U.M.	RANGE	DEFAULT
dPO	Defrost enabling request from power-on Determines whether or not the instrument must defrost at power-up (provided that the temperature measured at the evaporator will allow defrost). n = no, does not start defrosting at power-on; y = yes, starts defrost at power-on	flag	n/y	n
FANS (FAn)				
FSt	Fans lockout temperature; if the value read is greater than FSt, the fans will be stopped. The value can be positive or negative	°C/°F	-58.0...302	0.0
FAd	Fans activation differential.	°C/°F	0.1 ... 25.0	0.1
Fdt	Fans activation delay after a defrost cycle.	min	0 ... 250	0
dt	dripping time.	min	0 ... 250	0
dFd	Operating mode of evaporator fans during defrost. OFF (0) = Fans Off; On (1) = Fans On	flag	OFF/On	On
FCO	Evaporator fans operating mode. The status of the fans will be: A compressor ON fans thermoregulated, A compressor OFF depends on FCO FCO=0 , fans OFF FCO=1-2 , fans thermoregulated FCO=3-4 , fans in duty cycle Dutycycle : controlled by way of parameters "FOn" and "FOF".	num	0 ... 4	1
ALARMS (ALr)				
AFd	Alarms cut-in differential.	°C/°F	0.1 ... 25.0	1.0
HAL	Probe 1 maximum alarm. Temperature value (intended either as distance from setpoint or as an absolute value based on Att) above which the probe will trigger activation of the alarm signal.	°C/°F	LA1...302	5.0
LAL	Probe 1 minimum alarm Temperature value (intended as distance from setpoint or as an absolute value based on Att) beneath which the probe will trigger activation of the alarm signal.	°C/°F	-58.0...HA1	-5.0
PAO	Alarm override time after device is switched on following a power failure. This parameter refers to high/low temperature alarms LAL and HAL only	hours	0 ... 10	3
dAO	Temperature alarm override time after defrost.	min	0 ... 250	60
OAO	Alarm indication delay (high and low temperature) following deactivation of digital input (port closed).	hours	0 ... 10	1
tAO	Delay preceding indication of temperature alarm. This parameter refers to high/low temperature alarms LAL and HAL only	min	0 ... 250	0
DISPLAY parameters (diS)				
LOC	LOCK. Setpoint edit lock. The parameter programming menu can still be accessed, and the settings changed, which means also that the status of this parameter can be changed so as to unlock the keypad. n (0) = no y (1) = yes.	flag	n/y	n
PA1	PAssword 1. When enabled (PA1 ≠ 0) it is the access key for the level 1 parameters (User).	num	0 ... 250	0
ndt	Display values with decimal point. n (0) = no (integers only) y (1) = yes (display with decimal point).	flag	n/y	y
CA1	Calibration of probe Pb1. Positive or negative temperature value added to the value read by Pb1. This sum is used for both temperature display and temperature regulation purposes.	°C/°F	-30.0...30.0	0.0
CA2	Calibration of probe Pb2. Positive or negative temperature value added to the value read by Pb2. This sum is used for both temperature display and temperature regulation purposes.	°C/°F	-30.0...30.0	0.0
ddl	Display mode during defrost. 0 = displays the temperature read by probe 1 = locks the reading at the temperature value registering via the probe when the defrost cycle starts and until the next time the S _{Et} is reached. 2 = displays the label dEF during defrosting and until the next time the S _{Et} is reached (or until L _{dd} has elapsed).	num	0/1/2	1
CONFIGURATION (CnF) If one or more parameters present in the folder are changed, the controller MUST be switched off and switched on again.				
H00	Selection of type of probe used (Pb1 ... Pb3). (0) = PTC (1) = NTC	num	0/1 (PTC/NTC)	1 (NTC)

PARA.	DESCRIPTION	U.M.	RANGE	DEFAULT
H23	Configuration of digital output 3 (OUT 3).	num	0 ... 13	3
	0 = disabled 1 = compressor 2 = defrost 1 3 = Evaporator fans 4 = alarm 5 = AUX 6 = Stand-by 7 = light 8 = Buzzer output 9 = defrost 2 10 = compressor 2 11 = frame heater 12 = Condenser fans 13 = Compressor Pump Down			
H42	Evaporator probe (Pb2) present n (0) = not present y (1) = present	num	n/y	y
rEL	Firmware version release (e.g. 1,2,...). Read only. See Technical Support.	/	/	/
tAb	Map code. Read only. See Technical Support.	/	/	/
COPY CARD parameters (FPr)				
UL	Upload. Transfer of programming parameters from instrument to Copy Card	/	/	/
dL	Download. Transfer of programming parameters from Copy Card to instrument	/	/	/
Fr	Formatting. To erase data on Copy Card. IMPORTANT: If parameter "Fr" is used, the data entered will be permanently lost. This operation cannot be reversed.	/	/	/

THE INSTRUMENT IS USED TO EDIT OTHER PARAMETERS PRESENT IN THE INSTALLER LEVEL (inS)

How to edit the installer level parameters

Procedure applies only to more advanced applications. In this case the parameters are arranged in folders (Compressor / Defrost / Fans etc)

- 1) Press and hold the SET key for 3 seconds until the display shows PAR / USr
- 2) Use UP & DOWN to select the parameter section **inS**
- 3) Press and release the SET key once more. The display will show the first folder
- 4) Press and release the SET key once more. The upper display will show the first parameter in the folder, the lower display will indicate the current parameter value
- 5) Using the UP & DOWN keys, find the parameter that you wish to modify

The procedure proceeds in a similar manner to that described for the User parameters (points 4-7)

OPERATION IN DEFAULT CONFIGURATION

The instrument is configured for negative cold. For positive cold, disable the evaporator probe Pb2 (set H42=n) and set relay OUT3 (parameter H23=6) to prevent continuous ventilation.

COMPRESSOR

The compressor is active if the cold room temperature detected by Pb1 exceeds the value of SEt + differential diF. The compressor stops if the cold room temperature detected by Pb1 falls below the SEt value. The instrument includes compressor on/off protection*

DEFROST

Defrost is by means of electric heaters (parameter dty = 0) and the time counter is always active with the instrument switched on (dCt=1).

Manual defrost

Manual defrost is activated by pressing and holding the ESC key (A).

If conditions for defrosting are not present, (e.g. the evaporator probe temperature is higher than the defrost end temperature) or the parameter OdO≠0, the display will blink three times to indicate that the operation will not be performed.

Default Defrost settings

dit = 6 hours. interval between 2 defrost cycles

dSt = 6.0°C. defrosting end temperature set by Pb2.

The Defrost cycle may terminate due to timeout based on the parameter dEt (default 30 min).

EVAPORATOR FANS

Relay OUT3 is configured as fans relay and is activated in the required cases, according to delays and parameter settings*

Default fan settings

dt = 0 min. dripping time

dFd = Y. Fans off during defrosting.

LIGHT (EWRC 500 NT)

The light is activated by pressing and holding the LIGHT key (F).

Since digital input D.I. 1 is configured as door switch, relay OUT4 (light) is activated when the door is opened. The light also switches on with the instrument in stand-by*.

ALARM RELAY (EWRC 500 NT)

Relay OUT5 is configured as alarm relay and is activated in the case of alarms, according to delays and parameter settings. *FOR MORE INFORMATION READ the manual, code **9MA10258**

SUPERVISION

EWRC 300/500 NT can be connected to:

- **TelevisSystem** or external system remote control system via Modbus protocol
- **DeviceManager** fast parameter setting software

The connection can be made by direct RS-485 connection using the optional RS485/TTL plug-in module (not included). See Electrical Connections.

*FOR MORE INFORMATION READ the manual, code **9MA10258**

TECHNICAL SUPPORT

Please have the following information available when contacting Eliwell Technical Support:

- **IdF firmware version (e.g. 554)**
- **rEL firmware version release (e.g. 1,2,...)**
- **tAb map code**
- **rC instrument model (e.g. 300 or 500)**

To obtain this information:

- Press and release the DOWN / INFO key
- Press and release the DOWN key once more to display other information about the instrument.
- Press the ESC key to return to the normal display.

ALARMS AND TROUBLESHOOTING

How to display the alarms

1) Press and release the UP key. The upper display will always show the label ALr. The lower display will show:

- nOnE if no alarms active
- SYS to indicate system alarms - see Alarms Table
- HACCP to indicate HACCP alarms - see HACCP alarms

2) Using the UP & DOWN keys, find the type of alarm that you want to check

System alarms

The upper display will show the label ALr, the lower display will indicate the alarm code - see Alarms Table

- Using the UP & DOWN key, scroll the other alarms
- Press the ESC key to return to the previous alarm code, press the ESC key several times (or keep it pressed) to return to the normal display

HACCP ALARMS • AVAILABLE ONLY FOR HACCP MODELS

The instrument logs high and low temperature alarms for the cold room probe, as well as any power failures. The alarm types and the duration and start time of the alarm itself will be displayed in the alarms folder ALr. It is possible to disable the recording of alarms and/or resetting of HACCP alarms. See Functions Menu.

FOR MORE INFORMATION READ the manual, code **9MA10258**

ALARMS TABLE

This section lists alarms associated with the default configuration of the instrument.
For a description of alarms relating to custom configurations, refer to the user manual or contact Eliwell Technical Support.

Label	Cause	Effects	Problem solving
E1*	Pb1 room probe faulty • Measured values are outside operating range • Probe faulty/short-circuited/open	• Label E1 displayed • Disabling of maximum and minimum alarm regulator • Compressor operation based on parameters "Ont" and "Oft" if set for duty cycle.	• Check probe type NTC/PTC (see H00) • Check probe wiring. • Replace probe
E2*	Pb2 defrost probe faulty • Measured values are outside operating range • Probe faulty/short-circuited/open	• Label E2 displayed • The Defrost cycle will end due to time-out (Parameter "dEt")	• Check probe type NTC/PTC (see H00) • Check probe wiring. • Replace probe
LA1	Pb1 LOW temperature alarm • Value read by Pb1 < LAL after time of tAO.	• Recording of label LA1 in folder ALr • No effect on regulation.	• Wait for the temperature value read by Pb1 to come back above LAL+AFd
HA1	Pb1 HIGH temperature alarm • value read by probe Pb1 > HAL after time of "tAO".	• Recording of label HA1 in folder ALr • No effect on regulation.	• Wait until temperature value read by Pb1 returns below HAL-AFd.
Ad2	End of defrost cycle due to time-out rather than due to defrost end temperature being read by the defrost probe	• Recording of label Ad2 in folder ALr	• Wait for the next defrost cycle for automatic return
OPd	• Activation of digital input (set as door switch) See para. H11/H12 • Depends on delay set by parameter td0	• Recording of label OPd in folder ALr • Regulator locked (see para. dOA/PEA)	• Close door • Depends on delay set by parameter OAO
E10**	**Models with clock only Clock alarm clock faulty or battery low	Functions associated with clock not present	Contact Eliwell Technical Support

ALL ALARMS

- Alarm icon permanently alight
- Buzzer (if present) and alarm relay (OUT5) activated, except Ad2
- Press any key to silence the alarm. The LED changes from a steady light to a blinking light. NOTE: the buzzer is deactivated while the alarm relay remains active

*E1 - E2: If simultaneous they will be shown alternately on the display at a frequency of 2 seconds

WARNINGS

Important! Make sure the appliance is switched off before working on the electrical connections.

• **Probe and digital inputs, OUT5 relay: screw-on terminals pitch 5.01:** electric cables with max. cross-section 2.5 mm² (only one wire per terminal for power connections).

• **Power supply and relay OUT1..OUT4: screw-on terminals pitch 7.62:** electric cables with max. cross-section of 4 mm² (only one wire per terminal for power connections).

For the capacity of the terminals, see the label on the instrument. Outputs on OUT1-4 relay max. capacity 18A.

Do not exceed the maximum permitted current; for higher loads, use a contactor with sufficient power capacity. Make sure that power supply is of the correct voltage for the instrument.

Probes have no connection polarity and can be extended using a normal two-core cable (note that extension of the probe leads influences the instrument's electromagnetic compatibility - EMC and measurement class: take great care with the wiring). Probe cables, power supply cables and the TTL serial cables should be routed separately from power cables.

TECHNICAL SPECIFICATIONS (EN 60730-2-9)

DESCRIPTION	
Front panel	IP65
Classification	electronic automatic control device (not safety) device for stand-alone installation
Installation	wall mounted (distance between holes A-B 116 mm; holes C-D 87 mm holes A-C 235 mm See Mechanical Installation paragraph Hinges are available for mounting on special compartments for opening the cover both right and left. Screw on the respective anchoring screws taking care that the hinges are fitted well and lie flush so that they do not interfere with the compression of the seal
Type of action	1.B
Pollution class	2
Material class	IIIa
Over voltage category	II
Nominal pulse voltage	2500V~
Operating temperature	-5°C...+50°C
Power supply	230V~ ± 10% 50/60Hz
Power consumption	14W max
Digital outputs (relay)	refer to the label on the device
Fire resistance category	D
Software class	A
Connection	device on external flexible cable, Y type connection
Ball test temperature	100°C

FURTHER INFORMATION

DESCRIPTION			
Container	Bayblend FR 3010		
Dimensions	front panel 213x318mm, depth 102mm		
Connections	screw-on terminals (see wiring diagram) with internal housing for magnetothermal switch, remote control switch, contactor, etc. on DIN rail IMPORTANT: do not exceed ampere limits		
Storage temperature	-20°C...+85°C		
Operating humidity	10...90% RH non-condensing		
Storage humidity			
Display range	-50...110 (NTC) / -55...150°C (PTC) no decimal point, on 2 displays: (upper display) 3 digit + sign/ (lower display) 4 digit		
Analogue Inputs	3 NTC inputs PTC configurable by parameter H00		
Digital Inputs	2 digital inputs no voltage configurable from parameter H11/H12		
Relay outputs	<table border="0"> <tr> <td style="vertical-align: top;"> <p>Model EWRC 300 NT</p> <ul style="list-style-type: none"> • OUT1 output SPST 2HP 12(12)A 250V~ • OUT2 output SPST 1HP 8(8)A 250V~ • OUT3 output SPST 1/2HP 8(4)A 250V~ <p>common-line max 18A</p> </td> <td style="vertical-align: top;"> <p>Model EWRC 500 NT</p> <ul style="list-style-type: none"> • OUT1 output SPST 2HP 12(12)A 250V~ • OUT2 output SPST 1HP 8(8)A 250V~ • OUT3 output SPST 1/2HP 8(4)A 250V~ • OUT4 output SPST 1/2HP 8(4)A 250V~ • OUT5 output SPDT 1HP 8(8)A 250V~ <p>common-line max 18A</p> </td> </tr> </table>	<p>Model EWRC 300 NT</p> <ul style="list-style-type: none"> • OUT1 output SPST 2HP 12(12)A 250V~ • OUT2 output SPST 1HP 8(8)A 250V~ • OUT3 output SPST 1/2HP 8(4)A 250V~ <p>common-line max 18A</p>	<p>Model EWRC 500 NT</p> <ul style="list-style-type: none"> • OUT1 output SPST 2HP 12(12)A 250V~ • OUT2 output SPST 1HP 8(8)A 250V~ • OUT3 output SPST 1/2HP 8(4)A 250V~ • OUT4 output SPST 1/2HP 8(4)A 250V~ • OUT5 output SPDT 1HP 8(8)A 250V~ <p>common-line max 18A</p>
<p>Model EWRC 300 NT</p> <ul style="list-style-type: none"> • OUT1 output SPST 2HP 12(12)A 250V~ • OUT2 output SPST 1HP 8(8)A 250V~ • OUT3 output SPST 1/2HP 8(4)A 250V~ <p>common-line max 18A</p>	<p>Model EWRC 500 NT</p> <ul style="list-style-type: none"> • OUT1 output SPST 2HP 12(12)A 250V~ • OUT2 output SPST 1HP 8(8)A 250V~ • OUT3 output SPST 1/2HP 8(4)A 250V~ • OUT4 output SPST 1/2HP 8(4)A 250V~ • OUT5 output SPDT 1HP 8(8)A 250V~ <p>common-line max 18A</p>		
Buzzer	only on models where this is provided		
Serial ports	<ul style="list-style-type: none"> • 1 TTL port for connection to Unicard / Copy Card / MFK • 1 TTL port for connection to TelevisSystem • 1 RS-485 serial port for connection to TelevisSystem (use with optional plug-in module) 		
Accuracy	better than 0.5% of end of scale + 1 digit		
Resolution	1 or 0.1 °C		
RTC battery life	In a power failure, the clock battery will last 4 days.		

Food safety

The device complies with standard EN13485 as follows:

- Suitable for storage.
- Application: air.
- Climate range A.
- measurement class 1 in the -25°C and 15°C (exclusively using Eliwell probes)

CONDITIONS OF USE - Permitted use

For safety reasons, the device must be installed and used in accordance with the instructions provided. In particular, parts carrying dangerous voltages must not be accessible under normal conditions.

The device must be adequately protected from water and dust with regard to the application, and must only be accessible using tools (with the exception of the front panel).

The device is suitable for use as a stand-alone unit and has been tested for safety aspects in accordance with harmonised European reference standards.

Prohibited use

Any use other than that expressly permitted is prohibited.

The relays provided are of a functional type and can be subject to failure: any protection devices required by product standards, or suggested by common sense for obvious safety requirements, must be installed externally to the controller.

RESPONSIBILITY AND RESIDUAL RISKS

Eliwell Controls srl declines any liability for damage due to:

- installation/uses other than those expressly specified and, in particular, failure to comply with the safety requirements of established standards and/or instructions specified in this document;
- use on panels that do not provide adequate protection against electric shock, water or dust, when mounted;
- Use on panels allowing access to dangerous parts without having to use tools.
- Tampering with and/or modification of the product.
- Installation/use on panels which are not compliant with current standards and regulations.

DISCLAIMER

This document is the exclusive property of Eliwell and cannot be reproduced or circulated unless expressly authorised by Eliwell. All possible care has been taken to ensure the accuracy of this document; nevertheless, Eliwell Controls srl cannot accept liability for any damage resulting from its use. The same applies to any person or company involved in the creation and preparation of this document. Eliwell reserves the right to make aesthetic or functional changes at any time without notice.

DISPOSAL



The equipment (or product) must be subjected to separate waste collection in compliance with the local legislation on waste disposal.

CUT OUT

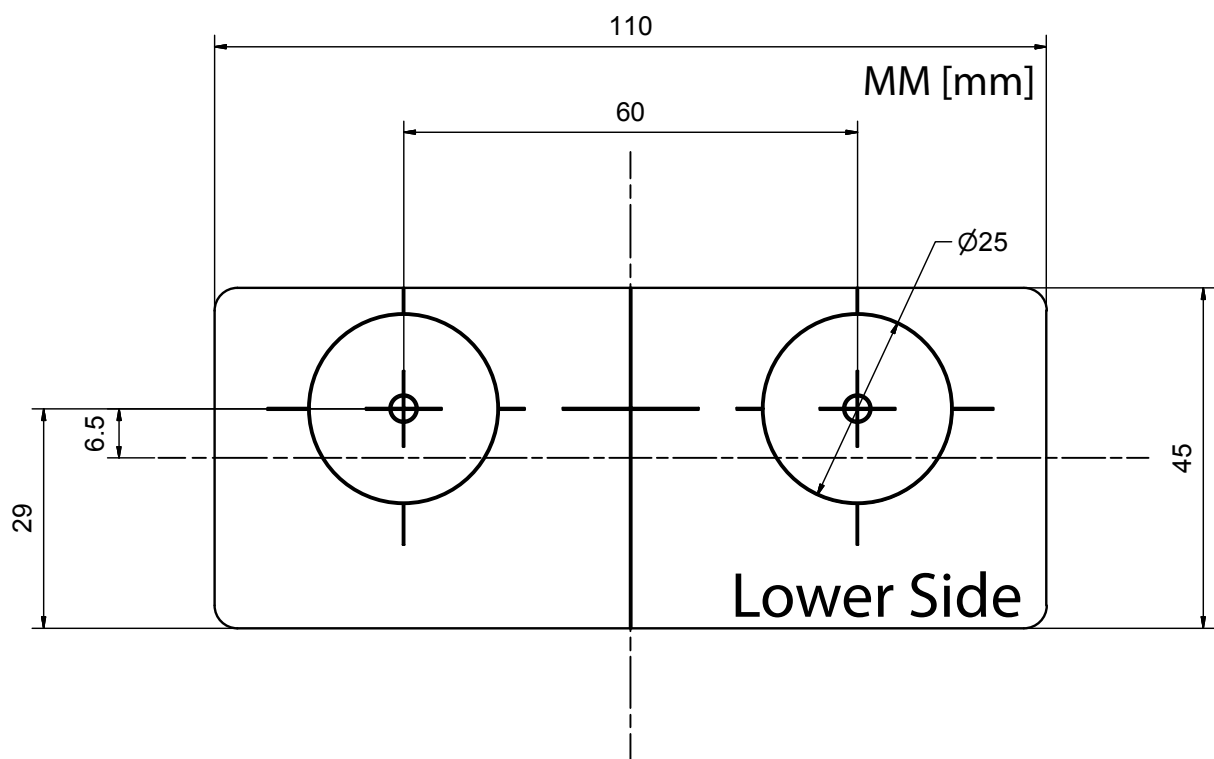

Eliwell Controls s.r.l.

Via dell'Industria, 15 • Z.I. Paludi
32010 Pieve d'Alpago (BL) ITALY
T +39 0437 986 111

www.eliwell.com

Technical Customer Support

T +39 0437 986 300
E techsuppeliwell@schneider-electric.com

Sales

T +39 0437 986 100 (Italy)
T+39 0437 986 200 (other countries)
E saleseliwell@schneider-electric.com

