

EVBOX1

Front mounted electrical boards for cold rooms with single-phase compressor





Important

Read this document thoroughly before installation and before use of the device and follow all recommendations; keep this document with the device for future consultation.

Only use the device in the way described in this document; do not use the same as a safety device.



Disposal

The device must be disposed of in compliance with local standards regarding the collection of electric and electronic equipment.

Index

1	INTRODUCTION.....4	6.10	Displaying some instant values joined to the electronic expansion valve (only in models EVB1246 and EVB1256).....30
1.1	Introduction.....4	6.11	Keyboard locking/unlocking.....31
1.2	Summary table of available models, their main characteristics and purchase codes.....5	6.12	Silencing the buzzer.....32
2	DESCRIPTION.....9	7	OPERATION WITH LOW OR HIGH RELATIVE HUMIDITY PERCENTAGES (ONLY IF THE F0 PARAMETER IS SET TO 5).....33
2.1	Outward appearance description.....9	7.1	Preliminary notes.....33
2.2	Interior description.....11	7.2	Manual activation of the low and high relative humidity percentages operating mode.....33
3	DIMENSIONS AND INSTALLATION.....14	7.3	Learning the current operating mode.....33
3.1	Dimensions.....14	8	"ENERGY SAVING" FUNCTION.....34
3.2	Installation.....14	8.1	Preliminary notes.....34
3.3	Installation warnings.....14	9	"CPT" FUNCTION (CALCULATED PRODUCT TEMPERATURE).....34
4	ELECTRIC CONNECTION.....16	9.1	Preliminary notes.....34
4.1	Preliminary notes.....16	10	"HACCP" FUNCTION.....34
4.2	Electric connection for models EVB1204 and EVB1214.....17	10.1	Preliminary notes.....34
4.3	Electric connection for models EVB1206 and EVB1216.....18	10.2	Display of HACCP alarm information.....35
4.4	Electric connection for models EVB1226 and EVB1236.....19	10.3	Cancelling the HACCP alarm list.....36
4.5	Electric connection for models EVB1246 and EVB1256.....20	11	DATA LOGGING EXTENSION FOR EN 12830 STANDARD COMPLIANCE.....37
4.6	Electric connection for models with direct loads connection (example for EVB1216N9XXC).....21	11.1	Preliminary information.....37
4.7	Electric connection for models with data logging extension for EN 12830 standard compliance (example for EVB1214N9XLC).....22	11.2	"HACCP" writing mode.....37
4.8	Electric connection for models with magneto-thermal switch or differential magneto-thermal circuit breaker (example for EVB1256N9D).....23	11.3	"Service" writing mode.....38
4.9	Insertion of the RS-485 MODBUS port termination resistor.....24	11.4	Nomenclature of files.....39
4.10	Connection of the RS-485 network cable screen to GND.....24	11.5	Showing the errors about the data logging extension.....39
4.11	Warnings for the electric connection.....24	12	COMPRESSOR OPERATING HOURS COUNT.....40
5	FIRST USE.....25	12.1	Preliminary notes.....40
5.1	First use.....25	12.2	Display of Compressor Operation Hours.....40
6	USER INTERFACE.....27	12.3	Cancelling the compressor operation hours.....41
6.1	Preliminary notes.....27	13	SETTINGS.....42
6.2	Device switch-on/off in manual mode.....27	13.1	Setting the date, time and day of the week (only in the models with clock).....42
6.3	The display.....27	13.2	Setting the working set point.....43
6.4	Displaying the magnitude detected by an analogue input.....27	13.3	Setting the configuration parameters.....43
6.5	"Rapid cooling" function enabling/disabling.....29	13.4	Restoring the Manufacturer's settings.....44
6.6	Defrosting manual activation.....29	13.5	List of configuration parameters.....45
6.7	Turning on/off of room lights manually (only if the parameter u1 and/or parameter u11 is set at 0).....29	14	WARNING LIGHTS AND DIRECTIONS.....82
6.8	Turning the demister heating elements on/off manually (only if the parameter u1 and/or parameter u11 is set at 1).....30	14.1	Signals.....82
6.9	Turning on/off of the auxiliary output manually (only if the parameter u1 and/or parameter u11 is set at 2).....30	14.2	Signal Descriptions/Explanations.....84
		15	ALARMS.....85
		15.1	Alarms.....85
		16	ERRORS.....88
		16.1	Errors.....88
		17	ACCESSORIES.....91
		17.1	Non opto-isolated RS-485/USB serial interface EVIF20SUXI.....91
		17.2	Data recorder EVUSBREC01.....91
		17.3	USB cover for panel installation 0812000002.....91
		17.4	0810500018/0810500020 connection cable.....92
		18	TECHNICAL DATA.....93
		18.1	Technical data.....93

1 INTRODUCTION

1.1 Introduction

EVBOX1 is a line of front mounted electrical boards for the management of cold rooms with single-phase compressor.

The user interface comprises a large custom display (with decimal point and function icons), six keys, and has a guaranteed IP65 protection grade front part.

The boards are equipped with two 30A res. @ 250 VAC relays for the direct control of high power compressors and defrosting elements, with no need for remote control switches.

They can operate in conditions of both low and high relative humidity percentages, have an adaptive management of the defrost function, and can implement energy-saving strategies.

Some models are also equipped with a magneto-thermal switch or differential magneto-thermal circuit breaker, a clock (to save the HACCP alarms), management of defrosting elements and have an integrated driver for unipolar stepper electronic expansion valves; some more of a data logging extension (on SD card) for EN 12830 standard compliance.

The unit is designed to be wall mounted, with bolts and fastening screws.

1.2 Summary table of available models, their main characteristics and purchase codes

The following table contains a description of the available models.

Available models	EVB1204	EVB1214	EVB1206	EVB1216	EVB1226	EVB1236	EVB1246	EVB1256
------------------	---------	---------	---------	---------	---------	---------	---------	---------

The following table shows the main characteristics of the devices.

	EVB1204	EVB1214	EVB1206	EVB1216	EVB1226	EVB1236	EVB1246	EVB1256
Power supply								
115... 230 VAC	•	•	•	•	•	•	•	•
Analogue inputs								
room temperature (PTC/NTC/Pt 1000)	•	•	•	•	•	•	•	•
evaporator temperature (PTC/NTC/Pt 1000)	•	•	•	•	•	•	•	•
auxiliary temperature (PTC/NTC/Pt 1000) (1)	•	•	•	•	•	•	•	•
auxiliary temperature 2 (NTC/Pt 1000) (2)		•		•				•
auxiliary temperature 3 (NTC/Pt 1000) (2)		•		•				•
evaporation pressure (4-20 mA)							•	•
evaporation temperature (PTC/NTC/Pt 1000)							•	•
Digital inputs (for NA/NC contact)								
door micro switch	•	•	•	•	•	•	•	•
multifunction	•	•	•	•	•	•	•	•
multifunction 2	•	•	•	•	•	•	•	•
Digital inputs (electromechanical relays; A res. @ 250 VAC)								
compressor	30 A	30 A	30 A	30 A	30 A	30 A	30 A	30 A
defrosting	16 A	16 A	16 A	16 A	16 A	16 A	16 A	16 A
evaporator fan	30 A	30 A	30 A	30 A	30 A	30 A	30 A	30 A

room light			16 A	16 A	16 A	16 A	16 A	16 A
load 4 (default to room light) (3)	8 A	8 A						
load 5 (default to condenser fan) (4)			8 A	8 A	8 A	8 A	8 A	8 A
load 6 (default to alarm) (4)			8 A	8 A	8 A	8 A	8 A	8 A
Communication ports								
RS-485 MODBUS for other EVCO products	•	•	•	•	•	•	•	•
Other characteristics								
clock		•		•		•		•
alarm buzzer	•	•	•	•	•	•	•	•
three-phase defrost elements management					•	•		
data logging extension for EN 12830 standard compliance		•		•				•
integrated driver for unipolar stepper electronic expansion valves.							•	•
operation at low and high relative humidity percentages	•	•	•	•	•	•	•	•
overheated condenser alarm management	•	•	•	•	•	•	•	•
defrosting adaptive management	•	•	•	•	•	•	•	•
"HACCP" function		•		•		•		•
"energy saving" function	•	•	•	•	•	•	•	•
"rapid cooling" function	•	•	•	•	•	•	•	•

Notes

- (1) can be set through a configuration parameter to condenser temperature, critical temperature, evaporator 2 temperature or CPT temperature parameter
- (2) only available in the models with data logging for EN 12830 standard compliance
- (3) can be set through a configuration parameter to room light, demister heating elements, auxiliary, alarms, door resistors, neutral area operation resistors, condenser fan, compressor 2, defrosting 2 evaporator fan 2, pump down valve, on/stand-by or man in cold room
- (4) can be set through a configuration parameter to demister heating elements, auxiliary, alarms, door resistors, neutral area operation resistors, condenser fan, compressor 2, defrosting 2 evaporator fan 2, pump down valve, on/stand-by or man in cold room.

Available options

In some models, there is a magneto-thermal switch or differential magneto-thermal circuit breaker.

Check that the switch is available for the device; contact the EVCO distribution network.

For additional information, please read chapter "TECHNICAL DATA",

The following tables show the purchase codes.

Switchboards for single-phase cold rooms (3)	EVB1204N9	EVB1206N9	EVB1206N9M (1)	EVB1206N9D (2)	EVB1216N9	EVB1216N9M (1)	EVB1216N9D (2)	EVB1246N9D (2)	EVB1256N9D (2)
---	-----------	-----------	----------------	----------------	-----------	----------------	----------------	----------------	----------------

Notes

- (1) with magneto-thermal switch
- (2) with differential magneto-thermal circuit breaker
- (3) also available in version with direct loads connection (add "XXC" after "9" or "XC" after "M" and "D" to the purchase code).

Switchboards for single-phase cold rooms with three-phase defrost heater management	EVB1226N9XXC	EVB1236N9XXC
--	--------------	--------------

Switchboards for single-phase cold rooms with data logging extension for EN 12830 standard compliance (2)	EVB1214N9XLC	EVB1216N9XLC	EVB1216N9MLC (1)	EVB1256N9MLC (1)
--	--------------	--------------	------------------	------------------

Notes

- (1) with magneto-thermal switch
- (2) also available with 2 temperature probes included (NTC sensor, cable 3 m long); **SD card not included.**

2 DESCRIPTION

2.1 Outward appearance description

The following drawing shows the outward appearance of the devices.

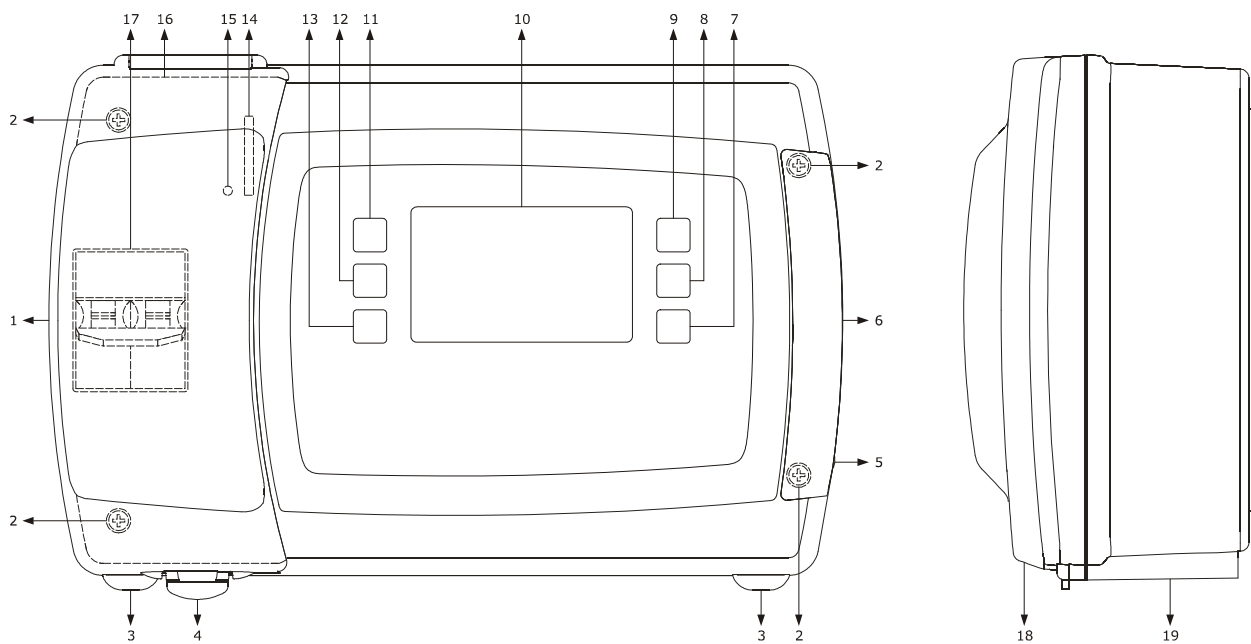

The following table shows the meaning of the parts of the front of the devices

PART	MEANING
1	access door to the magneto-thermal switch or differential magneto-thermal circuit breaker
2	screws fastening the front shell to the back shell
3	tab fastening the front shell to the back shell
4	handle of the access door to the magneto-thermal switch or differential magneto-thermal circuit breaker
5	handle to remove the cover of the screws fastening the front shell to the back shell
6	cover of the screws fastening the front shell to the back shell
7	on/off key, hereinafter also "ON/STAND-BY" key
8	manual defrosting key, hereinafter also "DEFROSTING" key
9	auxiliary functions key, hereinafter also "AUXILIARY" key
10	display
11	increase key, hereinafter also "UP" key
12	settings key, hereinafter also "SET" key

13	decrease key, hereinafter also "DOWN" key
14	slot for SD card
15	SD card status LED
16	seal
17	if present, magneto-thermal switch or differential magneto-thermal circuit breaker
18	front shell
19	back shell

For additional information, please refer to the following chapters.

2.2 Interior description

To access the interior of the devices, proceed as follows (numbers in parentheses refer to the part number shown in the tables in paragraph 2.1 "Outward appearance description"):

1. Open the access door of the magneto-thermal switch or differential magneto-thermal circuit breaker (1) using the relevant handle (4) and loosen the two screws fastening the front shell to the back shell (2) with a screwdriver.
2. Remove the cover of the two screws fastening the front shell to the back shell (6) using the relevant handle (5) and loosen the two screws fastening the front shell to the back shell (2) with a screwdriver.
3. Lift the front shell (18) using the assembly tabs fastening the front shell to the back shell (3) as a pivot.

The following drawing shows the inner appearance of the devices.

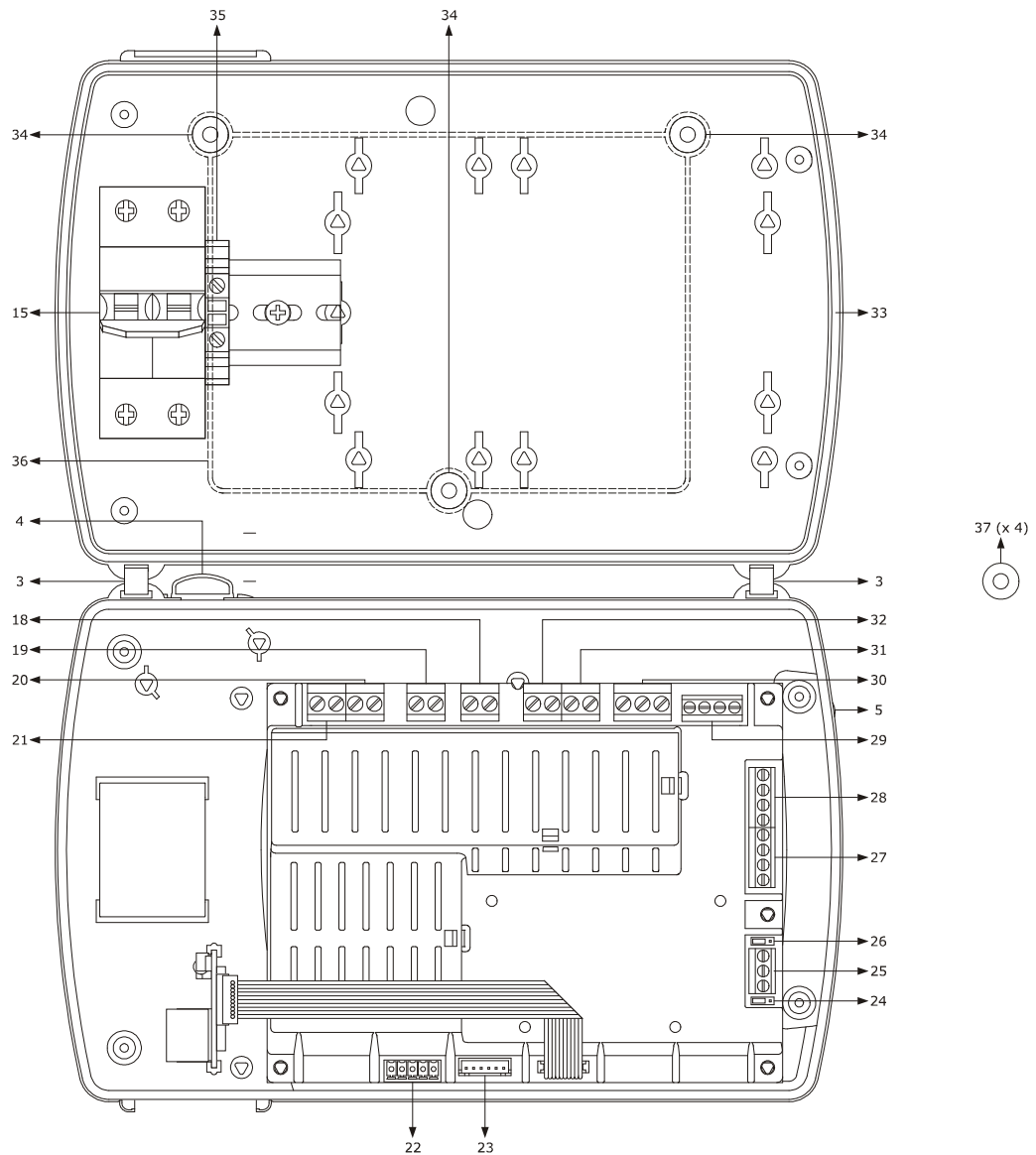

The following table shows the meaning of the parts inside the devices

PART	MEANING
3	tab fastening the front shell to the back shell
4	handle of the access door to the magneto-thermal switch or differential magneto-thermal circuit breaker
5	handle to remove the cover of the screws fastening the front shell to the back shell
15	if present, magneto-thermal switch or differential magneto-thermal circuit breaker
18	K3 digital output (evaporator fan)
19	K2 digital output (defrosting)
20	K1 digital output (compressor)
21	device power supply
22	if present, driver for unipolar stepper electronic expansion valves connected to a removable male only screw terminal board
23	if present, driver for unipolar stepper electronic expansion valves connected with male only JST connector
24	BUS RS-485 polarisation jumper
25	RS-485 MODBUS port
26	RS-485 MODBUS port termination resistor insertion jumper
27	digital inputs (micro port, multifunction 1 and multifunction 2)
28	analogue inputs 1 and 2 (room temperature and evaporator temperature) and analogue input 3 (can be set through a configuration parameter to condenser temperature, critical temperature, evaporator 2 temperature or CPT temperature)
29	if present, analogue inputs 4 and 5 (evaporation temperature and vapour pressure)
30	<p>in the EVB1204 and EVB1214 models, K4 digital output (can be set through a configuration parameter to room light, demister heating elements, auxiliary, alarms, door resistors, neutral area operation resistors, condenser fan, compressor 2, defrosting 2, evaporator fan 2, pump down valve, on/stand-by or man in cold room; manufacturer default is room light).</p> <p>in the remaining models, K6 digital output (can be set through a configuration parameter to demister heating elements, auxiliary, alarms, door resistors, neutral area operation resistors, condenser fan, compressor 2, defrosting 2, evaporator fan 2, pump down valve, on/stand-by or man in cold room; manufacturer default is alarm).</p>

31	if present, K5 digital output (can be set through a configuration parameter to demister heating elements, auxiliary, alarms, door resistors, neutral area operation resistors, condenser fan, compressor 2, defrosting 2, evaporator fan 2, pump down valve, on/stand-by or man in cold room; manufacturer default is condenser fan).
32	if present, digital output 4 (room light)
33	seal
34	drilling lead for wall installation
35	ground terminal
36	raised profile
37	seal

For additional information, please refer to the following chapters.

3 DIMENSIONS AND INSTALLATION

3.1 Dimensions

The following drawing shows the measurements of the devices, in mm (in).

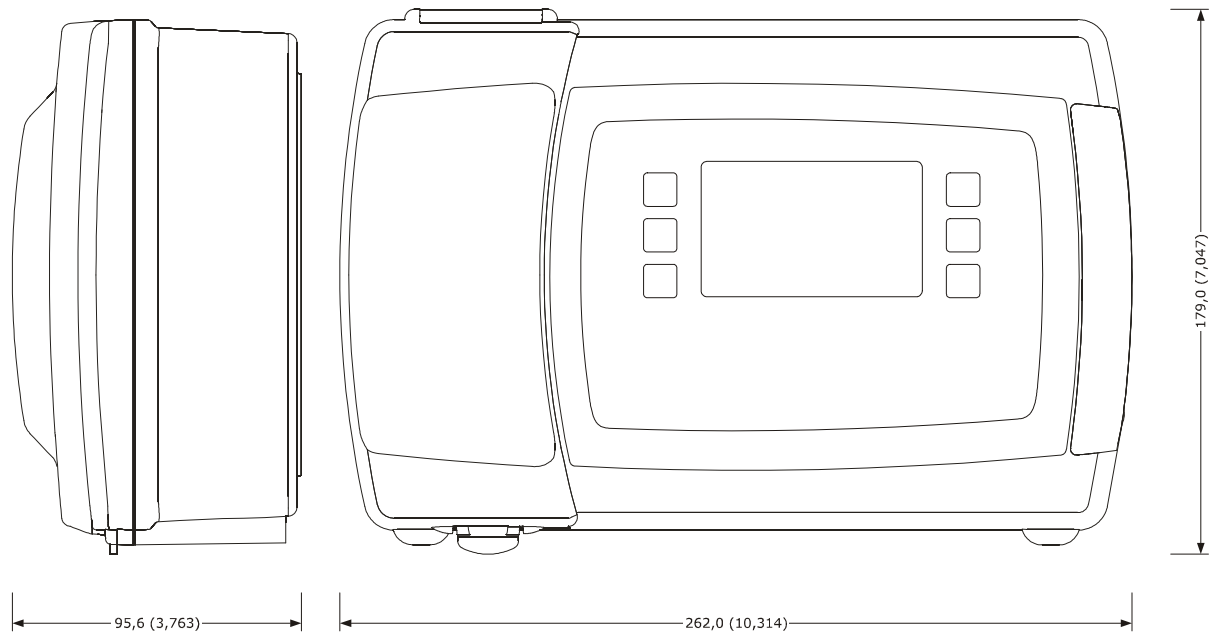

3.2 Installation

The unit is designed to be wall mounted, with bolts and fastening screws (not supplied).

To install the devices, proceed as follows (numbers in parentheses refer to the part number shown in the tables in chapter 2 "DESCRIPTION"):

1. Open the access door of the magneto-thermal switch or differential magneto-thermal circuit breaker (1) using the relevant handle (4) and loosen the two screws fastening the front shell to the back shell (2) with a screwdriver.
2. remove the cover of the two screws fastening the front shell to the back shell (6) using the relevant handle (5) and loosen the two screws fastening the front shell to the back shell (2) with a screwdriver.
3. Lift the front shell (18) using the assembly tabs fastening the front shell to the back shell (3) as a pivot.
4. Drill a hole with a diameter of 5.0 mm (0.196 in) in each of the three drilling leads for wall installation (34).
5. Drill three 6.0 mm (0.236 in) holes in the wall where the device is to be installed, using the three previously perforated drilling leads (34) as template.
6. Insert three bolts in the three holes drilled into the wall.
7. Insert three seals (37) in three fastening screws.
- 8.1 If the connection wires are to be threaded from the top or the bottom, drill a hole in a flat surface of the back shell (19), whose dimensions are adequate for a cable tray (not supplied; the cable tray dimensions must be appropriate to the number of cables to be laid) and assemble the cable tray.
- 8.2 If the connection cables are to be installed from the back, drill a hole with dimensions appropriate to the number of cables to be laid in the raised profile (36) on the back wall of the back shell (19) and apply some silicone on the whole profile.
9. Fasten the back shell (19) with the three screws and the seals (37) previously inserted in the screws.
10. make the necessary electric connections; please refer to chapter "ELECTRIC CONNECTION".
11. Place the front shell (18) on the back shell (19) using the assembly tabs fastening the front shell to the back shell (3) as a pivot.
12. Tighten the four screws fastening the front shell to the back shell (2) with a screwdriver, put the fastening screws cover (6) back on and close the access door to the magneto-thermal switch or differential magneto-thermal circuit breaker (1) with the handle (4).

3.3 Installation warnings

- make sure that the device work conditions (temperature of use, humidity, etc.) lie within the limits indicated; see chapter "TECHNICAL DATA"
- do not install the device near to any heat sources (heating elements, hot air ducts etc.), equipment containing powerful magnets (large diffusers, etc.), areas affected by direct sunlight, rain, humidity, excessive dust, mechanical vibrations or shocks
- in compliance with Safety Standards, the device must be installed correctly and in a way to protect against any contact with electric parts; all parts that ensure protection must be fixed in a way that they cannot be removed without the use of tools.

4 ELECTRIC CONNECTION

4.1 Preliminary notes

The magnitude detected by the auxiliary sensor (terminals 5 and 8) can be set through the P4 configuration parameter as follows:

- no magnitude (parameter P4 = 0)
- condenser temperature (parameter P4 = 1)
- critical temperature (parameter P4 = 2)
- evaporator temperature 2 (parameter P4 = 3)
- outgoing air temperature (parameter P4 = 4); in this case, the temperature associated with the setting shall be the CPT (Calculated Product Temperature) one

In the EVB1204 and EVB1214 models the application managed by the K4 digital output (terminals 13, 14 and 15) can be set by the u11 configuration parameter as follows:

- room light (parameter u1 = 0, default setting)
- demister heating elements (parameter u1 = 1)
- auxiliary output (parameter u1 = 2)
- alarm output (parameter u1 = 3)
- door heating elements (parameter u1 = 4)
- neutral area operating heating elements (parameter u1 = 5)
- condenser fan (parameter u1 = 6)
- compressor 2 (parameter u1 = 7)
- defrosting 2 (parameter u1 = 8)
- evaporator fan 2 (parameter u1 = 9)
- pump down valve (parameter u1 = 10)
- on/stand-by (parameter u1 = 11)
- man in cold room exit (parameter u1 = 12).

In the remaining models, the application managed by the K5 digital output, terminals 16 and 17 (K3 in the models with direct load connection, terminals 20 and 21) can be set through the u1 configuration parameter and that managed by the K6 digital output (terminals 13, 14 and 15) through the u11 configuration parameter as follows:

- demister heating elements (parameter u1 = 1)
- auxiliary output (parameter u1 and/or u11 = 2)
- alarm output (parameter u1 and/or u11 = 3, default setting for the K6 digital output)
- door heating elements (parameter u1 and/or u11 = 4)
- neutral area operating heating elements (parameter u1 and/or u11 = 5)
- condenser fan (parameter u1 and/or u11 = 6, default setting for the K5 digital output)
- compressor 2 (parameter u1 and/or u11 = 7)
- defrosting2 (parameter u1 and/or u11 = 8)
- evaporator fan 2 (parameter u1 and/or u11 = 9)
- pump down valve (parameter u1 and/or u11 = 10)
- on/stand-by (parameter u1 and/or u11 = 11)
- man in cold room exit (parameter u1 and/or u11 = 12).

Through the RS-485 MODBUS port it is possible to carry out on eof the following actions:

- device configuration, through the Parameters Manager set-up software system
- device data recording, through the EVUSBREC01 data recording device
- device supervision, through the CloudEvolution system monitoring and supervision (via Web) system
- use of the MODBUS slave function through third party devices.

The port must not be used for more than one of these purposes at the same time.

Please see paragraph "Setting the configuration parameters" for the settings of the configuration parameters.

For additional information, please refer to the following paragraphs.

4.2 Electric connection for models EVB1204 and EVB1214

The following drawing shows the electric connections for the EVB1204 and EVB1214 models.

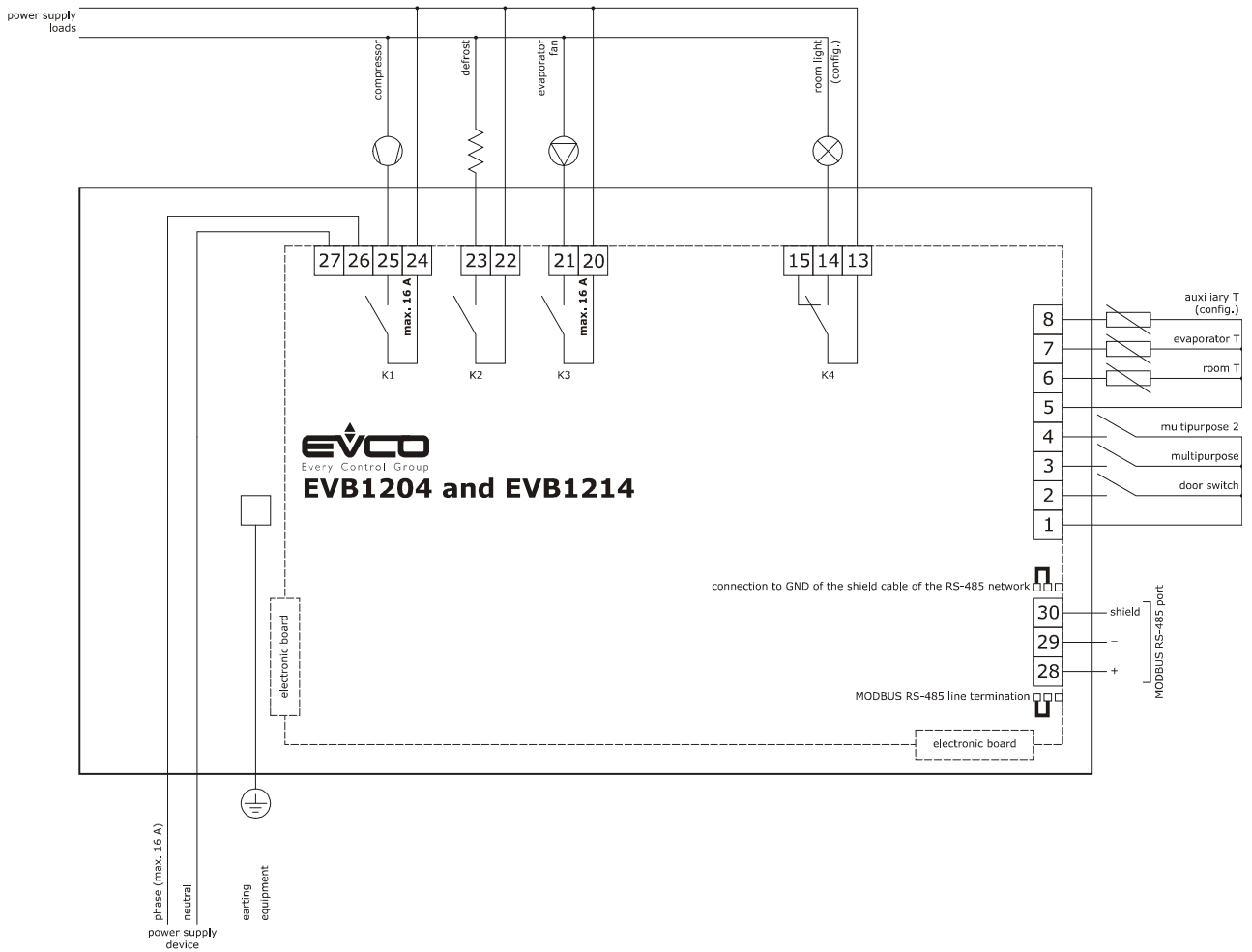

4.3 Electric connection for models EVB1206 and EVB1216

The following drawing shows the electric connections for the EVB1206 and EVB1216 models.

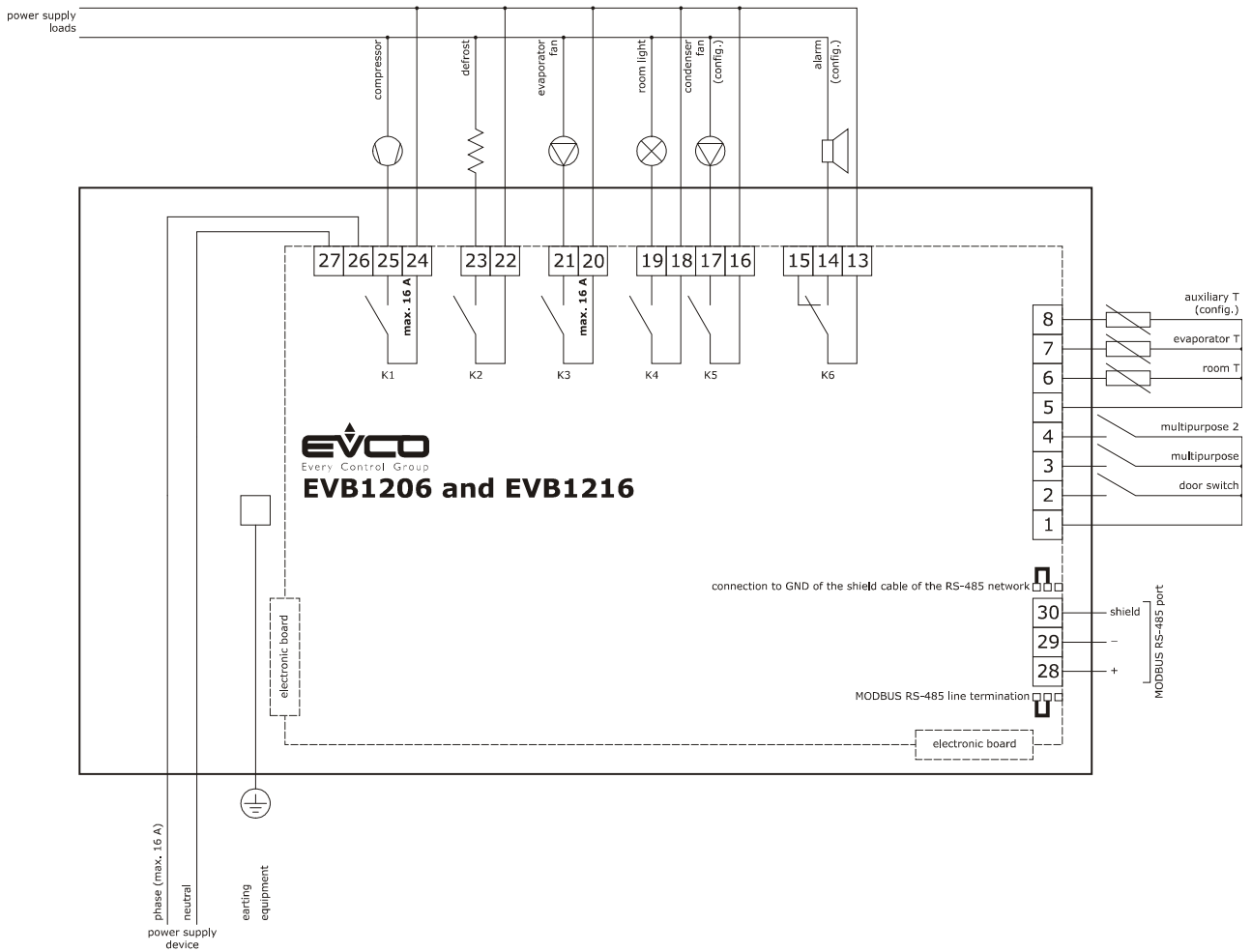

4.4 Electric connection for models EVB1226 and EVB1236

The following drawing shows the electric connections for the EVB1226 and EVB1236 models.

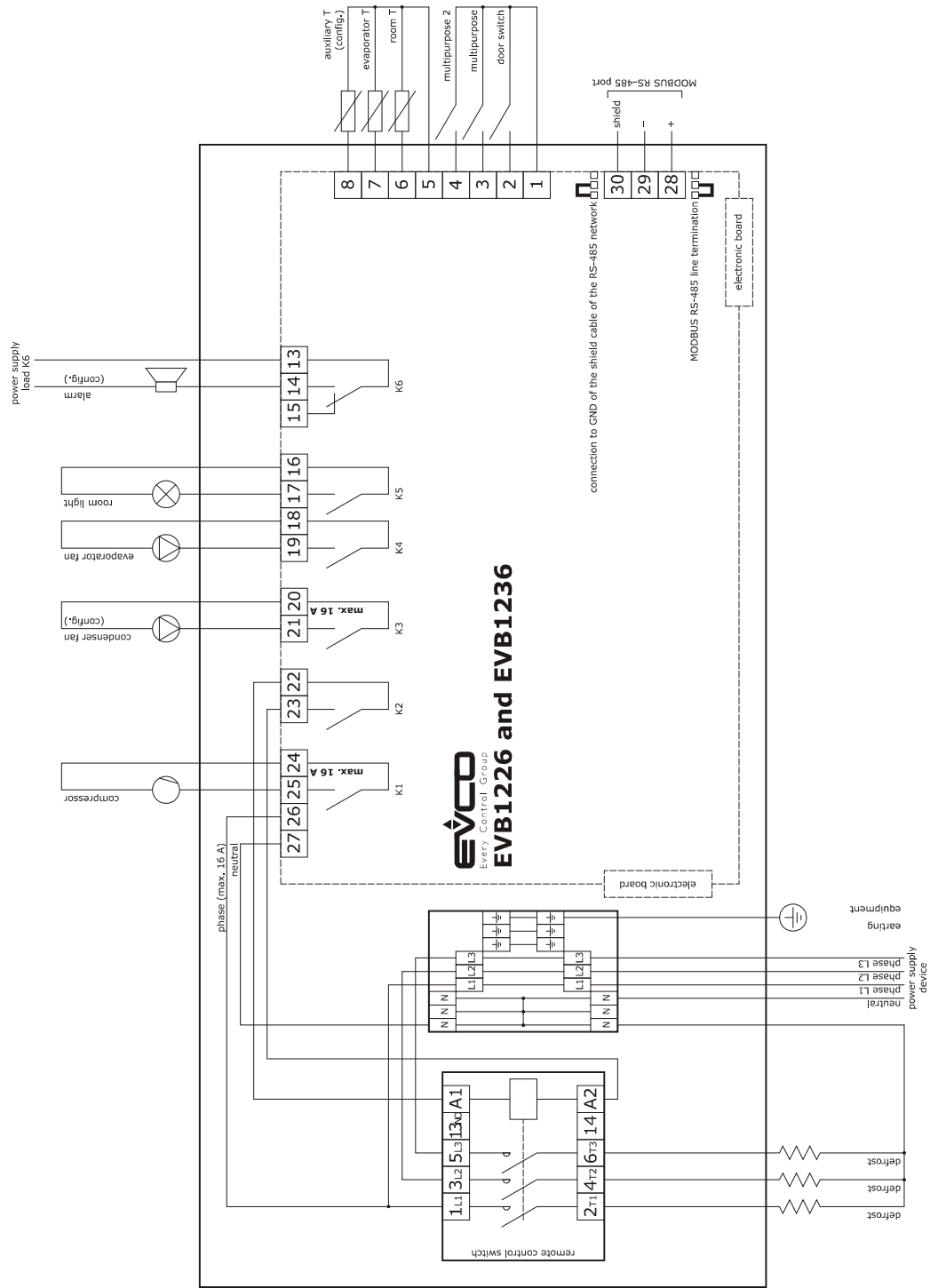

4.6 Electric connection for models with direct loads connection (example for EVB1216N9XXC)

The following drawing shows the electric connections for models with direct loads connection (example EVB1216N9XXC).

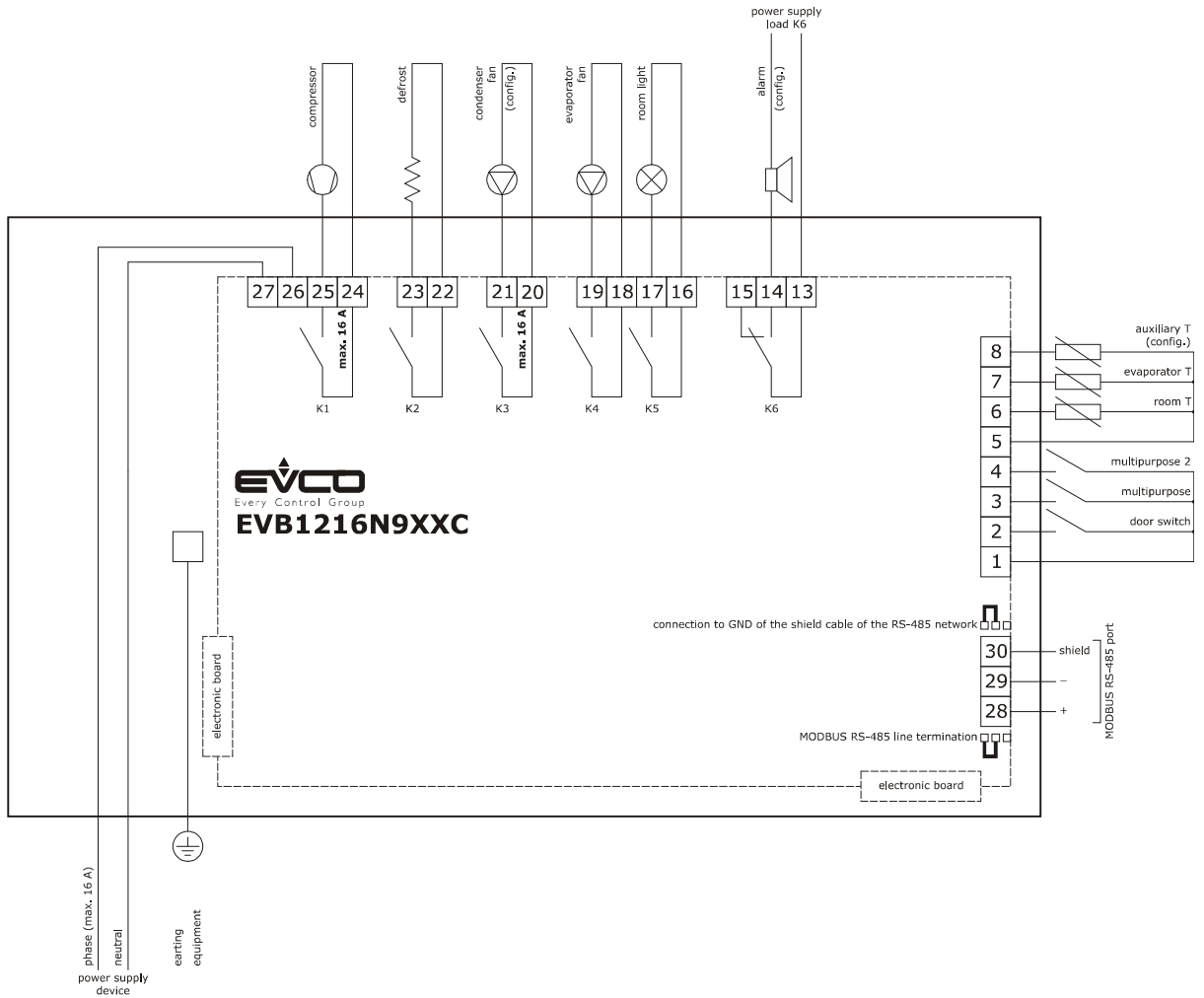

4.7 Electric connection for models with data logging extension for EN 12830 standard compliance (example for EVB1214N9XLC)

The following drawing shows the electric connections for models with data logging for EN 12830 standard compliance (example EVB1214N9XLC).

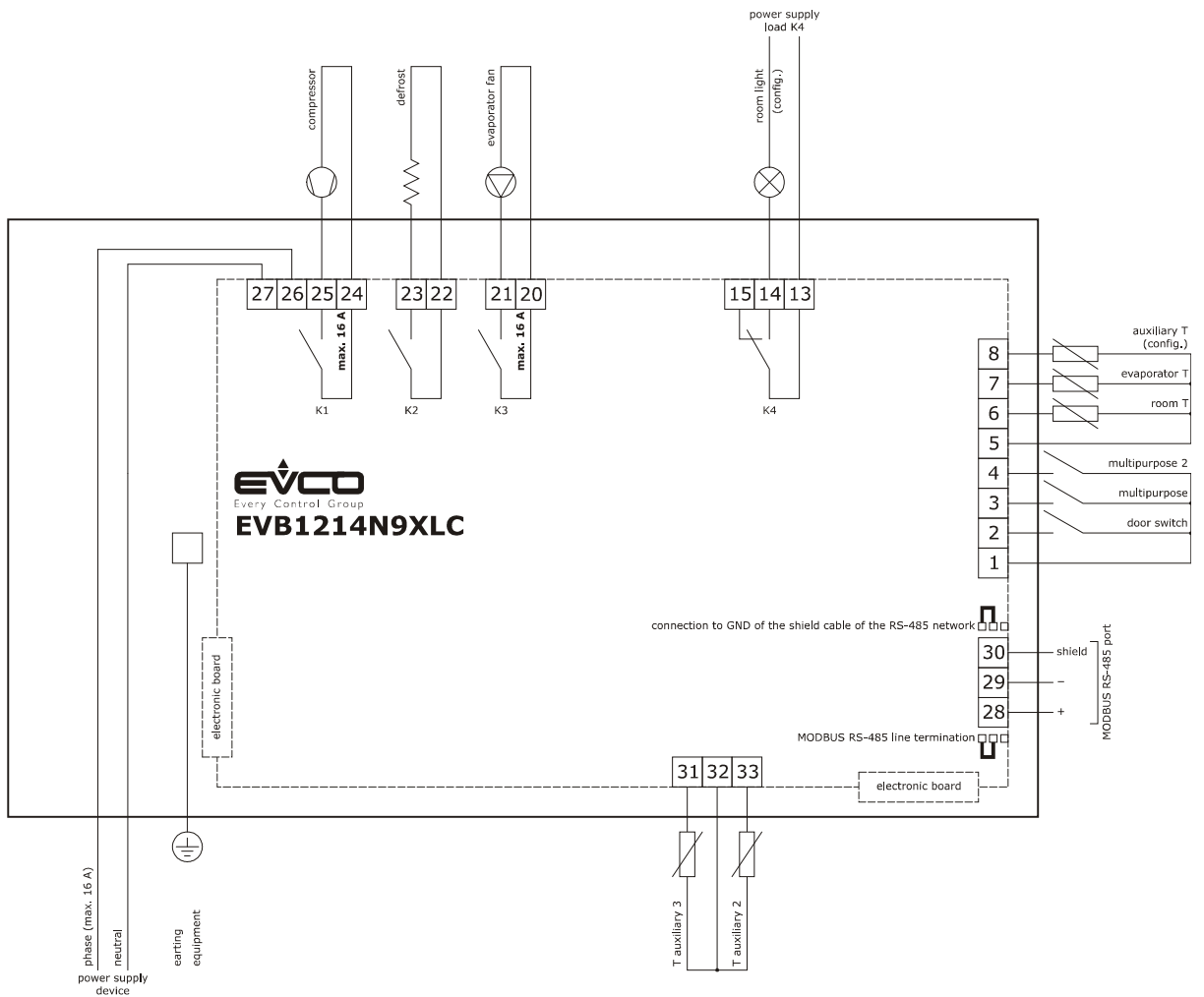

4.8 Electric connection for models with magneto-thermal switch or differential magneto-thermal circuit breaker (example for EVB1256N9D)

The following drawing shows the electric connections for models with magneto-thermal switch or differential magneto-thermal circuit breaker (example EVB1256N9D).

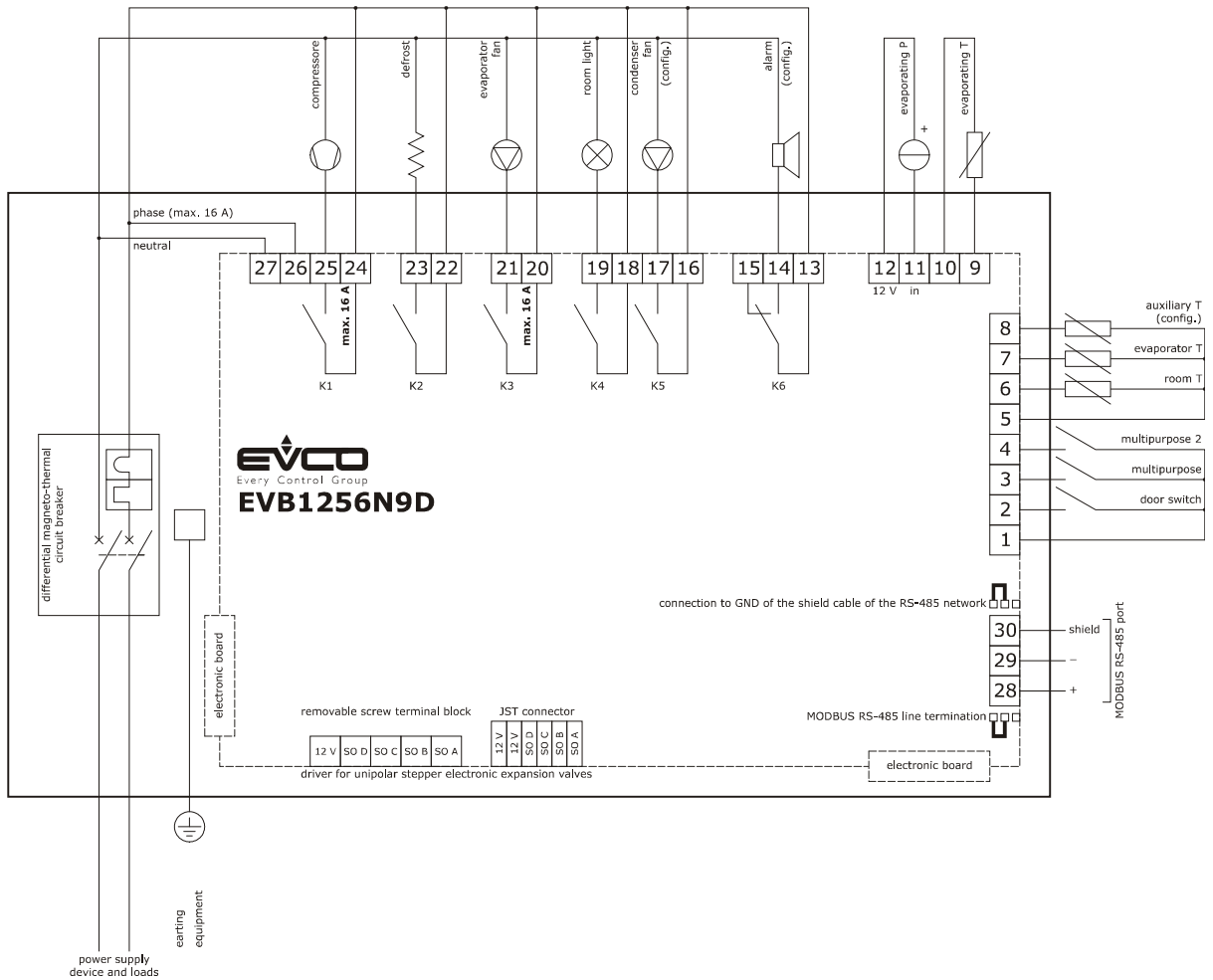

4.9 Insertion of the RS-485 MODBUS port termination resistor

To reduce reflections on the signal transmitted through the cables connecting the devices to a RS-485 network it is necessary to insert the termination resistor of the first and last elements of the network.

To insert the termination resistor place the jumper as shown in the following drawing.

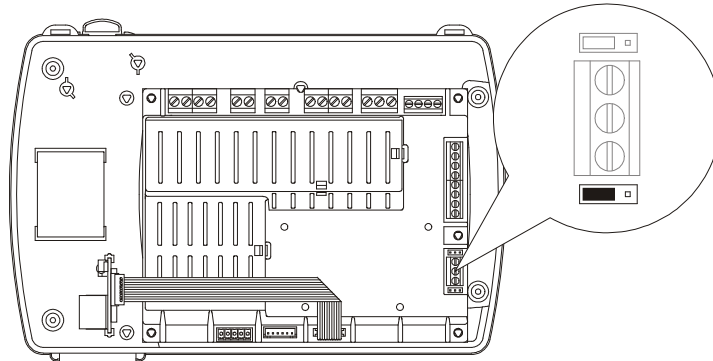

4.10 Connection of the RS-485 network cable screen to GND

To prevent external disturbances from being interpreted as signals by the RS-485 network, it might be necessary to connect the cable screen of the RS-485 network to GND

To connect the cable screen to GND, place the jumper as shown in the following drawing.

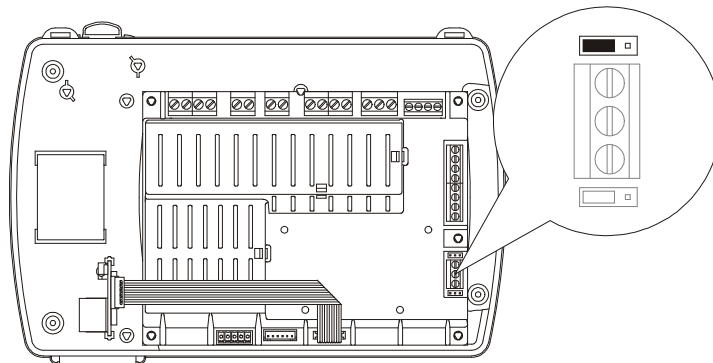

4.11 Warnings for the electric connection

- do not use electric or pneumatic screwdrivers on the device terminal board
- if the device has been taken from a cold to hot place, humidity could condense inside; wait about 1 hour before powering it
- make sure that the power supply voltage, the frequency and the operational electric power of the device, correspond with those of the local power supply; see chapter "TECHNICAL DATA"
- disconnect the device power supply before proceeding with any type of maintenance
- connect the device to a RS-485 MODBUS network using a twisted pair
- position the power cables as far away as possible from the signal cables
- for repairs and information regarding the device, contact the EVCO sales network.

5 FIRST USE

5.1 First use

Operate as follows:

1. Install the device as described in chapter "DIMENSIONS AND INSTALLATION" , following in particular the instructions of paragraph "Installation warnings".
2. Make the relevant electric connections for the device as shown in chapter "ELECTRIC CONNECTION", following in particular the instructions of paragraph "Warning for the electric connection", without connecting the device or the loads power supply.
3. Connect the device power supply: this shall launch an internal test.
The test typically takes a few seconds to complete; at the end of the test, the display turns off.
4. If, at the end of the test, the letters "**rtc**" flash on the screen and the buzzer sounds intermittently, it will be necessary to set the date, time and day of the week; please refer to paragraph 13.1 "Setting the date, time and day of the week (only in the models with clock)".
5. Configure the device using the procedure described in paragraph "Setting the configuration parameters",
The following table shows the meaning of the main configuration parameters; the parameters are shown in the order with which it is best to configure the device.

PARAM.	MEANING	DEFAULT SETTINGS
P0	temperature probe type 0 = PTC 1 = NTC 2 = Pt 1000	1
P2	temperature unit of measurement 0 = °C 1 = °F	0
P9	pressure transducer minimum setting	0.5
P10	pressure transducer maximum setting	7.0
SP	work set-point	-18,0 °C
r0	working set-point differential	2.0 °C
d0	type of defrosting 0 = electric 1 = by hot gas 2 = via stopping of compressor	0
d3	maximum defrosting duration	30 min

<p>u1</p>	<p>in the EVB1204 and EVB1214 models, the application is managed through the K4 digital output</p> <ul style="list-style-type: none"> 0 = man in cold room exit 1 = demister heating elements 2 = auxiliary output 3 = alarm output 4 = door heating elements 5 = neutral area operating heating elements 6 = condenser fan 7 = compressor 2 8 = defrosting2 9 = evaporator fan 2 10 = pump down valve 11 = on/stand-by 12 = man in cold room exit 	<p>0</p>
<p>u1</p>	<p>in the remaining models, the application is managed by the K5 digital output (K3 in the models with direct load connection)</p> <ul style="list-style-type: none"> 0 = reserved 1 = demister heating elements 2 = auxiliary output 3 = alarm output 4 = door heating elements 5 = neutral area operating heating elements 6 = condenser fan 7 = compressor 2 8 = defrosting2 9 = evaporator fan 2 10 = pump down valve 11 = on/stand-by 12 = man in cold room exit 	<p>6</p>
<p>u11</p>	<p>if present, the application is managed by the K6 digital output</p> <ul style="list-style-type: none"> 0 = reserved 1 = demister heating elements 2 = auxiliary output 3 = alarm output 4 = door heating elements 5 = neutral area operating heating elements 6 = condenser fan 7 = compressor 2 8 = defrosting2 9 = evaporator fan 2 10 = pump down valve 11 = on/stand-by 12 = man in cold room exit 	<p>3</p>

Then, check that the remaining settings are appropriate; refer to paragraph 13.5 "List of configuration parameters".

6. Connect the loads power supply
7. Turn the device on; refer to paragraph "Device switch-on/off in manual mode".

For additional information, please refer to the following paragraphs.

6 USER INTERFACE

6.1 Preliminary notes

Operating Statuses:

- "on" state (the device is powered and is on: the regulators can be switched on)
- "stand-by" status (the device is powered but is switched off via software: the regulators are switched off; the possibility to turn the room light or the auxiliary output on/off manually depends on parameter u2)
- the "off" status (the device is not powered).

Hereafter, with the word "start-up" means the passage from "stand-by" status to "on" status; the word "shutdown" means the passage from "on" status to "stand-by" status.

When the power is switched back on, the device displays the status that it was in at the time it was disconnected.

6.2 Device switch-on/off in manual mode

To turn the device on/off in manual mode, proceed as follows:

1. Make sure that the keyboard is not locked and that no procedure is in progress.
2. Hold the key "ON/STAND-BY" for 2 s.

Using the digital inputs it is also possible to remotely switch on/off the device.

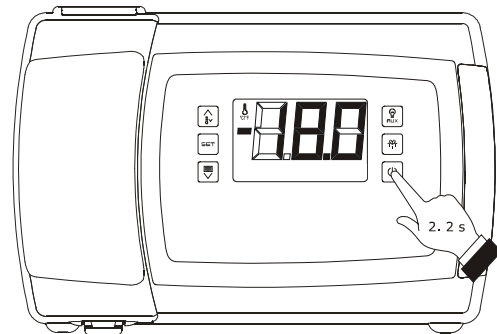

Device switch-on/off in manual mode

6.3 The display

If the device is switched on, during normal operation, the display will show the magnitude established with P5, except during defrosting, when the device will show the temperature established with parameter d6.

If the device is switched off, the display will be switched off.

6.4 Displaying the magnitude detected by an analogue input

To display the magnitude detected by an analogue input, proceed as follows:

1. Make sure that the keyboard is not locked and that no procedure is in progress.
2. Hold the key "DOWN" for 1 s: the display will show the first label available.
3. Press and release the key "UP" or "DOWN" to select a label.

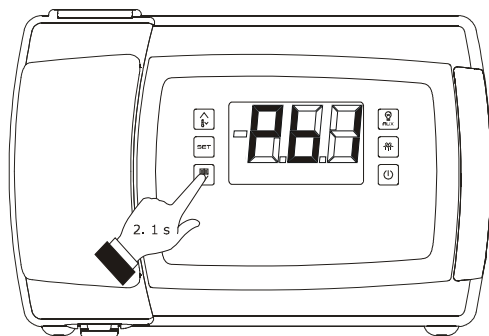

Access the procedure to display the quantity detected by an analogue input

The following table shows the correspondence between the labels and the magnitudes displayed for models EVB1246 and EVB1256.

LABEL	MAGNITUDE
Pb1	room/inflowing air temperature; see also parameter P4
Pb2	evaporator temperature
Pb3	auxiliary temperature; see also parameter P4
Pb4	if present, vapour pressure
Pb5	if present, evaporation temperature
Pb6	CPT temperature; see also parameter P4
Pb7	if present, auxiliary 2 temperature
Pb8	if present, auxiliary 3 temperature

The following table shows the correspondence between the labels and the magnitudes displayed for the remaining models.

LABEL	MAGNITUDE
Pb1	room/inflowing air temperature; see also parameter P4
Pb2	evaporator temperature
Pb3	auxiliary temperature; see also parameter P4
Pb4	CPT temperature; see also parameter P4
Pb7	if present, auxiliary 2 temperature
Pb8	if present, auxiliary 3 temperature

4. Press and release the key "SET".

To exit the procedure:

5. Press and release the key "SET" or do not operate for 60 sec.
6. Press and release the "UP" or "DOWN" key until the display shows the magnitude established with parameter P5 or do not operate for 60 sec.

Alternatively:

7. Press and release the "ON/STAND-BY" key.

If the evaporator temperature sensor is not present (or if the P3 parameter is set to 0), the "Pb2" label shall not be displayed.

If the auxiliary temperature sensor is not present (or if the P4 parameter is set to 0), the "Pb3" label shall not be displayed.

If the auxiliary 3 temperature sensor is not present (or if the Sd3 parameter is set to 0), the "Pb8" label shall not be displayed.

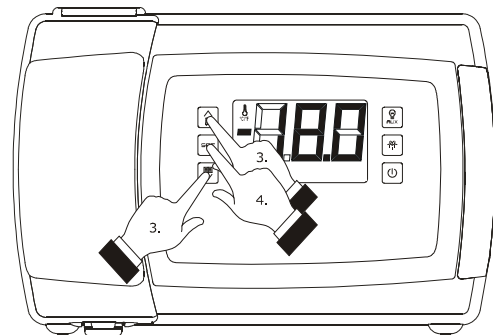

Displaying the magnitude detected by an analogue input

6.5 "Rapid cooling" function enabling/disabling

To enable/disable the "rapid cooling" function, proceed as follows:

1. Check that the device is turned on, that the keypad is not locked, that no procedures are in progress and that there are no defrosting, dripping or evaporator fan stop operations in progress.
2. Keep the "UP" key pressed for 4 s: the "temperature" LED light shall start flashing.

During the "rapid cooling" function the work set point is decreased by the temperature set with the r5 parameter; the function runs for the span of time set with the r6 parameter.

During the "rapid cooling" function the defrosting function is never activated; if the defrosting interval expires while the rapid cooling function is in progress, the defrosting shall be activated at the end of the cooling.

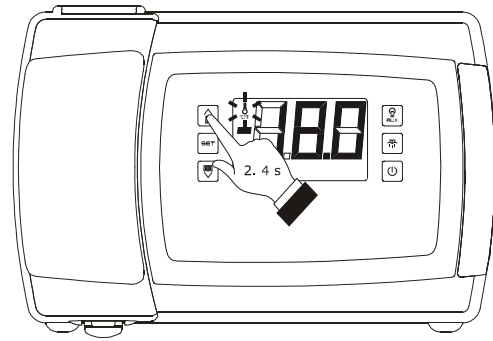

"Rapid cooling" function enabling/disabling

6.6 Defrosting manual activation

To activate the defrosting in manual mode, proceed as follows:

1. Check that the device is turned on, that the keypad is not locked, that no procedures are in progress and that the "rapid cooling" function is not in progress.
2. Keep the "DEFROSTING" key pressed for 4 s.

If the evaporator temperature sensor functions as a defrosting sensor (that is to say, if the P3 parameter is set to 1) and when the defrosting starts the evaporator temperature exceeds the value set with the d2 parameter, the defrosting shall not be activated.

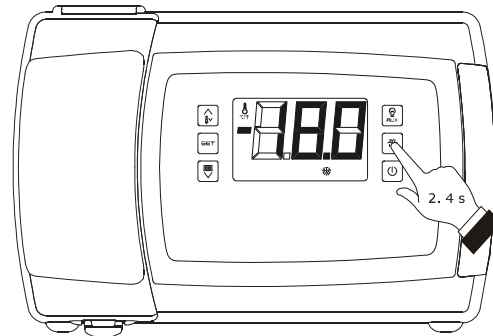

Defrosting manual activation

6.7 Turning on/off of room lights manually (only if the parameter u1 and/or parameter u11 is set at 0)

To turn the room light on/off in manual mode, proceed as follows:

1. Make sure no procedures are in progress.
2. Press and release the "AUXILIARY" key: the "room light" LED shall turn on/off.

Through the digital ports it is also possible to turn the room light on/off from remote; see parameter u2.

If parameter u1 and/or parameter u11 are set to 2 (that is to say, if the application managed by the K5 and/or K6 outputs is the auxiliary output), pressing the "AUXILIARY" key for 2 s shall make the "auxiliary 1" and/or "auxiliary 2" and the auxiliary output LEDs turn on/off.

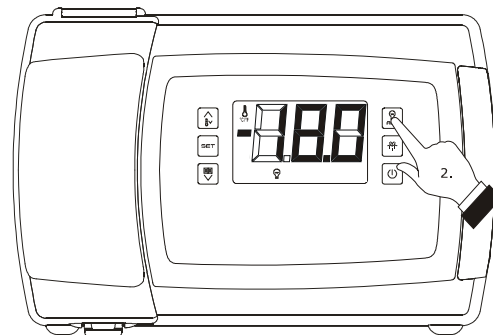

Turning on/off of room lights in manual mode

6.8 Turning the demister heating elements on/off manually (only if the parameter u1 and/or parameter u11 is set at 1)

To turn the demister heating elements on, proceed as follows:

1. Check that the device is turned on and no procedures are in progress.
2. Keep the "AUXILIARY" key pressed for 2 s: the "AUX1" and/or "AUX2" LEDs shall light up and the heating elements be turned on, both for the length of time set with the parameter u6.

The demister heating elements cannot be turned off in manual mode (that is to say, before the time set with the parameter u6 has expired).

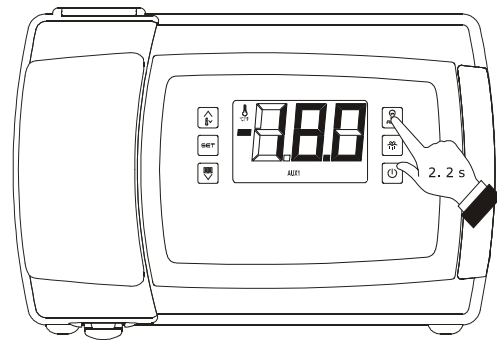

Demister heating elements manual activation

6.9 Turning on/off of the auxiliary output manually (only if the parameter u1 and/or parameter u11 is set at 2)

To turn the auxiliary output on/off in manual mode, proceed as follows:

1. Make sure that the keyboard is not locked and that no procedure is in progress.
2. Keep the "AUXILIARY" key pressed for 2 s: the "AUX1" and/or "AUX2" LEDs shall turn on/off.

Through the digital ports it is also possible to turn the auxiliary output on/off from remote; see parameter u2.

If the auxiliary output has been turned on manually, it shall be possible to turn it off only in the same mode (similarly, if it was turned on from remote, it shall be possible to turn it off only from remote); see also parameter u2.

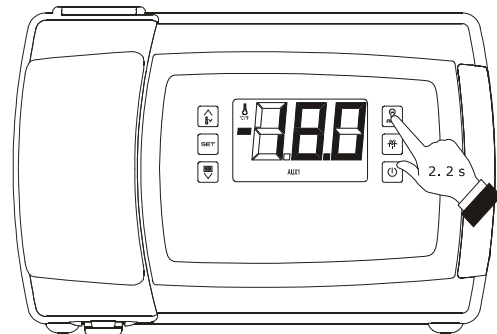

Turning on/off of the auxiliary output manually

6.10 Displaying some instant values joined to the electronic expansion valve (only in models EVB1246 and EVB1256)

To display some instant values joined to the electronic expansion valve, proceed as follows:

1. Make sure that the keyboard is not locked and that no procedure is in progress.
2. Hold the key "DOWN" for 1 s: the display will show the first label available.
3. Press and release the key "UP" or "DOWN" to select a label.

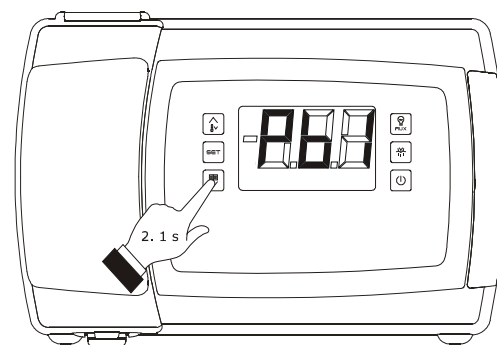

Access the procedure to display some instant values joined to the electronic expansion valve

The following table shows the correspondence between the labels and the magnitudes displayed.

LABEL	MAGNITUDE
SH	instant superheating
POS	percentage (required) valve open
POr	percentage (instant) valve open

4. Press and release the key "SET".

To exit the procedure:

5. Press and release the key "SET" or do not operate for 60 sec.
6. Press and release the "UP" or "DOWN" key until the display shows the magnitude established with parameter P5 or do not operate for 60 sec.

Alternatively:

7. Press and release the "ON/STAND-BY" key.

6.11 Keyboard locking/unlocking

To lock the keyboard proceed as follows:

1. Check that the device is turned on and no procedures are in progress.
2. Keep the "DOWN" and "ON/STAND-BY" keys pressed for 1 s: the word "Loc" shall be displayed on screen for 1 s.

If the keyboard is locked, the following are not permitted:

- device switch-on/off in manual mode
- display of a magnitude recorded by an analogue input (with the procedure described in paragraph 6.4 "Displaying the magnitude detected by an analogue input")
- activation/deactivation of "rapid cooling" function
- manual activation of defrosting
- activation of the low or high relative humidity percentage operation mode to learn how it works
- see information regarding the HACCP alarms
- cancellation of HACCP alarm list
- display of compressor operation hours
- cancellation of compressor operation hours

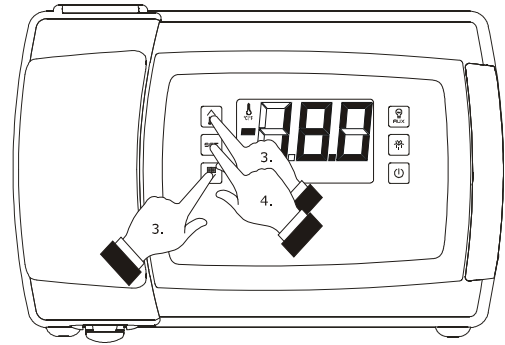

Displaying some instant values joined to the electronic expansion valve

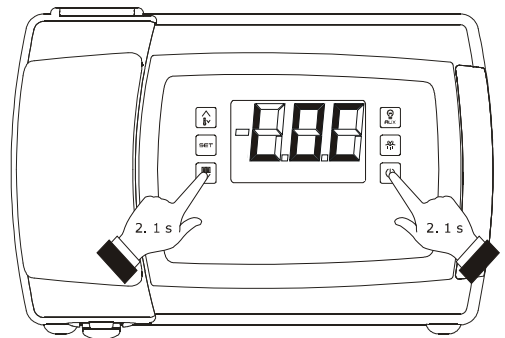

Keyboard locking

- set the working set point (with the procedure described in paragraph "Setting the working set point").

The operations cause the display of the label "**Loc**" for 1 s.

To unlock the keyboard:

3. Hold the "DOWN" key and the "ON/STAND-BY" key for 1 s: the display will show the message "**UnL**" for 1 s.

6.12 Silencing the buzzer

To silence the buzzer, proceed as follows:

1. Make sure no procedures are in progress.
2. Press a key (the first pressing of the key will not cause the effect associated with that key).

If the parameter u1 and/or the parameter u11 is set at 3 (i.e. the utility managed by the digital output K5 and/or K6 is the alarm output) and parameter u4 is set at 1, pressing the key will also cause the deactivation of the output.

If parameter u9 is set at 0, the buzzer will not be activated.

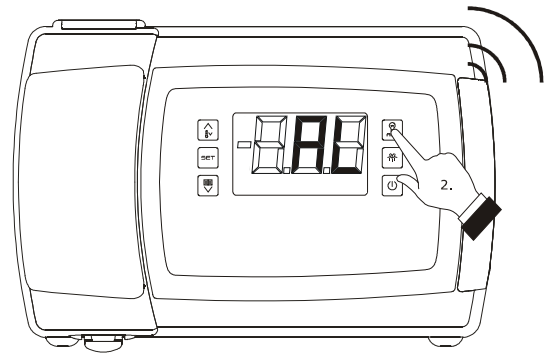

Silencing the buzzer

7 OPERATION WITH LOW OR HIGH RELATIVE HUMIDITY PERCENTAGES (ONLY IF THE F0 PARAMETER IS SET TO 5)

7.1 Preliminary notes

During operation with a low relative humidity percentage, the evaporator fan shall be turned on if the compressor is on, and shall turn on cyclically if the compressor is off (the F4 parameter determines the duration of the off phase of the fan and the F5 parameter determines the on phase).

During operation with a high relative humidity percentage, the evaporator fan is always on.

7.2 Manual activation of the low and high relative humidity percentages operating mode

To activate the the low or high relative humidity percentages operating mode manually, proceed as follows:

1. Ensure that the device is on, the keypad is not locked and that no procedure is in progress.
2. Keep the "SET" and "UP" keys pressed for 4 s: the letters "**rhL**" (operation with low relative humidity percentage) or "**rhH**" (operation with high relative humidity percentage) shall be displayed on screen for 10 s.

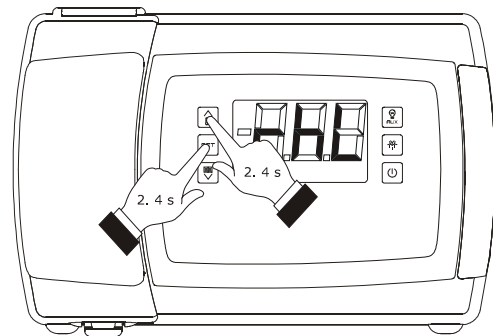

Manual activation of the low and high relative humidity percentages operating mode

To restore the normal display before time:

3. Press any key.

It is also possible to activate the low or high relative humidity percentage operation mode with the F6 parameter.

If the F0 parameter is not set to 5, pressing the keys shall make the message "- -" appear on display for 1 s.

7.3 Learning the current operating mode

To learn which operating mode is in progress proceed as follows:

1. Check that the device is turned on and no procedures are in progress.
2. Press and release the "SET" and "UP" keys: the letters "**rhL**" (operation with low relative humidity percentage) or "**rhH**" (operation with high relative humidity percentage) shall be displayed on screen for 10 s.

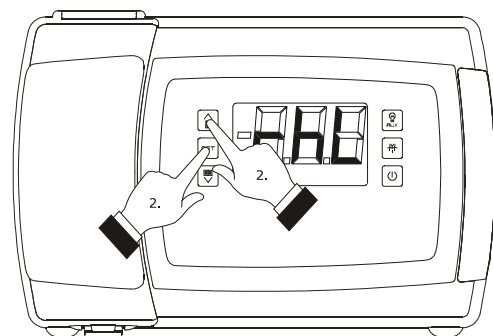

Learning the current operating mode

8 "ENERGY SAVING" FUNCTION

8.1 Preliminary notes

Once the time you have set with parameter i10 has passed, without activations of the door micro switch input (after the room temperature has reached the work set point) the "energy saving" function is activated (until the input is activated again).

During the "energy saving" function, the work set point is increased by the temperature established with parameter r4 and the evaporator fan is turned on cyclically, provided that the F0 parameter is set to 1, 2, 3 or 4 (parameter F13 establishes the duration of fan switch off and parameter F14 that of switch on).

It is also possible to activate the "energy saving" function in remote mode through the digital inputs (with effect only on the compressor).

9 "CPT" FUNCTION (CALCULATED PRODUCT TEMPERATURE)

9.1 Preliminary notes

If parameter P4 is set at 4, the temperature associated to the regulation will mainly depend on the temperature detected by the inlet air probe and that detected by the air outlet probe, herein called CPT temperature (Calculated Product Temperature); the room temperature probe shall operate as an air inlet temperature probe and the auxiliary temperature probe as an air outlet temperature probe.

The formula for the calculation of the CPT temperature is:

$$\text{CPT temperature} = \{[(\text{value established with parameter P7}) \times (\text{temperature detected by the inlet air probe})] : 100\} + \{[(100 - \text{value established with parameter P7}) \times (\text{temperature detected by the outlet air probe})] : 100\}.$$

10 "HACCP" FUNCTION

10.1 Preliminary notes

The device can memorise the following HACCP alarms:

- minimum temperature alarm (code "AL")
- maximum temperature alarm (code "AH")
- door micro switch input alarm (code "id")
- power supply cut-off alarm (code "PF"; only in the models with clock).

The device can memorise up to 9 alarms, after which the oldest alarm is overwritten.

The device supplies the following information for every alarm:

- the critical value
- the date and time at which the alarm occurs (only in the models with clock)
- the duration of the alarm (from 1 min to 99 hours and 59 min, partial if the alarm is in progress).

The following table shows the correspondence between the alarm codes and the relevant critical values.

CODE	CRITICAL VALUE
AL	the minimum room temperature or the minimum CPT temperature during the alarm
AH	the maximum room temperature or the maximum CPT temperature during the alarm
id	the maximum room temperature or maximum CPT temperature during any alarm of this type; see also parameter i4
PF	the room temperature or the CPT temperature when power supply is restored; see also parameters A10 and A12

Models without clock update the information regarding the alarms provided the critical value of the new alarm is more critical than that stored or provided the information has already been displayed.

If the device is switched off, no alarms will be stored.

The "HACCP" LED provides information regarding the storage status of the alarms; see paragraph "Signals".

10.2 Display of HACCP alarm information

To begin the procedure:

1. Make sure that the keyboard is not locked and that no procedure is in progress.
2. Hold the key "DOWN" for 1 s: the display will show the first label available.
3. Press and release the "UP" or "DOWN" key to select "LS".
4. Press and release the "SET" key:
 - 4.1 in the models without a clock the display will show one of the codes included in the table in paragraph "Preliminary notes"
 - 4.2 in the models with a clock the display will show one of the codes included in the table in paragraph "Preliminary notes" followed by a number; the higher the number, the less current the alarm.

If the device does not have any alarms stored, the label "LS" will not be displayed.

To select an alarm:

5. Press and release the "UP" key or the "DOWN" key.

To see information regarding the alarm:

6. Press and release the "SET" key: the HACCP LED will stop flashing and remain on permanently and the display will show, for example, the following information in succession:

INFORM.	MEANING
8.0	the critical value is 8.0 °C/8 °F
StA	the display is about to show the date and time at which the alarm occurs (only in the models with clock)
y14	the alarm occurred in 2014 (continue...)
n03	the alarm occurred in the month of March (continue...)
d26	the alarm occurred on 26 March 2014 (continue...)
h16	the alarm occurred at 16:00 (continue...)
n30	the alarm occurred at 16:30

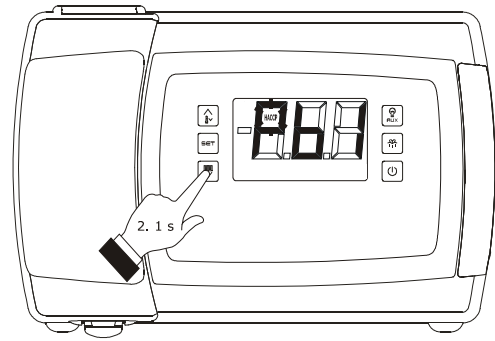

Access the procedure to display information on the HACCP alarms

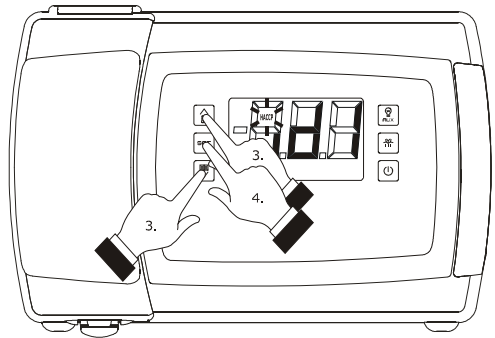

Selection of information on the HACCP alarms

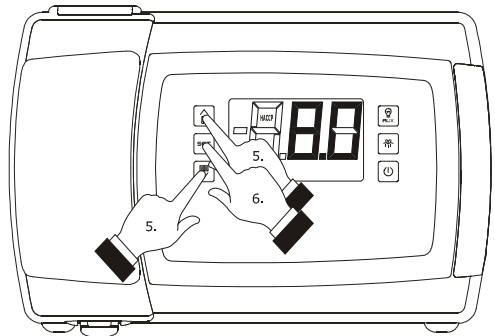

Display of information on the HACCP alarms

dur	the display is about to show the alarm duration
h01	the alarm lasted for 1 hour (continue...)
n15	the alarm lasted 1 hour and 15 min
code	the alarm selected

the displays each piece of information for 1 s.

To exit the information sequence:

- Press and release the "ON/STAND-BY": the display will show the alarm selected.

To exit the procedure:

- Exit the information sequence.
- Press and release the "UP" or "DOWN" key until the display shows the magnitude established with parameter P5 or do not operate for 60 sec.

Alternatively:

- Press and release the "ON/STAND-BY" key.

10.3 Cancelling the HACCP alarm list

To cancel the HACCP alarm list proceed as follows:

- Make sure that the keyboard is not locked and that no procedure is in progress.
- Hold the key "DOWN" for 1 s: the display will show the first label available.
- Press and release the "UP" or "DOWN" key to select "rLS".
- Press and release the "SET" key.
- Press and release the "UP" or "DOWN" key within 15 s to set "149".
- Press and release the "SET" or do not operate for 15 sec: the display will show a flashing "--" for 4 sec and the "HACCP" LED switches off, after which the device will exit the procedure.

If the device does not have any alarms stored, the label "rLS" will not be displayed.

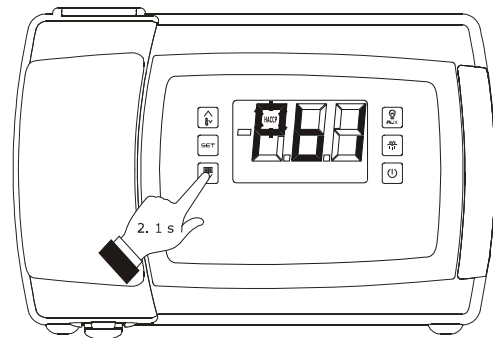

Access the procedure to cancel information on the HACCP alarms

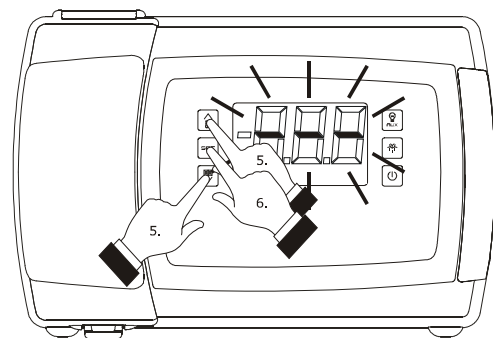

Cancelling information on the HACCP alarms

11 DATA LOGGING EXTENSION FOR EN 12830 STANDARD COMPLIANCE

11.1 Preliminary information

Some devices have a data logging extension for EN 12830 standard compliance.

Through the extension it is possible to write information about the device into a CSV file, on SD card (not included).

The devices have the following writing modes:

- "HACCP" mode; in this case a file is generated daily and another one monthly (the kind of information written on them is the same)
- "service" mode; in this case it is generated just one file.

The "HACCP" writing mode is always active; the "service" writing mode must be activated with the procedure shown in paragraph "11.3.2 Activating the "service" writing mode".

The activation of the "service" writing mode has not effect on the "HACCP" one.

If the device is switched off, no information will be written.

The SD card status LED provides information on the writing; look at paragraph 14.1 "Signals".

To allow verifying the integrity of the information, into the files it is also written a signature based on a system of cryptographic keys; to highlight a possible alteration, a free software is available on www.evco.it.

11.2 "HACCP" writing mode

The device writes into the CSV file the following information:

- the value of the room temperature
- the value of the temperature detected by the auxiliary 2 probe
- the value of the temperature detected by the auxiliary 3 probe (if available).

Parameter Sd0 sets the writing interval.

The device also writes into the CSV file information about the following events:

- alarms activation/deactivation
- errors activation/deactivation
- device switching on/off
- defrost activation/end
- function "energy saving" activation/deactivation
- auxiliary 3 probe activation/deactivation
- power supply restoring.

When these events arise the device records the value of the temperature detected by all the probes.

For each information the device records the time it has been recorded.

In absence of power supply a battery guarantees the writing into the CSV file of information about the auxiliary 2 probe and about the auxiliary 3 probe (they are electrically independent on the device power supply) and of information about the lack of power supply; the battery range in absence of power supply is more than 72 h.

The following drawing shows the aspect of a file written with the "HACCP" writing mode.

	A	B	C	D	E	F	G	H	I	J	K	L	
1	LOG247_2015_01_07						Signature						
2	EVBOX1214						Version						
3	Address	247					E767C1DCC						
4	Date	07/01/2015					E5428EF05						
5	Time	Cab Temp	Evap Temp	Aux2 Temp	Alarm	Event	E10B24EF7						
6	dd/mm/yy hh:mm	°C	°C	°C			EF73E517F						
7	07/01/2015 12:27	-27,6	-19,5	-11,0		POWER UP	EEE333462						
8	07/01/2015 12:29	-27,7	-19,5	-11,0			E5428EF05						
9	07/01/2015 12:30		-19,5	-11,0	PR1 ON		E5428EF05						
10	07/01/2015 12:33		-19,5	-11,1			E5428EF05						
11	07/01/2015 12:34		-19,5	-11,0	PR1 ON		E10B24EF7						
12	07/01/2015 12:35	-27,7	-19,5	-11,0			EF73E517F						

11.3 "Service" writing mode

11.3.1 Preliminary information

The device writes into the CSV file the following information:

- the value of the temperature detected by all the probes
- the value of the superheating (if available)
- the percentage the electronic expansion valve is open (if available).

Parameter Sd1 sets the writing interval; parameter Sd2 sets the duration of the writing mode.

The device also writes into the CSV file information about the following events:

- alarms activation/deactivation
- errors activation/deactivation
- device switching on/off
- defrost activation/end
- function "energy saving" activation/deactivation
- probes activation/deactivation
- loads switching on/off
- power supply restoring.

When these events arise the device records the value of the temperature detected by all the probes.

For each information the device records the time it has been recorded.

The following drawing shows the aspect of a file written with the "service" writing mode.

	A	B	C	D	E	F	G	H	I	J	K	L	L
1	SER247_1												Signature V1.0
2	EVBOX1214												EEE333462
3	Address	247											E767C1DCC
5	Date	07/01/2015											E5428EF05
6	Time	Cab Temp	Evap Temp	Aux1 Temp	Suct Temp	Suct Press	SH value	EEV %	Aux2 Temp	Aux3 Temp	Alarm	Event	E10B24EF7
7	dd/mm/yy hh:mm	°C	°C	°C					°C	°C			EF73E517F
8	07/01/2015 12:27	-27,6	-19,5	-11,0	-11,0	4,2	4,2	11,0	-11,0	4,2		POWER UP	EEE333462
9	07/01/2015 12:28	-27,6	-19,5	-11,1	-11,1	4,2	4,2	11,1	-11,1	4,2			E767C1DCC
10	07/01/2015 12:29	-27,7	-19,5	-11,0	-11,0	4,2	4,2	11,0	-11,0	4,2			E5428EF05
11	07/01/2015 12:30		-19,5	-11,0	-11,0	4,2	4,2	11,0	-11,0	4,2	PR1 ON		E5428EF05
12	07/01/2015 12:31		-19,5	-11,0	-11,0	4,2	4,2	11,0	-11,0	4,2			E10B24EF7
13	07/01/2015 12:32		-19,5	-11,1	-11,1	4,2	4,2	11,1	-11,1	4,2			EF73E517F
14	07/01/2015 12:33		-19,5	-11,1	-11,1	4,2	4,2	11,1	-11,1	4,2			E5428EF05
15	07/01/2015 12:34		-19,5	-11,0	-11,0	4,2	4,2	11,0	-11,0	4,2	PR1 ON		E10B24EF7
16	07/01/2015 12:35	-27,7	-19,5	-11,0	-11,0	4,2	4,2	11,0	-11,0	4,2			EF73E517F
17	07/01/2015 12:36	-27,6	-19,5	-11,0	-11,0	4,1	4,1	11,0	-11,0	4,1			EEE333462
18	07/01/2015 12:37	-27,6	-19,5	-11,0	-11,0	4,2	4,2	11,0	-11,0	4,2			E767C1DCC
19	07/01/2015 12:38	-27,7	-19,5	-11,0	-11,0	4,1	4,1	11,0	-11,0			AUX3 DISABLED	E5428EF05
20	07/01/2015 12:39	-27,6	-19,5	-11,0	-11,0	4,2	4,2	11,0	-11,0				E10B24EF7
21	07/01/2015 12:40	-27,7	-19,5	-11,1	-11,1	4,2	4,2	11,1	-11,1				EF73E517F
22	07/01/2015 12:41	-27,6	-19,5	-11,1	-11,1	4,1	4,1	11,1	-11,1				E5428EF05
23	07/01/2015 12:42	-27,6	-19,5	-11,1	-11,1	4,2	4,2	11,1	-11,1			AUX3 DISABLED	E10B24EF7
24	07/01/2015 12:43	-27,6	-19,5	-11,0	-11,0	3,8	3,8	11,0	-11,0	3,8			EF73E517F
25	07/01/2015 12:44	-27,6	-19,5	-11,0	-11,0	4,2	4,2	11,0	-11,0	4,2			E10B24EF7
26	07/01/2015 12:45	-27,7	-19,5	-11,0	-11,0	4,2	4,2	11,0	-11,0	4,2			EF73E517F
27	07/01/2015 12:46	-27,6	-19,5	-11,0	-11,0	4,2	4,2	11,0	-11,0	4,2			E5428EF05
28	07/01/2015 12:47	-27,7	-19,5	-11,0	-11,0	4,2	4,2	11,0	-11,0	4,2			E10B24EF7
29	07/01/2015 12:48	-27,6	-19,5	-11,0	-11,0	4,2	4,2	11,0	-11,0	4,2			EF73E517F
30	07/01/2015 12:49	-27,6	-19,5	-11,0	-11,0	4,2	4,2	11,0	-11,0	4,2			E5428EF05

11.3.2 Activating the "service" writing mode

To activate the "service" writing mode, operate as follows:

1. Make sure the keyboard is not locked and no procedure is in progress.
2. Press and hold the "DOWN" key 1 s: the display will show the first available label.
3. Press and release the "UP" key or the "DOWN" key to select "**SEr**".
4. Press and release the "SET" key.
5. Press and release the "UP" key in 15 s to set "**1**".
6. Press and release the "SET" key or do not operate 15 s: the display will show "**SEr**" flashing 4 s, after which the device will quit the procedure.

11.4 Nomenclature of files

The following chart shows the meaning of the nomenclature of files written with "HACCP" writing mode and generated daily (for example the file "**log001_2015_03_26.csv**").

PART	MEANING
001	the device address (or parameter LA) has value 1
2015	the file has been generated on 2015
03	the file has been generated on March
26	the file has been generated day 26

The following chart shows the meaning of the nomenclature of files written with "HACCP" writing mode and generated monthly (for example the file "**log001_2015_m03.csv**").

PART	MEANING
001	the device address (or parameter LA) has value 1
2015	the file has been generated on 2015
m09	the file has been generated on March

The following chart shows the meaning of the nomenclature of files written with "service" writing mode (for example the file "**log001_2015_0001.csv**").

PART	MEANING
001	the device address (or parameter LA) has value 1
2015	the file has been generated on 2015
0001	progressiv NUMBER

11.5 Showing the errors about the data logging extension

To show the errors about the data logging extension, operate as follows:

1. Make sure the keyboard is not locked and no procedure is in progress.
2. Press and hold the "DOWN" key 1 s: the display will show the first available label.
3. Press and release the "UP" key or the "DOWN" key to select "**Err**".
4. Press and release the "SET" key.

If the device has no error in its memory, the label "**Err**" will not be shown.

5. Press and release the "UP" key or the "DOWN" key to show the error code.

The following chart shows the meaning of the error codes.

CODE	ERROR
FUL	SD card space run out
Sd	SD card non inserita o non riconosciuta
Pr7	auxiliary 2 probe error
Pr8	auxiliary 3 probe error
BAt	data logger battery error

To quit the procedure:

6. Press and release the "ON/STAND-BY" key.

12 COMPRESSOR OPERATING HOURS COUNT

12.1 Preliminary notes

The device can memorise up to 999 comp. operating hours.

The parameter C10 establishes the number of operating hours is higher than the limit at which the need for maintenance is signalled.

12.2 Display of Compressor Operation Hours

To display the compressor operation hours, proceed as follows:

1. Make sure that the keyboard is not locked and that no procedure is in progress.
2. Hold the key "DOWN" for 1 s: the display will show the first label available.
3. Press and release the "UP" or "DOWN" key to select a label.

The following table shows the correspondence between the labels and the relevant meaning.

LABEL	MEANING
CH1	Compressor operation Hours
CH2	Compressor 2 operation Hours

4. Press and release the "SET" key.

To exit the procedure:

5. Press and release the "SET" key or do not operate for 60 sec.
6. Press and release the "UP" or "DOWN" key until the display shows the magnitude established with parameter P5 or do not operate for 60 sec.

Alternatively:

7. Press and release the "ON/STAND-BY" key.

If the compressor 2 is not present (or if the u1 and/or u11 parameter is not set to 7), the "CH2" label shall not be displayed.

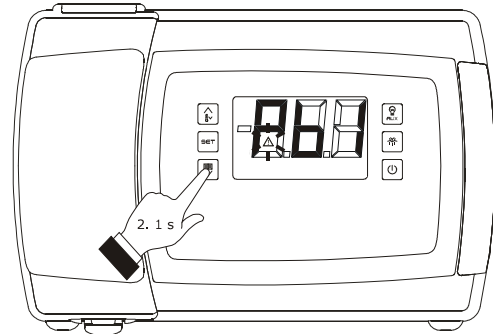

Access the procedure to display the compressor operation hours

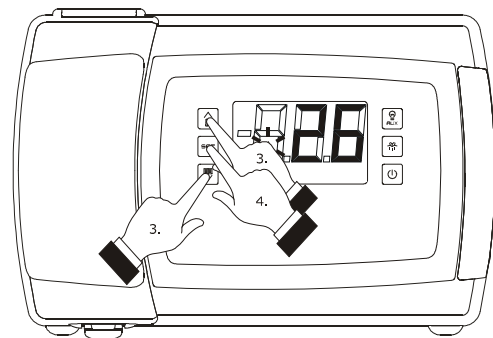

Display the compressor operation hours

12.3 Cancelling the compressor operation hours

To cancel the compressor operation hours, proceed as follows:

1. Make sure that the keyboard is not locked and that no procedure is in progress.
2. Hold the key "DOWN" for 1 s: the display will show the first label available.
3. Press and release the "UP" or "DOWN" key to select "rCH".
4. Press and release the "SET" key.
5. Press and release the "UP" or "DOWN" key within 15 s to set "149".
6. Press and release the "SET" or do not operate for 15 sec: the display will show a flashing "--" for 4 sec and the "alarm" LED switches off, after which the device will exit the procedure.

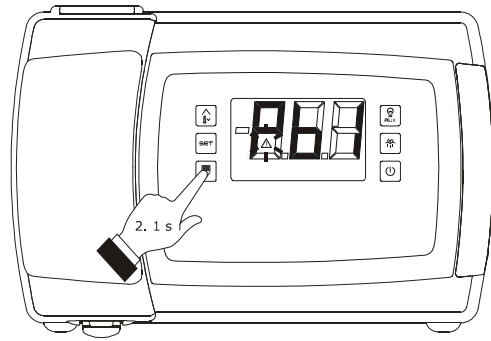

Access the procedure to cancel the compressor operation hours

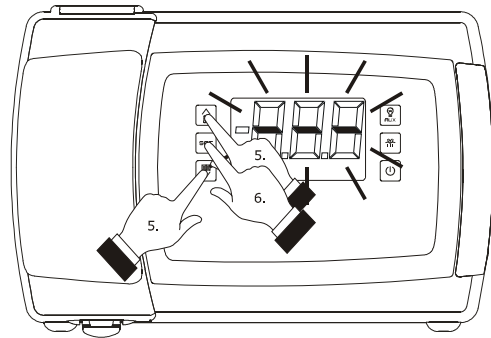

Cancelling the compressor operation hours

13 SETTINGS

13.1 Setting the date, time and day of the week (only in the models with clock)

The date can be set in the day-month-year format; the time in the hours-minutes format (24 h).

To access the procedure:

1. Make sure that the keyboard is not locked and that no procedure is in progress.
2. Hold the key "DOWN" for 1 s: the display will show the first label available.
3. Press and release the "UP" or "DOWN" key to select "rtc".

To set the year:

4. Press and release the "SET" key: the display will show "y" followed by the last two numbers of the year and the "clock" LED light shall flash.
5. Press and release the "UP" or "DOWN" key within 15 sec.

To set the month:

6. Press and release the "SET" key when setting the year: the display will show "n" followed by the number of the month.
7. Press and release the "UP" or "DOWN" key within 15 sec.

To set the day:

8. Press and release the "SET" key when setting the month: the display will show "d" followed by the number of the day.
9. Press and release the "UP" or "DOWN" key within 15 sec.

To set the hour:

10. Press and release the "SET" key when setting the day: the display will show "h" followed by the number of the hour.
11. Press and release the "UP" or "DOWN" key within 15 sec.

To set the minute:

12. Press and release the "SET" key when setting the hour: the display will show "n" followed by the number of the minute.
13. Press and release the "UP" or "DOWN" key within 15 sec.

To set the day of the week:

14. Press and release the "SET" key when setting the minute: the display will show the first label available.

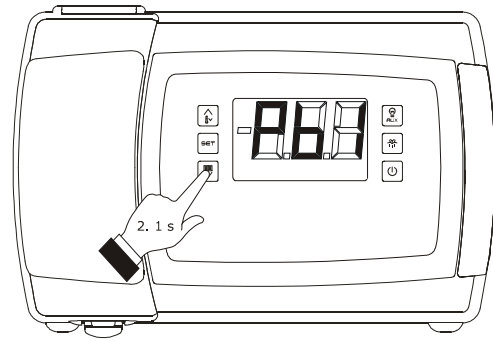

Access the procedure for setting the date, time and day of the week

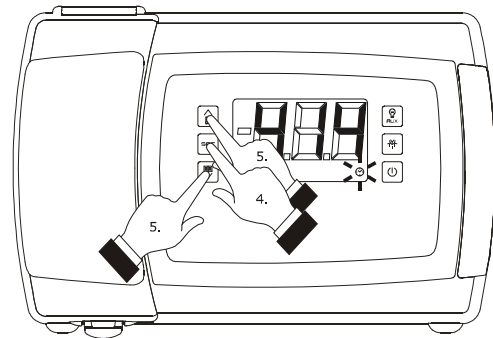

Setting the year

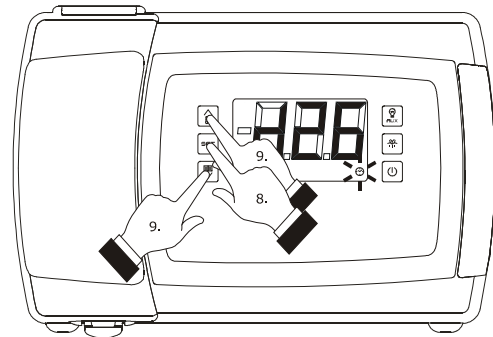

Setting the day

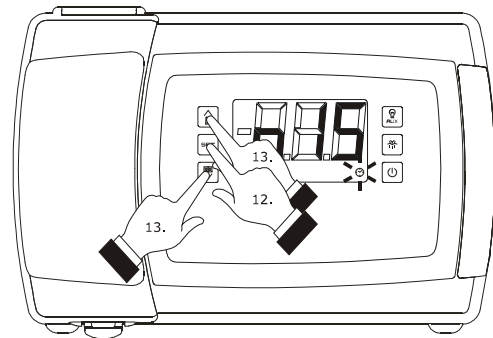

Setting the minute

15. Press and release the key or the key within 15 sec to set:
- "Mon" (Monday)
 - "tuE" (Tuesday)
 - "UEd" (Wednesday)
 - "thu" (Thursday)
 - "Fri" (Friday)
 - "SAT" (Saturday)
 - "Sun" (Sunday).
16. Press and release the "SET": the "clock" LED shall turn off, and then the device shall exit the procedure.

To exit the procedure before the operation is complete:

17. Do not operate for 60 sec (any changes will be saved).

13.2 Setting the working set point

To set the working set point, proceed as follows:

1. Make sure that the keyboard is not locked and that no procedure is in progress.
2. Press and release the "SET" key: the "compressor" LED will flash.
3. Press and release the "UP" or "DOWN" key within 15 sec; see also parameters r1, r2 and r3.
4. Press and release the "SET" key or do not operate for 15 sec: the "compressor" LED will switch off after which, the device will exit the procedure.

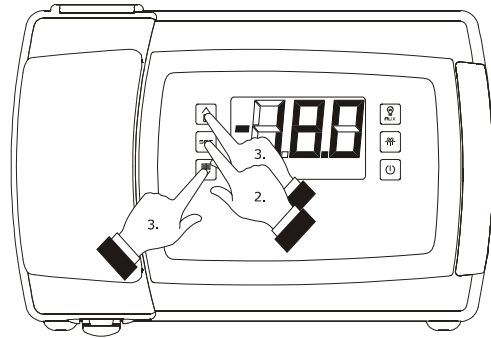

Setting the working set point

To exit the procedure before the operation is complete:

5. Do not operate for 15 sec (any changes will be saved).

The working set point can also be set via parameter SP.

13.3 Setting the configuration parameters

To access the procedure:

1. Make sure no procedures are in progress.
2. Hold the "UP" and "DOWN" key for 4 s: the display will show "PA".
3. Press and release the "SET" key.
4. Press and release the "UP" or "DOWN" key within 15 s to set "-19".
5. Press and release the "SET" key and do not operate for 15 s.
6. Hold the "UP" and "DOWN" key for 4 s: the display will show "SP".

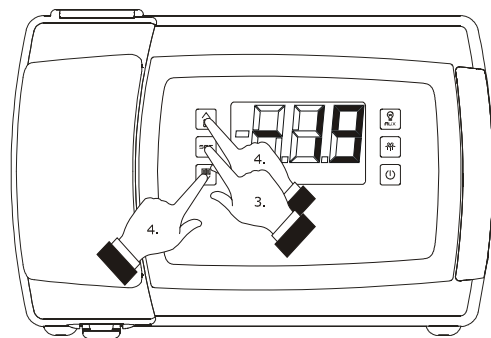

Access the procedure to set the configuration parameters

To select a parameter:

7. Press and release the "UP" key or the "DOWN" key.

To set a parameter:

8. Press and release the "SET" key.
9. Press and release the "UP" or "DOWN" key within 15 sec.
10. Press and release the "SET" key and do not operate for 15 s.

To exit the procedure:

11. Press and release the "UP" and "DOWN" key for 4 s or do not operate for 60 s (any changes will be saved).

After setting the parameters, suspend power supply flow to the device.

13.4 Restoring the Manufacturer's settings

To restore the manufacturer's settings, proceed as follows:

1. Make sure no procedures are in progress.
2. Hold the "UP" and "DOWN" key for 4 s: the display will show "PA".
3. Press and release the "SET" key.
4. Press and release the "UP" or "DOWN" key within 15 s to set "149".
5. Press and release the "SET" key and do not operate for 15 s.
6. Hold the "UP" and "DOWN" key for 4 s: the display will show "dEF".
7. Press and release the "SET" key.
8. Press and release the "UP" or "DOWN" key within 15 s to set "1".
9. Press and release the "SET" or do not operate for 15 sec: the display will show a flashing "dEF" for 4 sec, after which the device will exit the procedure
10. Cut the device power supply off.

To exit the procedure in advance:

11. Hold the "UP" and "DOWN" key for 4 s during the procedure (i.e. before setting "1": Restore will not be performed).

Make sure that the manufacturer's settings are appropriate (see paragraph 13.5 "List of configuration parameters").

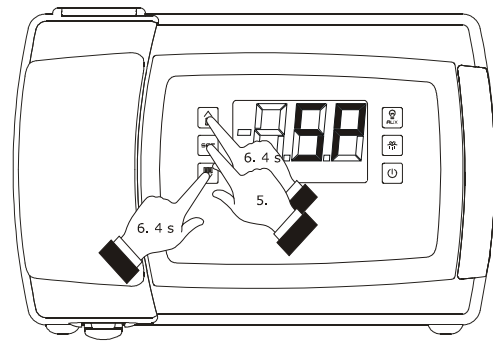

Access the procedure to set the configuration parameters

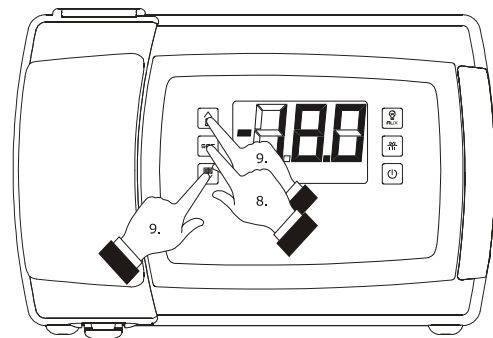

Setting a parameter

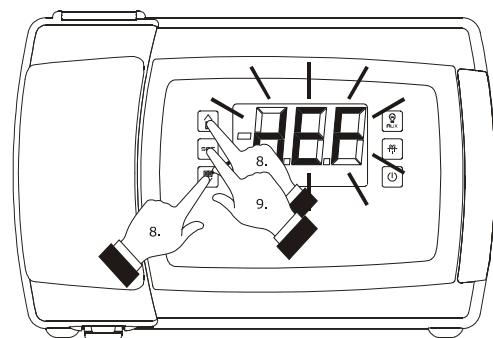

Restoring the Manufacturer's Settings

13.5 List of configuration parameters

The following table shows the meaning of the configuration parameters of the devices.

PARAM.	MIN.	MAX.	M.U.	EVB1204	EVB1214	EVB1206	EVB1216	EVB1226	EVB1236	EVB1246	EVB1256	WORKING SETPOINT
SP	r1	r2	°C/°F (1)	-18.0	-18.0	-18.0	-18.0	-18.0	-18.0	-18.0	-18.0	Working set-point; see also r0
PARAM.	MIN.	MAX.	M.U.	EVB1204	EVB1214	EVB1206	EVB1216	EVB1226	EVB1236	EVB1246	EVB1256	MEASUREMENT INPUTS
CA1	-25.0	25.0	°C/°F (1)	0.0	0.0	0.0	0.0	0.0	0.0	0.0	0.0	if P4 = 0, 1, 2 o 3, room temperature offset if P4 = 4, inlet air temperature offset
CA2	-25.0	25.0	°C/°F (1)	0.0	0.0	0.0	0.0	0.0	0.0	0.0	0.0	evaporator temperature offset
CA3	-25.0	25.0	°C/°F (1)	0.0	0.0	0.0	0.0	0.0	0.0	0.0	0.0	auxiliary temperature offset (see P4)
CA4	-25.0	25.0	°C/°F (1)	not avail.	not avail.	not avail.	not avail.	not avail.	not avail.	0.0	0.0	evaporation temperature offset
CA5	-25.0	25.0	points/10 (4)	not avail.	not avail.	not avail.	not avail.	not avail.	not avail.	0	0	vapour pressure offset
P0	0	2	----	1	1	1	1	1	1	1	1	temperature probe type; also look at Sd6 0 = PTC 1 = NTC 2 = Pt 1000

P1	0	1	-----	1	1	1	1	1	1	1	1	1	degree Celsius decimal point 1 = YES
P2	0	1	-----	0	0	0	0	0	0	0	0	0	temperature unit of measurement (2) 0 = degree Celsius 1 = degree Fahrenheit
P3	0	2	-----	1	1	1	1	1	1	1	1	1	evaporator temperature probe function 0 = probe absent 1 = defrosting probe and probe for evaporator fan thermostating 2 = probe for evaporator fan thermostating
P4	0	4	-----	3	3	3	3	3	3	3	3	3	magnitude recorded by the auxiliary temperature probe 0 = probe absent 1 = condenser temperature 2 = critical temperature 3 = evaporator 2 temperature 4 = outlet air temperature; in this case the temperature associated with the setting shall be the CPT (Calculated Product Temperature) one; see also P7
P5	0	4	-----	0	0	0	0	0	0	0	0	0	magnitude displayed during normal operation 0 = if P4 = 0, 1, 2 or 3, room temperature if P4 = 4, CPT temperature 1 = working set-point 2 = evaporator temperature 3 = temperature recorded by the auxiliary probe (see P4) 4 = inlet air temperature (only if P4 = 4)

P7	0	100	%	50	50	50	50	50	50	50	50	percentage of the temperature detected by the inlet air for the calculation of the CPT temperature (only if P4 = 4) (3)
P8	0	250	s/10	5	5	5	5	5	5	5	5	delay displaying temperature variation
P9	-99.9	99.9	bar g / PSI g	not avail.	not avail.	not avail.	not avail.	not avail.	not avail.	-0.5	-0.5	pressure transducer minimum setting
P10	-99.9	99.9	bar g / PSI g	not avail.	not avail.	not avail.	not avail.	not avail.	not avail.	7.0	7.0	pressure transducer maximum setting
PARAM.	MIN.	MAX.	M.U.	EVB1204	EVB1214	EVB1206	EVB1216	EVB1226	EVB1236	EVB1246	EVB1256	MAIN REGULATOR
r0	0,1 (5)	15.0	°C/°F (1)	2.0	2.0	2.0	2.0	2.0	2.0	2.0	2.0	if u1 and/or u11 = 7, working set-point differential; see also r12 (6) if u1 and/or u11 = 7, proportional band; see also r12 (7)
r1	-99.0	r2	°C/°F (1)	-50.0	-50.0	-50.0	-50.0	-50.0	-50.0	-50.0	-50.0	minimum working set-point
r2	r1	99.0	°C/°F (1)	50.0	50.0	50.0	50.0	50.0	50.0	50.0	50.0	maximum working set-point
r3	0	1	----	0	0	0	0	0	0	0	0	locking of working set-point setting (using the procedure described in paragraph "Setting the working set point") 1 = YES

r4	0.0	99.0	°C/°F (1)	0.0	0.0	0.0	0.0	0.0	0.0	0.0	0.0	working set point increase during the "energy saving" function; see also i5, i10, i15, H01... H14
r5	0.0	99.0	°C/°F (1)	0.0	0.0	0.0	0.0	0.0	0.0	0.0	0.0	working set-point decrease during the "rapid cooling" function; see also r6
r6	0	240	min	30	30	30	30	30	30	30	30	duration of "rapid cooling" function; see also r5
r12	0	1	-----	1	1	1	1	1	1	1	1	type of r0 0 = asymmetric 1 = symmetric
PARAM.	MIN.	MAX.	M.U.	EVB1204	EVB1214	EVB1206	EVB1216	EVB1226	EVB1236	EVB1246	EVB1256	ELECTRONIC EXPANSION VALVE (45)
h01	3.0	25.0	°C/°F (1)	not avail.	not avail.	not avail.	not avail.	not avail.	not avail.	6.0	6.0	superheating
h02	10.0	40.0	°C/°F (1)	not avail.	not avail.	not avail.	not avail.	not avail.	not avail.	15.0	15.0	evaporating temperature above which the high superheating alarm is activated (code " HS H") (11)
h03	-70.0	40.0	°C/°F (1)	not avail.	not avail.	not avail.	not avail.	not avail.	non disp.	-70.0	-70.0	evaporating temperature below which the low pressure modality is activated (the valve is completely open; code " LO P") (11)
h04	1.0	99.9	°C/°F (1)	not avail.	not avail.	not avail.	not avail.	not avail.	not avail.	50.0	50.0	PID action proportional band
h05	0	999	s	not avail.	not avail.	not avail.	not avail.	not avail.	not avail.	50	50	PID action integral time

h06	0	999	s	not avail.	not avail.	not avail.	not avail.	not avail.	not avail.	10	10	PID action derivative time
h07	1	250	s	not avail.	not avail.	not avail.	not avail.	not avail.	not avail.	30	30	starting delay
h08	-1	100	%	not avail.	not avail.	not avail.	not avail.	not avail.	not avail.	-1	-1	percentage valve open during the manual operation -1 = the superheating will be enabled
h09	0	100	%	not avail.	not avail.	not avail.	not avail.	not avail.	not avail.	0	0	percentage valve open during the hot gas defrost (during the pre-dripping and the dripping the valve will be closed, during the evaporator fan delay the valve opening will be function of the algorithm of regulation)
h10	0	45.0	bar g / PSI g (4)	not avail.	not avail.	not avail.	not avail.	not avail.	not avail.	1.0	1.0	evaporating pressure below which the compressor is switched off during the pump down
h11	0	250	min	not avail.	not avail.	not avail.	not avail.	not avail.	not avail.	3	3	high superheating alarm delay (code "HSH") and operative low pressure alarm delay (code "LOP")
h12	0	1	----	not avail.	not avail.	non disp.	non disp.	non disp.	non disp.	0	0	enabling the low pressure alarm (code "LP") 1 = YES
h13	-0.5	45.0	bar g / PSI g (4)	not avail.	not avail.	not avail.	not avail.	not avail.	not avail.	0.5	0.5	evaporating pressure below which the lower pressure alarm is activated (code "LP") (44)
h14	0	250	min	not avail.	not avail.	not avail.	not avail.	not avail.	not avail.	3	3	low pressure alarm delay (code "LP")

h15	0	7	----	not avail.	not avail.	not avail.	not avail.	not avail.	not avail.	2	2	kind of refrigerat gas 0 = R-22 1 = R-404A 2 = R-507A 3 = R-744 4 = R-290 5 = R-717 6 = R1270 7 = R-407F
h16	0	2	----	not avail.	not avail.	not avail.	not avail.	not avail.	not avail.	1	1	kind of electronic expansion valve 0 = generic valve 1 = Sanhua DPF 2 = Danfoss ETS 6
h17	0	100	%	not avail.	not avail.	not avail.	not avail.	not avail.	not avail.	30	30	percentage valve open during the evaporating pressure probe error (code "Pr4") and/or during the evaporating temperature probe error (code "Pr5")
h18	0	490	steps x 10 (43)	not avail.	not avail.	not avail.	not avail.	not avail.	not avail.	100	100	maximum number of operative steps of the generic electronic expansion valve
h19	0	250	steps (43)	not avail.	not avail.	not avail.	not avail.	not avail.	not avail.	30	30	number of overdriving steps of the generic electronic expansion valve
h20	25	999	steps/s	not avail.	not avail.	not avail.	not avail.	not avail.	not avail.	100	100	step frequency of the generic electronic expansion valve
PARAM.	MIN.	MAX.	M.U.	EVB1204	EVB1214	EVB1206	EVB1216	EVB1226	EVB1236	EVB1246	EVB1256	COMPRESSOR PROTECTION SYSTEM

C0	0	240	min	0	0	0	0	0	0	0	0	0	delay in switching on of compressor after the device switches on (8)
C1	0	240	min	5	5	5	5	5	5	5	5	5	minimum time between two consecutive compressor start-ups; also delay in compressor start-up after conclusion of room temperature/inlet air probe error (code " Pr1 ") (9) (10)
C2	0	240	min	3	3	3	3	3	3	3	3	3	minimum compressor switch-off duration (9)
C3	0	240	s	0	0	0	0	0	0	0	0	0	minimum duration of compressor switch on time
C4	0	240	min	10	10	10	10	10	10	10	10	10	duration of compressor switch off time during a room temperature/inlet air probe error (code " Pr1 "); see also C5
C5	0	240	min	10	10	10	10	10	10	10	10	10	duration of compressor switch on time during a room temperature/inlet air probe error (code " Pr1 "); see also C6
C6	0.0	199	°C/°F (1)	80.0	80.0	80.0	80.0	80.0	80.0	80.0	80.0	80.0	condenser temperature is higher than that at which the condenser overheating alarm is activated (code " COH ") (11)
C7	0.0	199	°C/°F (1)	90.0	90.0	90.0	90.0	90.0	90.0	90.0	90.0	90.0	condenser temperature above which the blocked compressor alarm is activated (code " CSd ")
C8	0	15	min	1	1	1	1	1	1	1	1	1	blocked compressor alarm delay (code " CSd ") (12)

C10	0	999	hx10	0	0	0	0	0	0	0	0	number of operating hours is higher than the limit at which the need for maintenance is signalled 0 = function absent
C11	0	240	s	3	3	3	3	3	3	3	3	minimum time interval between the switching on of two different compressors (only if u1 and/or u11 = 7)
C12	0	10	----	2	2	2	2	2	2	2	2	incidence of the number of compressor operation hours on the choice of compressor to be switched on/off when attempting to balance the number of operation hours and the number of switch-ons of the two compressors ; see also C13 (only if u1 and/or u11 = 7)
C13	0	10	----	1	1	1	1	1	1	1	1	incidence of the switch-ons of the compressor on the choice of compressor to be switched on/off when attempting to balance the number of operation hours and the number of switch-ons of the two compressors ; see also C12 (only if u1 and/or u11 = 7)

C14	0	2	----	0	0	0	0	0	0	0	2	2	<p>type of pump down</p> <p>0 = <u>TIMED</u> - the compressor and the pump down valve (or the electronic expansion valve if present) shall be switched on at the same time due to the setting; the pump down valve (or the electronic expansion valve if present) shall be turned off due to the setting and the compressor after the expiration of the u3 time interval from the valve switch-off (only if u1 and/or u11 = 10)</p> <p>1 = <u>FROM DIGITAL INPUT</u> - the compressor and the pump down valve (or the electronic expansion valve if present) shall be switched on at the same time due to the setting; the pump down valve shall be turned off due to the setting and the compressor afterwards and as a consequence of the activation of the multifunction or multifunction 2 input (only if i5 or i15 = 6); see also u3 (only if u1 and/or u11 = 10)</p> <p>2 = <u>FOR EVAPORATING PRESSURE</u> - (ONLY AVAILABLE IN MODELS EVB1246 and EVB1256) - the electronic expansion valve (it will also work as pump down valve) will be switched-on due to the setting and the compressor on afterwards; the electronic expansion valve will be switched off due to the setting and the compressor on afterwards and as a consequence of the attainment by the evaporating pressure of the value set with parameter h10; see also u3</p>
-----	---	---	------	---	---	---	---	---	---	---	---	---	---

PARAM.	MIN.	MAX.	M.U.	EVB1204	EVB1214	EVB1206	EVB1216	EVB1226	EVB1236	EVB1246	EVB1256	DEFROSTING
d0	0	99	h	8	8	8	8	8	8	8	8	if d8 = 0, 1 or 2, defrosting interval (13) 0 = interval defrosting will never be activated d8 = 3, maximum defrost interval
d1	0	2	-----	0	0	0	0	0	0	0	0	type of defrosting 0 = <u>ELECTRIC</u> - during defrosting the compressor will remain off and the defrosting output will be activated; evaporator fan activity will depend on parameter F2 1 = <u>BY HOT GAS</u> - during defrosting the compressor will be switched on and the defrosting output will be activated; evaporator fan activity will depend on parameter F2 2 = <u>VIA STOPPING OF COMPRESSOR</u> - during defrosting the compressor will remain switched off and the defrosting output will remain deactivated; evaporator fan activity will depend on parameter F2
d2	-99	99.0	°C/°F (1)	3,0	3,0	3,0	3,0	3,0	3,0	3,0	3,0	temperature at end of defrosting (only if P3 = 1); see also d3
d3	0	99	min	30	30	30	30	30	30	30	30	if P3 = 0 o 2, defrosting duration se P3 = 1, maximum defrosting duration; see also d2 0 = defrosting will not be activated

d4	0	1	----	0	0	0	0	0	0	0	0	defrosting when device is switched on (only if d8 = 0, 1, 2 or 3) (8) 1 = YES
d5	0	99	min	0	0	0	0	0	0	0	0	if d4 = 0, minimum time between switching on of device and activation of defrosting (8) if d4 = 1, delay in activation of defrosting after device is switched on (8)
d6	0	2	----	1	1	1	1	1	1	1	1	temperature displayed during defrosting (only if P5 = 0) 0 = room temperature or CPT temperature 1 = if on activation of defrosting, the room temperature or CPT temperature is below the "work set point + t", at maximum " work set point + t"; if on activation of defrosting, the room temperature or CPT temperature is above "work set point + t", at maximum the room temperature or CPT temperature on activation of defrosting (14) (15) 2 = indication "DEF" (16)
d7	0	15	min	2	2	2	2	2	2	2	2	during dripping the compressor will remain switched off and the defrosting output will remain deactivated; if d16 = 0, evaporator fan activity will depend on parameter F2; if d16 0, the evaporator fan will remain switched off)

d8	0	4	----	0	0	0	0	0	0	0	0	<p>defrosting activation methods</p> <p>0 = <u>AT INTERVALS</u> - defrosting will be activated once the device has altogether been running for time d0</p> <p>1 = <u>AT INTERVALS - FOR COMPRESSOR SWITCH-ON</u> - defrosting will be activated once the compressor has altogether been switched on for time d0</p> <p>2 = <u>AT INTERVALS - FOR EVAPORATOR TEMPERATURE</u> - defrosting will be activated when the evaporator temperature has remained below the temperature d9 for a total time of d0 (17)</p> <p>3 = <u>ADAPTABLE</u> - defrosting will be activated at intervals, whose duration will each time depend on the duration of compressor switch-ons and the evaporator temperature; see also d18, d19, d20 and d22 (17)</p> <p>4 = <u>IN REAL TIME</u> - defrosting will be activated at the times established in parameters Hd1... Hd6 (not visible in models EVB1204, EVB1206, EVB1226 and EVB1246)</p>
d9	-99	99.0	°C/°F (1)	0.0	0.0	0.0	0.0	0.0	0.0	0.0	0.0	<p>evaporator temperature is higher than that at which the defrost interval counter is suspended (only if d8 = 2)</p>
d11	0	1	----	0	0	0	0	0	0	0	0	<p>defrosting alarm switches off once maximum time limit has been reached (code "dFd"; only if P3 = 1 and in absence of an evaporator temperature probe (code "Pr2")</p> <p>1 = YES</p>

d15	0	99	min	0	0	0	0	0	0	0	0	0	minimum time that the compressor must be switched on before defrosting can be activated (only if d1 = 1) (18)
d16	0	99	min	0	0	0	0	0	0	0	0	0	predripping duration (during predripping the compressor will remain switched off, the defrosting output will be activated and the evaporator fan will remain switched off)
d18	0	999	min	40	40	40	40	40	40	40	40	40	defrosting interval (only if d8 = 3; defrosting will be activated when the compressor has been on totally, with the evaporator temperature below that of d22, for time d18) 0 = defrosting will never be activated due to the effect of this condition
d19	0.0	40.0	°C/°F (1)	3.0	3.0	3.0	3.0	3.0	3.0	3.0	3.0	3.0	evaporator temperature above which the defrost is activated (relative to the evaporator temperatures average, or "evaporator temperatures average - d19") (only if d8 = 3)
d20	0	500	min	180	180	180	180	180	180	180	180	180	minimum consecutive time the compressor must be switched on such as to provoke the defrost activation 0 = defrosting will never be activated due to the effect of this condition

d21	0	500	min	200	200	200	200	200	200	200	200	<p>minimum consecutive time the compressor must be switched on after the instrument switches on (on condition that the difference "cell temperature - working setpoint" is higher than 10 °C/20 °F) and after function Overcooling is activated such as to provoke the defrost activation</p> <p>0 = the defrost will never be activated because the compressor has been switched on</p>
d22	0.0	10.0	°C/°F (1)	2.0	2.0	2.0	2.0	2.0	2.0	2.0	2.0	<p>evaporator temperature above which the time d18 count is paused (relating to the average of evaporator temperatures, that is to say, "evaporator temperatures average + d22") (only if d8 = 3)</p>
d25	0	1	-----	0	0	0	0	0	0	0	0	<p>enabling of the outlet air temperature probe as defrosting probe during the evaporator temperature probe error (code "Pr2"; only if P4 = 4); see also d26 (19)</p>
d26	0	99	h	6	6	6	6	6	6	6	6	<p>defrosting interval for effect of enabling of outlet air temperature probe like defrosting probe during evaporator temperature probe error (code "Pr2"; only if P4 = 4), if d25 = 1 (13)</p> <p>0 = defrosting will never be activated due to the effect of this condition</p>

PARAM.	MIN.	MAX.	M.U.	EVB1204	EVB1214	EVB1206	EVB1216	EVB1226	EVB1236	EVB1246	EVB1256	TEMPERATURE ALARMS
A0	0	1	----	0	0	0	0	0	0	0	0	temperature associated with the minimum temperature alarm (code "AL") 0 = room temperature or CPT temperature 1 = evaporator temperature (20)
A1	-99.0	99.0	°C/°F (1)	-10.0	-10.0	-10.0	-10.0	-10.0	-10.0	-10.0	-10.0	temperature below that at which the minimum temperature alarm is activated (code "AL"); see also A0, A2 and A11
A2	0	2	----	0	0	0	0	0	0	0	0	type of minimum temperature alarm (code "AL") 0 = alarm absent 1 = relative to working set-point (that is "working set-point - A1"; consider A1 without sign) 2 = absolute (that is A1)
A4	-99.0	99.0	°C/°F (1)	10,0	10,0	10,0	10,0	10,0	10,0	10,0	10,0	temperature higher than that at which the maximum temperature alarm is activated (code "AH"); see also A5 and A11
A5	0	2	----	0	0	0	0	0	0	0	0	type of maximum temperature alarm (code "AH") 0 = alarm absent 1 = relative to working set-point (that is "working set-point + A4"; consider A1 without sign) 2 = absolute (that is A4)
A6	0	240	min	120	120	120	120	120	120	120	120	delay in maximum temperature alarm (code "AH") after the device is switched on (8)

A7	0	240	min	15	15	15	15	15	15	15	15	temperature alarm delay (code "AL" and code "AH")
A8	0	240	min	15	15	15	15	15	15	15	15	delay in maximum temperature alarm (code "AH") from the conclusion of evaporator fan standstill (21)
A9	0	240	min	15	15	15	15	15	15	15	15	delay in maximum temperature alarm (code "AH") following the deactivation of the door micro switch input (22)
A10	0	240	min		1	not avail.	1	not avail.	1	not avail.	1	duration of a power cut such to cause the power cut alarm to be memorised (code "PF")
A11	0.1 (5)	15.0	°C/°F (1)	2.0	2.0	2.0	2.0	2.0	2.0	2.0	2.0	differential of parameters A1 and A4
A12	0	2	----	not avail.	1	not avail.	1	not avail.	1	not avail.	1	type of power supply cut-off alarm signal (code "PF") 0 = alarm will be signalled by the "HACCP" LED 1 = alarm will be signalled by the "PF" code, the buzzer and the "HACCP" LED 2 = alarm will be signalled by the "PF" code, buzzer (as long as cut-off duration exceeds time A10) and by the "HACCP" LED

PARAM.	MIN.	MAX.	M.U.	EVB1204	EVB1214	EVB1206	EVB1216	EVB1226	EVB1236	EVB1246	EVB1256	EVAPORATOR FAN AND CONDENSER FAN
F0	0	5	----	1	1	1	1	1	1	1	1	evaporator fan activity during normal operation 0 = switched off 1 = switched on; see also F13, F14 and i10 (23) 2 = in parallel with the compressor; see also F9, F13, F14 and i10 (24) 3 = depending on F1; see also F9, F13, F14 and i10 (25) (26) 4 = switched off if the compressor is switched off, dependent on F1 if the compressor is switched on; see also F9, F13, F14 and i10 (25) (27) 5 = depending on F6; see also F9
F1	-99.0	99.0	°C/°F (1)	-1.0	-1.0	-1.0	-1.0	-1.0	-1.0	-1.0	-1.0	evaporator temperature above the limit at which the evaporator fan is switched off (only if F0 = 3 o 4); see also F8
F2	0	2	----	0	0	0	0	0	0	0	0	evaporator fan activity during defrosting and dripping 0 = switched off 1 = switched on (setting parameter d7 to 0 is recommended) 2 = depending on F0

F3	0	15	min	0	0	0	0	0	0	0	0	maximum duration of evaporator fan deactivation; see also F7 (during evaporator fan deactivation the compressor can be switched on, the defrosting output will remain deactivated and the evaporator fan will remain switched off)
F4	0	240	s	60	60	60	60	60	60	60	60	duration of evaporator fan deactivation during operation in low relative humidity conditions with the compressor switched off; see also F5 (only if F0 = 5)
F5	0	240	s	10	10	10	10	10	10	10	10	duration of evaporator fan activation during operation in low relative humidity conditions with the compressor switched off; see also F4 (only if F0 = 5)
F6	0	1	----	0	0	0	0	0	0	0	0	operation in low or high relative humidity conditions (only if F0 = 5) (28) 0 = low relative humidity (during operation in low relative humidity conditions the evaporator fan shall function in parallel with the compressor; see also F4 and F5) 1 = high relative humidity (during operation in high relative humidity conditions the evaporator fan shall be switched on)
F7	-99.0	99.0	°C/°F (1)	5.0	5.0	5.0	5.0	5.0	5.0	5.0	5.0	evaporator temperature below which the evaporator fan is restarted (in respect to the working set point, that is to say "working set-point + F7"); see also F3

F8	0.1 (5)	15.0	°C/°F (1)	2.0	2.0	2.0	2.0	2.0	2.0	2.0	2.0	F1 differential
F9	0	240	s	0	0	0	0	0	0	0	0	delay in the switching off of evaporator fan following the switching off of the compressor (only if F0 = 2, 4 and 5)
F11	0.0	99.0	°C/°F (1)	15.0	15.0	15.0	15.0	15.0	15.0	15.0	15.0	temperature of the condenser above which the condenser fan is switched on ("F11 + 2,0 °C/4 °F, only if u1 and/or u11 = 6) (29) (30)
F12	0	240	s	30	30	30	30	30	30	30	30	delay in the switching off of condenser fan following the switching off of the compressor (only if u1 and/or u11 = 6)
F13	0	240	sx10	30	30	30	30	30	30	30	30	duration of evaporator fan switch off during "energy saving" function, see also F14, i10, H01... H14 (only if F0 = 1, 2, 3 or 4)
F14	0	240	sx10	30	30	30	30	30	30	30	30	duration of evaporator fan switch on during "energy saving" function, see also F13, i10, H01... H14 (only if F0 = 1, 2, 3 or 4)

PARAM.	MIN.	MAX.	M.U.	EVB1204	EVB1214	EVB1206	EVB1216	EVB1226	EVB1236	EVB1246	EVB1256	DIGITAL INPUTS
i0	0	5	----	3	3	3	3	3	3	3	3	<p>effect caused by the activation of the door micro input; see also i4 (0 = no effect)</p> <p>1 = <u>SWITCH-OFF OF THE COMPRESSOR AND EVAPORATOR FAN</u> - the compressor and the evaporator fan will be switched off (at maximum for time i3 or until the input is deactivated) (31)</p> <p>2 = <u>SWITCH-OFF OF THE EVAPORATOR FAN</u> - the evaporator fan will be switched off (at maximum for time i3 or until the input is deactivated)</p> <p>3 = <u>SWITCH ON OF ROOM LIGHT</u> - the room light shall be switched on (in the EVB1204 and EVB1214 models only if u1 = 0; the light shall be switched off after 10 s from input deactivation)</p> <p>4 = <u>SWITCH-OFF OF THE COMPRESSOR AND EVAPORATOR FAN AND SWITCH ON OF ROOM LIGHT</u> - the compressor and the evaporator fan will be switched off (at maximum for time i3 or until the input is deactivated) and the room light shall be switched on (in the EVB1204 and EVB1214 models only if u1 = 0; the light shall be switched off after 10 s from input deactivation) (31)</p> <p>5 = <u>SWITCH-OFF OF THE EVAPORATOR FAN AND SWITCH ON OF ROOM LIGHT</u> - the evaporator fan will be switched off (at maximum for time i3 or until the input is deactivated) and the room light shall be switched on (in the EVB1204 and EVB1214 models only if u1 = 0; the light shall be switched off after 10 s from input deactivation)</p>

i1	0	1	-----	0	0	0	0	0	0	0	0	0	type of door micro switch input contact 0 = normally open (active input with closed contact) 1 = normally closed (active input with open contact)
i2	-1	120	min	30	30	30	30	30	30	30	30	30	delay in signalling of door micro switch input alarm (code "id") -1 = the alarm will not be signalled
i3	-1	120	min	15	15	15	15	15	15	15	15	15	maximum duration of the effect caused by the activation of the door micro switch input on the compressor and the evaporator
i4	0	1	-----	0	0	0	0	0	0	0	0	0	storage of door micro switch input alarm (code "id") (32) 1 = YES

i5	0	9	-----	7	7	7	7	7	7	7	7	<p>effect caused buy the activation of the multifunction input (33)</p> <p>0 = no effect</p> <p>1 = <u>ACTIVATION OF "ENERGY SAVING" FUNCTION</u> - the "energy saving" function will be activated (just with effect on the compressor, until the input is deactivated), provided the "rapid cooling" is not running; see also r4</p> <p>2 = <u>ACTIVATION OF MULTIFUNCTION INPUT ALARM</u> - once time i7 has passed the display will show the flashing code "iA" and the buzzer will be activated (until the input is deactivated)</p> <p>3 = <u>ACTIVATION OF THE MAXIMUM PRESSURE SWITCH ALARM</u> - the compressor will be switched off, the condenser fan will be switched on (only if u1 and/or u11 = 6), the display will show the flashing code "iA" and the buzzer will be activated (until the input is deactivated): when the input has been activated the number of times established with parameter i8 the regulators will be switched off, the condenser fan will be switched on (only if u1 and/or u11 = 6), the display will show the flashing code "iSd" and the buzzer will be activated (until the input is deactivated and the device is switched off and restarted or until the power supply is interrupted); see also i7 and i9</p> <p>4 = <u>SWITCHING ON THE AUXILIARY OUTPUT</u> - the auxiliary output will be switched on (only if u1 and/or u11 = 2, until the input is deactivated)</p> <p>5 = <u>SWITCHING OFF THE DEVICE</u> - the device will be switched off (until the input is deactivated)</p>
----	---	---	-------	---	---	---	---	---	---	---	---	---

i5	0	9	----	7	7	7	7	7	7	7	7	<p>6 = <u>ACTIVATION OF THE MINIMUM PRESSURE SWITCH ALARM</u> - the compressor will be switched off, the display will show the flashing code "LP" and the buzzer will be activated (until the input is deactivated); if u1 and/or u11 = 10, the compressor will be switched off after the pump down valve has switched off (also look at C14 and i17)</p> <p>7 = <u>COMPRESSOR THERMAL PROTECTION</u> - the compressor will be switched off, the display will show the flashing code "C1t" and the buzzer will be activated (until the input is deactivated)</p> <p>8 = <u>COMPRESSOR 2 THERMAL PROTECTION</u> - the compressor 2 will be switched off (only if u1 and/or u11 = 7), the display will show the flashing code "C2t" and the buzzer will be activated (until the input is deactivated)</p> <p>9 = <u>MAN IN COLD ROOM ALARM ACTIVATION</u> - the man in cold room output shall be turned on (only if u1 and/or u11 = 12), the display will show the flashing code "MiC" and the buzzer will be activated (until the input is deactivated)</p>
i6	0	1	----	0	0	0	0	0	0	0	0	<p>type of multifunction input contact</p> <p>0 = normally open (active input with closed contact)</p> <p>1 = normally closed (active input with open contact)</p>
i7	0	120	min	0	0	0	0	0	0	0	0	<p>if i5 and/or i15 = 2, multifunction input alarm delay (code "iA")</p> <p>if i5 and/or i15 = 3, delay in compressor switching on after the deactivation of the multifunction input (34)</p>

i8	0	15	-----	0	0	0	0	0	0	0	0	number of multifunction input alarms (code "iA") such to cause a pressure switch alarm (code "iSd") (only if i5 and/or i15 = 3) 0 = function disabled
i9	1	999	min	240	240	240	240	240	240	240	240	time that must pass in absence of multifunction input alarms (code "iA") so that the alarm counter is reset (only i5 and/or i15 = 3)
i10	0	999	min	0	0	0	0	0	0	0	0	time that must pass in absence of door micro switch input activations (after the room temperature or COT temperature has reached the working set-point) for the "energy saving" function to be activated (this impacts the evaporator fan only if F0 = 1, 2, 3 or 4); see also r4, HE2 and H01... H14 0 = the function will never be activated due to the effect of this condition
i13	0	240	-----	180	180	180	180	180	180	180	180	number of door switch input activations such as to provoke the defrost activation 0 = defrosting will never be activated due to the effect of this condition
i14	0	240	-----	32	32	32	32	32	32	32	32	minimum duration of the door switch input activation such as to provoke the defrost activation 0 = defrosting will never be activated due to the effect of this condition

i15	0	9	-----	9	9	9	9	9	9	9	9	<p>effect caused buy the activation of the multifunction input 2 (33)</p> <p>0 = no effect</p> <p>1 = <u>ACTIVATION OF "ENERGY SAVING" FUNCTION</u> - the "energy saving" function will be activated (just with effect on the compressor, until the input is deactivated), provided the "rapid cooling" function is not running; see also r4</p> <p>2 = <u>ACTIVATION OF MULTIFUNCTION INPUT ALARM</u> - once time i7 has passed the display will show the flashing code "iA" and the buzzer will be activated (until the input is deactivated)</p> <p>3 = <u>ACTIVATION OF THE MAXIMUM PRESSURE SWITCH ALARM</u> - the compressor will be switched off, the condenser fan will be switched on(only if u1 and/or u11 = 6), the display will show the flashing code "iA" and the buzzer will be activated (until the input is deactivated): when the input has been activated the number of times established with parameter i8 the regulators will be switched off, the condenser fan will be switched on (only if u1 and/or u11 = 6), the display will show the flashing code "iSd" and the buzzer will be activated (until the input is deactivated and the device is switched off and re-started or until the power supply is interrupted); see also i7 and i9</p> <p>4 = <u>SWITCHING ON THE AUXILIARY OUTPUT</u> - the auxiliary output will be switched on (only if u1 and/or u11 = 2, until the input is deactivated)</p> <p>5 = <u>SWITCHING OFF THE DEVICE</u> - the device will be switched off (until the input is deactivated)</p>
-----	---	---	-------	---	---	---	---	---	---	---	---	--

i15	0	9	-----	9	9	9	9	9	9	9	9	<p>6 = <u>ACTIVATION OF THE MINIMUM PRESSURE SWITCH ALARM</u> - the compressor will be switched off, the display will show the flashing code "LP" and the buzzer will be activated (until the input is deactivated); if u1 and/or u11 = 10, the compressor will be switched off after the switching off of the pump down valve (also look at C14 and i17)</p> <p>7 = <u>COMPRESSOR THERMAL PROTECTION</u> - the compressor will be switched off, the display will show the flashing code "C1t" and the buzzer will be activated (until the input is deactivated)</p> <p>8 = <u>COMPRESSOR 2 THERMAL PROTECTION</u> - the compressor will 2 be switched off (only if u1 and/or u11 = 7), the display will show the flashing code "C2t" and the buzzer will be activated (until the input is deactivated)</p> <p>9 = <u>MAN IN COLD ROOM ALARM ACTIVATION</u> - the man in cold room output shall be turned on (only if u1 and/or u11 = 12), the display will show the flashing code "MiC" and the buzzer will be activated (until the input is deactivated)</p>
i16	0	1	-----	0	0	0	0	0	0	0	0	<p>type of multifunction 2 input contact</p> <p>0 = normally open (active input with closed contact)</p> <p>1 = normally closed (active input with open contact)</p>
i17	0	240	s	30	30	30	30	30	30	30	30	<p>minimum pressure switch alarm delay after the compressor switches on (code "LP")</p>

PARAM.	MIN.	MAX.	M.U.	EVB1204	EVB1214	EVB1206	EVB1216	EVB1226	EVB1236	EVB1246	EVB1256	DIGITAL OUTPUTS
u1	0	12	----	0	0	not avail.	not avail.	not avail.	not avail.	not avail.	not avail.	operation controlled by digital output K4 (35) (36) 0 = <u>ROOM LIGHT</u> - in this case the "AUXILIARY" key and parameters i0 and u2 will be activated 1 = <u>DEMISTER HEATING ELEMENTS</u> - in this case the "AUXILIARY" key and parameter u6 will be activated 2 = <u>AUXILIARY OUTPUT</u> - in this case the "AUXILIARY" key and parameters i5, i15 and u2 will be activated 3 = <u>ALARM OUTPUTS</u> - in this case parameter u4 will be activated 4 = <u>DOOR HEATING ELEMENTS</u> - in this case parameter u5 will be activated 5 = <u>HEATING ELEMENTS FOR NEUTRAL AREA OPERATION</u> - in this case parameter u7 will be activated 6 = <u>CONDENSER FAN</u> - in this case parameters P4, F11 and F12 will be activated 7 = <u>COMPRESSOR 2</u> - in this case, parameters r0, r12, C11, C12 and C13 (37) will assume significance of 8 = <u>DEFROSTING 2</u> - in this case parameters P4 and d (38) will assume significance 9 = <u>EVAPORATOR FAN 2</u> - in this case parameters P4 and F (39) will assume significance of 10 = <u>PUMP DOWN VALVE</u> - in this case parameters C14 and u3 will assume significance of 11 = <u>ON/STAND-BY</u> - in this case "ON/STAND-BY" key will assume significance (42) 12 = <u>MAN IN COLD ROOM</u> - in this case parameters i5 and i15 will assume significance of

u1	0	12	-----	not avail.	not avail.	6	6	6	6	6	6	<p>application managed by the K5 (K3 in the models with direct load connection) digital output (35) (36)</p> <p>0 = reserved</p> <p>1 = <u>DEMISTER HEATING ELEMENTS</u> - in this case the "AUXILIARY" key and parameter u6 will be activated</p> <p>2 = <u>AUXILIARY OUTPUT</u> - in this case the "AUXILIARY" key and parameters i5, i15 and u2 will be activated</p> <p>3 = <u>ALARM OUTPUTS</u> - in this case parameter u4 will be activated</p> <p>4 = <u>DOOR HEATING ELEMENTS</u> - in this case parameter u5 will be activated</p> <p>5 = <u>HEATING ELEMENTS FOR NEUTRAL AREA OPERATION</u> - in this case parameter u7 will be activated</p> <p>6 = <u>CONDENSER FAN</u> - in this case parameters P4, F11 and F12 will be activated</p> <p>7 = <u>COMPRESSOR 2</u> - in this case, parameters r0, r12, C11, C12 and C13 (37) will assume significance of</p> <p>8 = <u>DEFROSTING 2</u> - in this case parameters P4 and d (38) will assume significance</p> <p>9 = <u>EVAPORATOR FAN 2</u> - in this case parameters P4 and F (39) will assume significance of</p> <p>10 = <u>PUMP DOWN VALVE</u> - in this case, parameters C14 and u3 will assume significance of (<u>RESERVED</u> in models EVB1246 and EVB1256)</p> <p>11 = <u>ON/STAND-BY</u> - in this case "ON/STAND-BY" key will assume significance (42)</p> <p>12 = <u>MAN IN COLD ROOM</u> - in this case, parameters i5 and i15 will assume significance of</p>
----	---	----	-------	------------	------------	---	---	---	---	---	---	---

u2	0	1	----	0	0	0	0	0	0	0	0	0	activation of room light switch on/off (in models EVB1204 and EVB1214 only if u1 = 0) or of the auxiliary output (in models EVB1204 and EVB1214 only if u1 = 2, in the remaining models only if u1 and/or u11 = 2) in manual mode with the device turned off (40). 1 = YES
u3	0	240	s	10	10	10	10	10	10	10	10	10	if C14 = 0 compressor switch-off delay after pump down valve switch-off if C14 = 1 or 2, maximum delay between pump down valve switch-off and compressor switch-off
u4	0	1	----	1	1	1	1	1	1	1	1	1	enabling of alarm output deactivation with the silencing of the buzzer (in models EVB1204 and EVB1214 only if u1 = 3, in the remaining models only if u1 and/or u11 = 3) 1 = YES
u5	-99.0	99.0	°C/°F (1)	-1.0	-1.0	-1.0	-1.0	-1.0	-1.0	-1.0	-1.0	-1.0	room temperature or CPT temperature below which the door heating elements are turned on ("u5 - 2.0°C/4°F in models EVB1204 and EVB1214 only if u1 = 4, in the remaining models only if u1 and u11 = 4).
u6	1	120	min	5	5	5	5	5	5	5	5	5	duration of demister heating elements activation (in models EVB1204 and EVB1214 only if u1 = 1, in the remaining models only if u1 and/or u11 = 1)
u7	-99.0	99.0	°C/°F (1)	-5.0	-5.0	-5.0	-5.0	-5.0	-5.0	-5.0	-5.0	-5.0	neutral area value (relative to the work set-point, i.e. "work set-point + u7) (in models EVB1204 and EVB1214 only if u1 = 5, in the remaining models only if u1 and/or u11 = 5) (41)

u9	0	1	-----	1	1	1	1	1	1	1	1	1	buzzer activation 1 = YES
u11	0	12	-----	not avail.	not avail.	3	3	3	3	3	3	3	application managed by the K6 digital output (35) (36) 0 = reserved 1 = <u>DEMISTER HEATING ELEMENTS</u> - in this case the "AUXILIARY" key and parameter u6 will be activated 2 = <u>AUXILIARY OUTPUT</u> - in this case the "AUXILIARY" key and parameters i5, i15 and u2 will be activated 3 = <u>ALARM OUTPUTS</u> - in this case parameter u4 will be activated 4 = <u>DOOR HEATING ELEMENTS</u> - in this case parameter u5 will be activated 5 = <u>HEATING ELEMENTS FOR NEUTRAL AREA OPERATION</u> - in this case parameter u7 will be activated 6 = <u>CONDENSER FAN</u> - in this case parameters P4, F11 and F12 will be activated 7 = <u>COMPRESSOR 2</u> - in this case, parameters r0, r12, C11, C12 e C13 (37) will assume significance 8 = <u>DEFROSTING 2</u> - in this case, parameters P4 and d (38) will assume significance 9 = <u>EVAPORATOR FAN 2</u> - in this case parameters P4 and F (39) will assume significance of 10 = <u>PUMP DOWN VALVE</u> - in this case, parameters C14 and u3 will assume significance of (<u>RESERVED</u> in models EVB1246 and EVB1256) 11 = <u>ON/STAND-BY</u> - in this case "ON/STAND-BY" key will assume significance (42) 12 = <u>MAN IN COLD ROOM</u> - in this case, parameters i5 and i15 will assume significance of

PARAM.	MIN.	MAX.	M.U.	EVB1204	EVB1214	EVB1206	EVB1216	EVB1226	EVB1236	EVB1246	EVB1256	CLOCK
Hr0	0	1	-----	not avail.	1	not avail.	1	not avail.	1	not avail.	1	clock activation, together with the functions that require it 1 = YES
PARAM.	MIN.	MAX.	M.U.	EVB1204	EVB1214	EVB1206	EVB1216	EVB1226	EVB1236	EVB1246	EVB1256	ENERGY SAVING
HE2	0	999	min	0	0	0	0	0	0	0	0	maximum duration of the "energy saving" function activated due to the effect of absence of door micro switch input activation; see also i10 0 = the function will last until the input is activated
H01	0	23	h	not avail.	0	not avail.	0	not avail.	0	not avail.	0	activation time of the "energy saving" function every Monday; see also r4, F13, F14 and H02
H02	0	24	h	not avail.	0	not avail.	0	not avail.	0	not avail.	0	duration of the "energy saving" function every Monday; see also H01
H03	0	23	h	not avail.	0	not avail.	0	not avail.	0	not avail.	0	activation time of the "energy saving" function every Tuesday; see also r4, F13, F14 and H04
H04	0	24	h	not avail.	0	not avail.	0	not avail.	0	not avail.	0	duration of the "energy saving" function every Tuesday; see also H03
H05	0	23	h	not avail.	0	not avail.	0	not avail.	0	not avail.	0	activation time of the "energy saving" function every Wednesday; see also r4, F13, F14 and H06

H06	0	24	h	not avail.	0	not avail.	0	not avail.	0	not avail.	0	duration of the "energy saving" function every Wednesday; see also H05
H07	0	23	h	not avail.	0	not avail.	0	not avail.	0	not avail.	0	activation time of the "energy saving" function every Thursday; see also r4, F13, F14 and H08
H08	0	24	h	not avail.	0	not avail.	0	not avail.	0	not avail.	0	duration of the "energy saving" function every Thursday; see also H07
H09	0	23	h	not avail.	0	not avail.	0	not avail.	0	not avail.	0	activation time of the "energy saving" function every Friday; see also r4, F13, F14 and H10
H10	0	24	h	not avail.	0	not avail.	0	not avail.	0	not avail.	0	duration of the "energy saving" function every Friday; see also H09
H11	0	23	h	not avail.	0	not avail.	0	not avail.	0	not avail.	0	activation time of the "energy saving" function every Saturday; see also r4, F13, F14 and H12
H12	0	24	h	not avail.	0	not avail.	0	not avail.	0	not avail.	0	duration of the "energy saving" function every Saturday; see also H11
H13	0	23	h	not avail.	0	not avail.	0	not avail.	0	not avail.	0	activation time of the "energy saving" function every Sunday; see also r4, F13, F14 and H14
H14	0	24	h	not avail.	0	not avail.	0	not avail.	0	not avail.	0	duration of the "energy saving" function every Sunday; see also H13

PARAM.	MIN.	MAX.	M.U.	EVB1204	EVB1214	EVB1206	EVB1216	EVB1226	EVB1236	EVB1246	EVB1256	DEFROSTING IN REAL TIME
Hd1	h0	h--	h	not avail.	h--	not avail.	h--	not avail.	h--	not avail.	h--	time of activation of first daily defrosting (only if d8 = 4) h-- = the first defrosting will not be activated
Hd2	h0	h--	h	not avail.	h--	not avail.	h--	not avail.	h--	not avail.	h--	time of activation of second daily defrosting (only if d8 = 4) h-- = the second defrosting will not be activated
Hd3	h0	h--	h	not avail.	h--	not avail.	h--	not avail.	h--	not avail.	h--	time of activation of third daily defrosting (only if d8 = 4) h-- = the third defrosting will not be activated
Hd4	h0	h--	h	not avail.	h--	not avail.	h--	not avail.	h--	not avail.	h--	time of activation of fourth daily defrosting (only if d8 = 4) h-- = the fourth defrosting will not be activated
Hd5	h0	h--	h	not avail.	h--	not avail.	h--	not avail.	h--	not avail.	h--	time of activation of fifth daily defrosting (only if d8 = 4) h-- = the fifth defrosting will not be activated
Hd6	h0	h--	h	not avail.	h--	not avail.	h--	not avail.	h--	not avail.	h--	time of activation of sixth daily defrosting (only if d8 = 4) h-- = the sixth defrosting will not be activated

PARAM.	MIN.	MAX.	U.M.	EV1204	EV1214	EV1206	EV1216	EV1226	EV1236	EV1246	EV1256	DATA LOGGING EXTENSION
Sd0	1	30	min	not avail.	30	not avail.	30	not avail.	not avail.	not avail.	30	writing interval in "HACCP" mode
Sd1	1	30	min	not avail.	1	not avail.	1	not avail.	not avail.	not avail.	1	writing interval in "service" mode
Sd2	1	240	min	not avail.	60	not avail.	60	not avail.	not avail.	not avail.	60	duration of the "service" writing mode
Sd3	0	1	----	not avail.	0	not avail.	0	not avail.	not avail.	not avail.	0	enabling the auxiliary 3 temperature probe 1 = YES
Sd4	0	1	----	not avail.	0	not avail.	0	not avail.	not avail.	not avail.	0	enabling the writing of the room temperature value 1 = YES
Sd5	0	1	----	not avail.	1	not avail.	1	not avail.	not avail.	not avail.	1	kind of decimal separator 0 = comma 1 = point
Sd6	0	2	----	not avail.	1	not avail.	1	not avail.	not avail.	not avail.	1	kind of auxiliary 2 temperature probe and auxiliary 3 temperature probe; also look at P0 0 = reserved 1 = NTC 2 = Pt 1000

PARAM.	MIN.	MAX.	M.U.	EVB1204	EVB1214	EVB1206	EVB1216	EVB1226	EVB1236	EVB1246	EVB1256	RS-485 MODBUS
LA	1	247	----	247	247	247	247	247	247	247	247	device address
Lb	0	3	----	2	2	2	2	2	2	2	2	baud rate 0 = 2.400 baud 1 = 4.800 baud 2 = 9.600 baud 3 = 19.200 baud
LP	0	2	---	2	2	2	2	2	2	2	2	parity 0 = none (no parity) 1 = odd 2 = even

Notes:

- (1) the unit of measurement depends on P2
- (2) Properly set the parameters corresponding to the regulators after setting parameter P2
- (3) The formula for the calculation of the CPT temperature is:

$$\text{CPT temperature} = \{[(P7) \times (\text{temperature detected by the inlet air probe})] + [(100 - P7) \times (\text{temperature detected by the outlet air probe})] : 100\}$$
- (4) the unit of measurement depends on P9 and P10
- (5) the value depends on parameter P2 (0,1 °C or 1 °F)
- (6) if parameter r12 is set to 0, the compressor will be switched on when the room temperature or CPT temperature is above the "working set-point + r0" and will be switched off when the temperature falls below the working set-point; if parameter r12 is set to 1, the compressor will be switched on when the room temperature or CPT temperature is above the "working set-point + r0/2" and will be switched off when the temperature falls below the "working set-point - r0/2"

- (7) if parameter r12 is set to 0:
- a compressor will be switched on when the room temperature or CPT temperature is above the "working set-point + r0/2" and another when the temperature is above the "working set-point + r0"
 - a compressor will be switched off when the room temperature or CPT temperature falls below the "working set-point + r0/2" and another when the temperature is below the working set-point
- if parameter r12 is set to 1:
- a compressor will be switched on when the room temperature or CPT temperature is above the working set-point and another when the temperature is above the "working set-point + r0/2"
 - a compressor will be switched off when the room temperature or CPT temperature falls below the "working set-point + r0/2" and another when the temperature is below the "working set-point - r0/2"
- the choice of which compressor to switch on/off depends on parameters C12 and C13
- (8) the parameter has effect even after an interruption in the power supply that occurs while the device is switched on
- (9) the time established with the parameter is counted even when the device is switched off
- (10) if parameter C1 is set at 0, the delay after the end of the room temperature/inlet air probe error will be 2 min
- (11) the parameter differential is 2,0 °C/4 °F
- (12) if when the device is switched on, the condenser temperature is already above that established in parameter C7, then parameter C8 will not have effect
- (13) the device memorises the defrosting interval count every 30 minutes; the setting of parameters d0 and d26 has effect from the conclusion of the previous defrosting interval or the activation of defrosting in manual mode
- (14) the display restores normal operation when, on conclusion of evaporator fan standstill, the room temperature or CPT temperature drops below that which has blocked the display (or if a temperature alarm occurs)
- (15) the value of Δt depends on parameter r12 (r0 if r12 = 0, r0/2 if r12 = 1)
- (16) the display restores normal operation on conclusion of evaporator fan standstill (or if a temperature alarm occurs)
- (17) if parameter P3 is set at 0 or 2, the device will function as if parameter d8 were set at 0
- (18) if when defrosting is activated, the operating duration of the compressor is less than the time established with parameter d5, the compressor will remain on for the amount of time necessary to complete defrosting
- (19) if parameter d8 is set at 2 or 3, the device will operate as if the parameter as been set at 0 and defrosting will be activated when the device has been on totally for the time established with parameter d26
- (20) if parameter P3 is set at 0, the device will function as if parameter A0 were set at 0 but it will not store the alarm
- (21) during defrosting and dripping and when the evaporator fan is stopped, the temperature alarms are absent, provided that these were signalled after the activation of defrosting
- (22) during activation of the door microswitch input, the maximum temperature alarm is absent, provided the alarm was signalled after the activation of the input
- (23) parameters F13 and F14 have effect when the compressor is off
- (24) parameters F13 and F14 have effect when the compressor is on
- (25) if parameter P3 is set at 0, the device will function as if parameter F0 were set at 2
- (26) parameters F13 and F14 have effect when the evaporator temperature is below the temperature established with parameter F1
- (27) parameters F13 and F14 have effect when the compressor is on and the temperature of the evaporator is below the temperature established with parameter F1
- (28) the parameter can be changed also by implementing the procedure described in paragraph "Setting the configuration parameters"
- (29) if parameter P4 is set at 0, 2, 3 or 4, the condenser fan will function in parallel with the compressor

- (30) the condenser fan is on on condition that the compressor is on and is off when the temperature of the condenser drops below the temperature established with parameter F11 on condition that the compressor is off
- (31) the compressor is switched off 10 sec after the activation of the input; if the input is activated during defrosting or when the evaporator fan is deactivated, the activation will not have any effect on the compressor
- (32) the device stores the alarm once the time established in parameter i2 has expired; if parameter i2 is set at -1, the device will not store the alarm
- (33) if the parameter i5 i0 and parameter i15 are set at the same value, the effect will be caused by the activation of at least one of the inputs (until both inputs are deactivated)
- (34) make sure that the time established with parameter i7 is less than that established with parameter i9
- (35) to avoid damaging the unit connected to the instrument, set the parameter setting when the device is switched off
- (36) make sure that parameter u1 is not set at 1 when parameter u11 is set at 2 (and vice versa)
- (37) if parameter d8 is set at 3, the setting shall have no effect and the device shall operate as if the parameter were set at 0
- (38) if parameter d8 is set at 2 or 3, the setting shall have no effect and the device shall operate as if the parameter were set at 0; it is suggested to set parameter P4 at 3 (the evaporator temperature probe shall be associated with defrosting and the evaporator 2 temperature probe shall be associated with defrosting 2)
- (39) it is suggested to set parameter P4 at 3 (the evaporator temperature probe shall be associated with the evaporator fan and the evaporator 2 temperature probe shall be associated with the evaporator 2 fan)
- (40) if parameter u2 is set at 0, switching off the device may cause the room light and/or the auxiliary output to switch off (the next time the instrument is switched on the unit connected will remain switched off); if parameter u2 is set at 1, switching off the device will not cause the room light or the auxiliary output to switch off (the next time the instrument is switched on the unit connected will remain switched on)
- (41) the heating elements are switched on when the room temperature of the cabinet or the CPY temperature drops below the "work set-point + u7" and are switched off when the temperature rises above the "work set-point + u7 + 2 °C/°F"
- (42) the switching on of the device shall switch on the application and the switching off of the device shall switch off the application
- (43) the parameter is in ten (for example, 1 = 10 steps, 10 = 100 steps, etc.)
- (44) the parameter differential is 2,0 bar g / PSI g
- (45) the models integrating the unipolar electronic expansion valves driver do not support the backup module for the valve closure in case of lack of power supply; it is suggested to set parameter u1 (or u11) to 11 and connect the digital output K5 (or K6) to a solenoid valve.

14 WARNING LIGHTS AND DIRECTIONS

14.1 Signals

The following table shows the meaning of the LED warning lights of the device.

LED	MEANING
⊛	<p>Compressor LED light</p> <p>If the LED is on:</p> <ul style="list-style-type: none"> - the compressor is on <p>If the LED is flashing:</p> <ul style="list-style-type: none"> - the working set point is in the process of being set (via the procedure described in paragraph "Setting the working set point") - a compressor protection will be in progress; see parameters C0, C1, C2, C11 and i7
⊛	<p>Defrost LED</p> <p>If the LED is on:</p> <ul style="list-style-type: none"> - defrosting is in progress - predripping will be in progress; see parameter d16 <p>If the LED is flashing:</p> <ul style="list-style-type: none"> - defrosting will be requested but a compressor protection will be in progress; see the parameters C0, C1 and C2 - dripping will be in progress; see parameter d7 - the refrigerant fluid heating will be in progress; see parameter d15
⊛	<p>Evaporator fan LED light</p> <p>If the LED is on:</p> <ul style="list-style-type: none"> - the evaporator fan will be on <p>If the LED is flashing:</p> <ul style="list-style-type: none"> - evaporator fan standstill will be in progress; see parameter F3
⊛	<p>room light LED</p> <p>If the LED is on:</p> <ul style="list-style-type: none"> - the room light has been turned on manually (only if the parameter u1 and/or parameter u11 is set at 0) <p>If the LED is flashing:</p> <ul style="list-style-type: none"> - the room light has been turned from a digital input ; see parameter i0 (only if the parameter u1 and/or parameter u11 is set at 0)

<p>AUX1 and AUX2</p>	<p>Auxiliary LED 1 and Auxiliary LED 2</p> <p>If the LED is on:</p> <ul style="list-style-type: none"> - the demister heating elements will be switched on (only if the parameter u1 and/or parameter u11 is set at 1) - the auxiliary output will have been switched on in manual mode (only if the parameter u1 and/or parameter u11 is set at 2) - the door heating elements will be switched on (only if the parameter u1 and/or parameter u11 is set at 4) - the neutral area operating heating elements will be activated (only if the parameter u1 and/or parameter u11 is set at 5) - the condenser fan will be on (only if the parameter u1 and/or parameter u11 is set at 6) - compressor 2 will be on (only if the parameter u1 and/or parameter u11 is set at 7) - the defrosting output 2 will be on (only if the parameter u1 and/or parameter u11 is set at 8) - evaporator 2 fan will be on (only if the parameter u1 and/or parameter u11 is set at 9) - the pump down valve will be on (only if the parameter u1 and/or parameter u11 is set at 10) - the on/stand-by output will be on (only if the parameter u1 and/or parameter u11 is set at 11) - the man in cold room output will be on (only if the parameter u1 and/or parameter u11 is set at 12) <p>If the LED is flashing:</p> <ul style="list-style-type: none"> - compressor 2 protection will be in progress; see parameters C0, C1, C2, C11 and i7 - evaporator fan 2 standstill will be in progress; see parameter F3 - the auxiliary out put will have been switched on from a digital input; see parameters i5 and i15 (only if the parameter u1 and/or parameter u11 is set at 2)
<p>⌚</p>	<p>Clock LED light</p> <p>If the LED is on:</p> <ul style="list-style-type: none"> - the value displayed shall be a time <p>If the LED is flashing:</p> <ul style="list-style-type: none"> - the date, time and day of the week are being set
<p>⊖</p>	<p>temperature LED light</p> <p>If the LED is on:</p> <ul style="list-style-type: none"> - the value displayed shall be a temperature <p>If the LED is flashing:</p> <ul style="list-style-type: none"> - the "rapid cooling" function is in progress; see parameters r5 and r6
<p>Ⓜ</p>	<p>pressure LED light</p> <p>If the LED is on:</p> <ul style="list-style-type: none"> - the value displayed shall be a pressure
<p>HACCP</p>	<p>HACCP LED light</p> <p>If the LED is on:</p> <ul style="list-style-type: none"> - not all the information on the HACCP alarms has been displayed <p>If the LED is flashing:</p> <ul style="list-style-type: none"> - if it is flashing, the device has saved at least one new HACCP alarm
<p>⊕</p>	<p>Energy saving LED light</p> <p>If the LED is on:</p> <ul style="list-style-type: none"> - the "energy saving" function is in progress

- | | |
|---|--|
| △ | <p>Alarm LED light</p> <p>If the LED is on:</p> <ul style="list-style-type: none"> - an alarm is in progress <p>If the LED is flashing:</p> <ul style="list-style-type: none"> - compressor maintenance is required; see parameter C10 |
|---|--|

SD card status LED

If it is green firmly:

- no writing will be in progress and the data logger battery will fully be charged; the SD card is in the slot and can be removed.

If it is red firmly:

- the writing will be in progress; the SD card is in the slot and can not be removed.

If it is green flashing:

- no writing will be in progress and the data logger battery will be charging; the SD card is in the slot and can be removed.

If it is red flashing:

- the SD card will not be in the slot.

14.2 Signal Descriptions/Explanations

The following table shows the meaning of the signal codes of the device.

CODE	MEANING
Loc	<ul style="list-style-type: none"> - the keyboard is blocked; see paragraph 6.11 "Keyboard locking/unlocking" - the work set point is blocked; see parameter r3
- - - -	The operation requested is not available

15 ALARMS

15.1 Alarms

The following table shows the meaning of the alarm codes of the device.

CODE	MEANING
AL	<p>Minimum alarm temperatures (HACCP alarms)</p> <p>Solutions:</p> <ul style="list-style-type: none"> - check the temperature associated to the alarm; see parameters A0, A1 and A2 <p>Main consequences:</p> <ul style="list-style-type: none"> - if parameter A0 is set at 0, the device will store the alarm - the alarm output will be activated (provided that parameter u1 and/or parameter u11 is set at 3)
AH	<p>Maximum temperature alarm (HACCP alarms)</p> <p>Solutions:</p> <ul style="list-style-type: none"> - check the room temperature or CPT temperature; see parameters A4 and A5 <p>Main consequences:</p> <ul style="list-style-type: none"> - the device will memorise the alarm - the alarm output will be activated (provided that parameter u1 and/or parameter u11 is set at 3)
id	<p>Door micro switch input alarm (HACCP alarms)</p> <p>Solutions:</p> <ul style="list-style-type: none"> - check the causes of the activation of the input; see parameters i0 and i1 <p>Main consequences:</p> <ul style="list-style-type: none"> - the effect established with the parameter i0 - if parameter i4 is set at 1, the device will store the alarm, provided parameter i2 is not set at -1 - the alarm output will be activated (provided that parameter u1 and/or parameter u11 is set at 3)
PF	<p>Power supply cut-off alarm (HACCP alarm)</p> <p>Solutions:</p> <ul style="list-style-type: none"> - check the causes triggering the power supply cut-off; see parameters A10 and A12 - press a key to restore normal display <p>Main consequences: Main consequences:</p> <ul style="list-style-type: none"> - if the interruption lasts longer than the time established with parameter A10, the device will store the alarm - the alarm output will be activated (provided that parameter u1 and/or parameter u11 is set at 3)
iA	<p>Multifunction and Multifunction 2 input alarm</p> <p>Solutions:</p> <ul style="list-style-type: none"> - check the causes of the activation of the input; see parameters i5, i6, i15 and i16 <p>Main consequences:</p> <ul style="list-style-type: none"> - the effect established with the parameters i5 and i15 - the alarm output will be activated (provided that parameter u1 and/or parameter u11 is set at 3)

iSd	<p>Maximum pressure switch alarm</p> <p>Solutions:</p> <ul style="list-style-type: none"> - check the causes of the activation of the input; see parameters i5, i6, i7, i8, i9, i15 and i16 - switch off and re-start the device or suspend the power supply <p>Main consequences:</p> <ul style="list-style-type: none"> - the regulators will switch off - the alarm output will be activated (provided that parameter u1 and/or parameter u11 is set at 3)
LP	<p>Minimum pressure switch alarm</p> <p>Solutions:</p> <ul style="list-style-type: none"> - check the evaporating pressure; see parameters h12 and h13 - check the causes of the activation of the input; see parameters i5, i6, i15, i16 and i17 <p>Main consequences:</p> <ul style="list-style-type: none"> - the compressor will be switched off - the alarm output will be activated (provided that parameter u1 and/or parameter u11 is set at 3) - the electronic expansion valve will be closed
HSH	<p>High superheating alarm alarm</p> <p>Solutions:</p> <ul style="list-style-type: none"> - check the evaporating temperature; see parameters h02 <p>Main consequences:</p> <ul style="list-style-type: none"> - the alarm output will be activated (provided that parameter u1 and/or parameter u11 is set at 3)
C1t	<p>Compressor thermal protection alarm</p> <p>Solutions:</p> <ul style="list-style-type: none"> - check the causes of the activation of the input; see parameters i5, i6, i15 and i16 <p>Main consequences:</p> <ul style="list-style-type: none"> - the compressor will be switched off - if parameter u1 and/or parameter u11 is set at 7 (or in case of operation with two compressors), the device shall operate exactly as it would with only one compressor (compressor 2) - the alarm output will be activated (provided that parameter u1 and/or parameter u11 is set at 3)
C2t	<p>Compressor 2 thermal protection alarm</p> <p>Solutions:</p> <ul style="list-style-type: none"> - check the causes of the activation of the input; see parameters i5, i6, i15 and i16 <p>Main consequences:</p> <ul style="list-style-type: none"> - compressor 2 will be switched off (only if the parameter u1 and/or parameter u11 is set at 7) - the device shall operate exactly as it would with only one compressor (compressor 1) - the alarm output will be activated (provided that parameter u1 and/or parameter u11 is set at 3)
MiC	<p>Man in Cold room alarm</p> <p>Solutions:</p> <ul style="list-style-type: none"> - check the causes of the activation of the input; see parameters i5, i6, i15 and i16 <p>Main consequences:</p> <ul style="list-style-type: none"> - the man in cold room output will be switched on (only if the parameter u1 and/or parameter u11 is set at 12) - the alarm output will be activated (provided that parameter u1 and/or parameter u11 is set at 3)

COH	<p>Condenser overheated alarm</p> <p>Solutions:</p> <ul style="list-style-type: none"> - check the condenser temperature; see parameter C6 <p>Main consequences:</p> <ul style="list-style-type: none"> - the alarm output will be activated (provided that parameter u1 and/or parameter u11 is set at 3) - the condenser fan will be on (only if parameter u1 and/or parameter u11 is set at 6)
CSd	<p>Compressor shut down alarm.</p> <p>Solutions:</p> <ul style="list-style-type: none"> - check the condenser temperature; see parameter C7 - switch the device off and back on again: if when the device is switched back on, the temperature of the condenser is still higher than that established in parameter C7, disconnect the power supply and clean the condenser <p>Main consequences:</p> <ul style="list-style-type: none"> - the compressor and the evaporator fan will be switched off - the alarm output will be activated (provided that parameter u1 and/or parameter u11 is set at 3) - the condenser fan will be on (only if parameter u1 and/or parameter u11 is set at 6)
dFd	<p>Defrosting alarm switched off because maximum time has been reached</p> <p>Solutions:</p> <ul style="list-style-type: none"> - check the integrity of the evaporator temperature probe; see parameters d2, d3 and d11 - press a key to restore normal display <p>Main consequences:</p> <ul style="list-style-type: none"> - the device will continue to operate normally
Pd	<p>Pump down alarm (from digital input) finished for maximum duration</p> <p>Solutions:</p> <ul style="list-style-type: none"> - check the integrity of the sensor switching off the compressor <p>Main consequences:</p> <ul style="list-style-type: none"> - the device will continue to operate normally

When the cause of the alarm disappears, the device restores normal operation, except for the following alarms:

- the power supply interruption alarm (code "**PF**") which requires the pressing of a key
- maximum pressure switch alarm (code "**iSd**") which requires the switching off of the device or the temporary suspension of the power supply
- compressor blocked by condenser temperature alarm (code "**CSd**") which requires the switching off of the device or the temporary suspension of the power supply
- defrosting alarm switched off because maximum time has been reached (code "**dFd**") which requires the pressing of a key.

16 ERRORS

16.1 Errors

The following table shows the meaning of the error codes of the device.

CODE	MEANING
Pr1	<p>room temperature/inlet air temperature probes error</p> <p>Solutions:</p> <ul style="list-style-type: none"> - check that the probe is the PTC, NTC or Pt 1000 type; see parameter P0 - check the device-probe connection - check room/inlet air temperature <p>Main consequences:</p> <ul style="list-style-type: none"> - compressor activity will depend on parameters C4 and C5 - the defroster will not be activated - the alarm output will be activated (provided that parameter u1 and/or parameter u11 is set at 3) - the door heating elements will be switched off (only and provided parameter u1 and/or parameter u11 is set at 4) - the neutral area operating heating elements will be deactivated (only if parameter u1 and/or parameter u11 is set at 5) - if parameter P4 is set at 3, the temperature associated to regulation will be that detected by the outlet air temperature probe
Pr2	<p>Evaporator temperature probe error</p> <p>Solutions:</p> <ul style="list-style-type: none"> - the same as the preceding case but with respect to the evaporator temperature probe <p>Main consequences:</p> <ul style="list-style-type: none"> - if parameter P3 is set at 1, the defrosting period will last for the amount of time set with parameter 3 - if parameter P3 is set at 1 and parameter d8 is set at 2 or to 3, the device will operate as if parameter d8 were set at 0 - if parameter F0 is set at 3 or 4, the device will operate as if the parameter were set at 2 - the alarm output will be activated (provided that parameter u1 and/or parameter u11 is set at 3)
Pr3	<p>Auxiliary temperature probe error</p> <p>Solutions:</p> <ul style="list-style-type: none"> - the same as in the previous example, but with regard to the auxiliary temperature probe <p>Main consequences:</p> <ul style="list-style-type: none"> - if parameter P4 is set at 1: <ul style="list-style-type: none"> - condenser overheated alarm (code "COH") will never be activated - the compressor blocked alarm (code "Csd") will never be activated - the condenser fan will operate parallel to the compressor (only if parameter u1 and/or parameter u11 is set at 6) - the alarm output will be activated (provided that parameter u1 and/or parameter u11 is set at 3) - if parameter P4 is set at 3, the temperature associated to regulation will be that detected by the inlet air temperature probe
Pr4	<p>Evaporation temperature probe error</p> <p>Solutions:</p> <ul style="list-style-type: none"> - the same as in the previous example, but with regard to the evaporation temperature probe <p>Main consequences:</p> <ul style="list-style-type: none"> - the electronic expansion valve will be open the percentage set with parameter h17 - the alarm output will be activated (provided that parameter u1 and/or parameter u11 is set at 3)

Pr5	<p>Evaporation pressure probe error</p> <p>Solutions:</p> <ul style="list-style-type: none"> - check that the probe is the 4-20 mA type - check the device-probe connection - check the vapour pressure <p>Main consequences:</p> <ul style="list-style-type: none"> - the electronic expansion valve will be open the percentage set with parameter h17 - the alarm output will be activated (provided that parameter u1 and/or parameter u11 is set at 3)
Pr7	<p>Auxiliary 2 temperature probe error</p> <p>Solutions:</p> <ul style="list-style-type: none"> - check that the probe is the NTC or Pt 1000 type; see parameter Sd6 - check the device-probe connection - check auxiliary 2 temperature <p>Main consequences:</p> <ul style="list-style-type: none"> - the device will record the error - the alarm output will be activated (provided that parameter u1 and/or parameter u11 is set at 3)
Pr8	<p>Auxiliary 3 temperature probe error</p> <p>Solutions:</p> <ul style="list-style-type: none"> - the same as in the previous example, but with regard to the auxiliary 3 temperature probe <p>Main consequences:</p> <ul style="list-style-type: none"> - the device will record the error - the alarm output will be activated (provided that parameter u1 and/or parameter u11 is set at 3)
FUL	<p>Error SD card space run out</p> <p>Solutions:</p> <ul style="list-style-type: none"> - get free space on the SD card or replace it <p>Main consequences:</p> <ul style="list-style-type: none"> - the device will not write information
Sd	<p>Error SD card not inserted or not recognized</p> <p>Solutions:</p> <ul style="list-style-type: none"> - insert the SD card or replace it <p>Main consequences:</p> <ul style="list-style-type: none"> - the device will not write information
BAt	<p>Data logger battery error</p> <p>Solutions:</p> <ul style="list-style-type: none"> - check the battery is charged <p>Main consequences:</p> <ul style="list-style-type: none"> - the device will not write information

	Clock error
	Solutions:
	- set the date, time and day of the week
	Main consequences:
rtc	- if parameter d8 is set at 4, the device will operate as if it were set at 0
	- the "HACCP" function will not provide information regarding the date and hour in which the alarm was signalled
	- the "energy saving" function n real time function will not be activated in real time
	- the alarm output will be activated (provided that parameter u1 and/or parameter u11 is set at 3)

When the cause of the error disappears, the device restores normal operation, except for clock error ("**rtc**" code), which requires the date, time and day of the week set.

17 ACCESSORIES

17.1 Non opto-isolated RS-485/USB serial interface EVIF20SUXI

17.1.1 Preliminary notes

The interface makes it possible to connect the device to the Parameters Manager set-up software system.



17.2 Data recorder EVUSBREC01

17.2.1 Preliminary notes

The device records the board data and their download (via USB in a CSV file format).



17.3 USB cover for panel installation 081200002

17.3.1 Preliminary notes

Through the cover it is possible to make the USB-type communication port more accessible for EVUSBREC01 data recording.

To connect the cover to the device it is necessary to use also the 0810500018 or 0810500020 connection cable (to be ordered separately).



17.4 0810500018/0810500020 connection cable

17.4.1 Preliminary notes

The cables can be used to connect the USB cover for panel installation 0812000002 to the EVUSBREC01 data recorder.

The 0810500018 cable is 2.0 m long; the 0810500020 cable is 0.5 m long.



18 TECHNICAL DATA

18.1 Technical data

Purpose of the command device:	operating command device.
Construction of the command device:	built-in electronic device.
Container:	grey self-extinguishing.
Heat and fire protection class:	D.
Dimensions:	262.0 x 179.0 x 95.6 mm (10.314 x 7.047 x 3.763 in; L x H x D).
Method of mounting the command device:	wall mounted, with bolts and fastening screws.
Shell protection grade:	IP65.
Connection method:	<ul style="list-style-type: none"> - screw in terminal boards 6.35 mm pitch (0.25 in) for wires up to 4 mm² (0.0062 in²): power supply and digital outputs - screw in terminal boards 5.0 mm pitch (0.196 in) for wires up to 2.5 mm² (0.0038 in²): analogue inputs, digital inputs and RS-485 MODBUS port - screw in removable terminal board, male only 3.5 mm pitch (0.137 in) for wires up to 1.5 mm² (0.0028 in²) or JST male only 6-way connector 2.5 mm pitch (0.098 in): driver for unipolar stepper electronic expansion valves. <p>The maximum lengths of the connection cables are:</p> <ul style="list-style-type: none"> - power supply: 100 m (328 ft) - analogue inputs: 100 m (328 ft) - transducers power supply: 100 m (328 ft) - digital inputs: 100 m (328 ft) - digital outputs: 100 m (328 ft) - RS-485 MODBUS port: 1,000 m (3,280 ft); please refer also to the <i>MODBUS specifications and implementation guides</i> available at http://www.modbus.org/specs.php - driver for unipolar stepper electronic expansion valves: 3 m (9.842 ft) <p>Use cables having a section suitable to the current running through them.</p> <p>In case of use of the device to the maximum operating temperature and to full load, use cables having maximum operating temperature ≥ 90 °C (194 °F).</p>

Operating temperature:	from 0 to 45 °C (from 32 to 113 °F) the models with differential magneto-thermal circuit breaker and with remote control switch for three-phase defrost elements management, from 0 to 50 °C (from 32 to 122 °F) otherwise.
Storage temperature:	from -25 to 70 °C (from -13 to 158 °F).
Humidity for use:	from 10 to 90 % relative humidity without condensate.
Command device pollution situation:	2.
Height at which it is used:	from 0 to 2,000 m (from 0 to 6,591 ft).
Height at which it can be transported:	from 0 to 3,048 m (from 0 to 10,000 ft).
Environmental standards:	<ul style="list-style-type: none"> - RoHS 2011/65/CE - WEEE 2012/19/EU - REACH (CE) regulation n. 1907/2006.
EMC standards:	<ul style="list-style-type: none"> - EN 60730-1 - IEC 60730-1.
Power supply:	115... 230 VAC (+10 %, -15 %), 50/60 Hz (± 3 Hz), 35 VA max., supplied by a class 2 circuit. The maximum phase current allowed is 16 A.
Magneto-thermal switch:	according to model (230 VAC, In 16 A, Icn 4.500 A, unipolar + neutral, for wires up to 2,5 mm ² (0.0387 in ²).
Differential magneto-thermal circuit breaker:	according to model (230 VAC, In 16 A, Icn 4.500 A, Id 300 mA, unipolar + neutral, for wires up to 2,5 mm ² (0.0387 in ²).
Remote control switch for three-phase defrost elements management:	according to model (230 VAC, Ie 9 A, Ui 690 V, Uimp 6 KV, Ith 20 A, 2,2 KW in AC3 at 230 VAC with ta 55 °C, three poles + neutral, for wires up to 2,5 mm ² (0,0387 in ²).
Control device grounding method:	with ground terminal
Rated impulse voltage:	4 KV.
Overvoltage category:	III.
Class and structure of software:	A.

Real time clock:	incorporated (with lithium secondary battery).
	Battery autonomy without power supply: 6 months.
	Battery recharging time: 24 h (the battery is recharged through the device power supply).
	Drift: ≤ 30 s/month at 25 °C (77 °F).
Data logger battery:	according to the model (nickel-metal hydride secondary battery)
	Battery range in absence of power supply: more than 72 h.
	Battery charging time: 24 h (the battery is charged by the power supply of the device).
Analogue inputs	<p>according to model, up to 7 inputs:</p> <ul style="list-style-type: none"> - 3 configurable via configuration parameter for PTC, NTC or Pt 1000 probes (room temperature, evaporator temperature and evaporation temperature) - 1 configurable via configuration parameter for PTC, NTC or Pt 1000 probes (configurable via configuration parameter for condenser temperature, critical temperature, evaporator 2 temperature or CPT temperature) - 2 configurable via configuration parameter for NTC or Pt 1000 probes (auxiliary 2 temperature and auxiliary 3 temperature) - 1 for 4-20 mA transducers (vapour pressure).
	4-20 mA transducers power supply: 12 VDC (± 10 %), 30 mA max.
	<p><u>Analogue inputs PTC (990 @ 25 °C, 77 °F)</u></p> <p>Type of sensor: KTY 81-121.</p> <p>Measurement field: from -50 to 150 °C (from -58 to 302 °F).</p> <p>Precision: $\pm 0,5$ % of scale end.</p> <p>Resolution : 0,1 °C (1 °F).</p> <p>Protection: none.</p>
	<p><u>Analogue inputs NTC (10 K @ 25 °C, 77 °F)</u></p> <p>Type of sensor: B3435.</p> <p>Measurement field: from -50 to 120 °C (from -58 to 248 °F).</p> <p>Precision: $\pm 0,5$ % of scale end.</p> <p>Resolution : 0,1 °C (1 °F).</p> <p>Protection: none.</p>

	<p><u>Analogue inputs Pt 1000 (1 K @ 0 °C, 32 °F)</u></p> <p>Measurement field: from -99 to 150 °C (from -99 to 302 °F).</p> <p>Precision: ±0,5 % of scale end.</p> <p>Resolution : 0,1 °C (1 °F).</p> <p>Protection: none.</p>
	<p><u>Analogue inputs 4-20 mA</u></p> <p>Input resistance: ≤ 200 .</p> <p>Precision: ±0,5 % of scale end.</p> <p>Resolution : 0.01 mA.</p> <p>Protection: none; maximum allowable current at each input is 25 mA.</p>
Digital inputs:	<p>3 inputs, configurable via configuration parameter for NA or NC contact (micro port, multifunction 1 and multifunction 2)</p>
	<p><u>Digital inputs at 5 VDC mA (clean contact)</u></p> <p>Power: none.</p> <p>Protection: none.</p>
Displays:	<p>custom 3 digit display with decimal point and function icon.</p>

<p>Digital outputs:</p>	<p>according to model, up to 6 outputs:</p> <ul style="list-style-type: none"> - 2 SPST electromechanical relays with 30 A res. @ 250 VAC (compressor and evaporator fan) - 2 SPST electromechanical relays with 16 A res. @ 250 VAC (defrosting and room light) - 1 SPST electromechanical relay with 8 A res. @ 250 VAC (configurable through a configuration parameter for demister heating elements, auxiliary, alarms, door resistors, neutral area operation resistors, condenser fan, compressor 2, defrosting 2, evaporator fan 2, pump down valve, on/stand-by or man in cold room; for manufacturer default for the condenser fan). - 1 SPDT electromechanical relay with 8 A res. @ 250 VAC (configurable through a configuration parameter for demister heating elements, auxiliary, alarms, door resistors, neutral area operation resistors, condenser fan, compressor 2, defrosting 2, evaporator fan 2, pump down valve, on/stand-by or man in cold room; for manufacturer default for the condenser fan). <p>The device guarantees reinforced insulation between each connector of the digital outputs and the other parts of the device.</p>
<p>Driver for unipolar stepper electronic expansion valves.</p>	<p>12 VDC, 260 mA max.</p>
<p>Type 1 or Type 2 actions:</p>	<p>Type 1.</p>
<p>Complementary features of Type 1 or Type 2 actions:</p>	<p>C.</p>
<p>Communication port:</p>	<p>1 door RS-485 with MODBUS slave communication protocol.</p>
<p>Signal buzzer and alarm:</p>	<p>incorporated.</p>

EVBOX1

Front mounted electrical boards for cold rooms with
single-phase compressor

Installation guide ver. 2.0

PT - 08/15

Code 144BOX1E204

This document is exclusive property of EVCO; EVCO does not
assume any liability regarding possible errors stated.

The customer (manufacturer, installer or final user) assumes
all liability regarding configuration of the device.

EVCO does not take any responsibility about damages coming
by the non-observance of additional information.

EVCO reserves the right to make any change without prejudice
the basic safety and operating features.



EVCO S.p.A.

Via Feltre 81, 32036 Sedico Belluno ITALY

Phone 0437/8422 | Fax 0437/83648

info@evco.it | www.evco.it