

1. Compressor Type

Model	PZ130H1C
Displacement (cc)	13
Nominal voltage limits	220-240V/50Hz
Refrigerant	R600a
Appliance type	Low back pressure
Cooling Type	Static cooling
Expansion Device	Capillary pipe
Motor Type	RSCR

2. Compressor Design Parameter

Refrigerant Oil Type	Alkane base oil
Net mass (oil included)	8.6±0.4kg
Discharge tube (Inner Diameter)	Φ4.91±0.1mm
Suction tube (Inner Diameter)	Φ6.5±0.1mm
Process Tube (Inner Diameter)	Φ6.5±0.1mm
Material for Tube	Copper
Base plate type	European type (170*70)
Water tray holder	Without
Shielding Gas	Negative pressure
Residual impurities	≤50mg
Residual moisture (oil included)	≤100mg
Starting Ability	187V [0.4/0.4 Mpa (abs)](25°C)

3. Electric wiring diagram (RSCR)

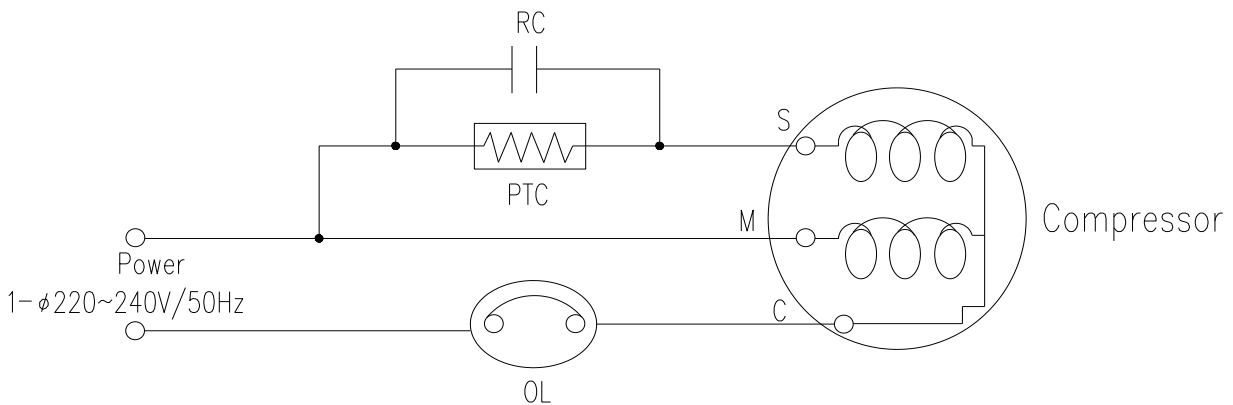

4. Compressor diagram

Accessory assembly diagram (RSCR)

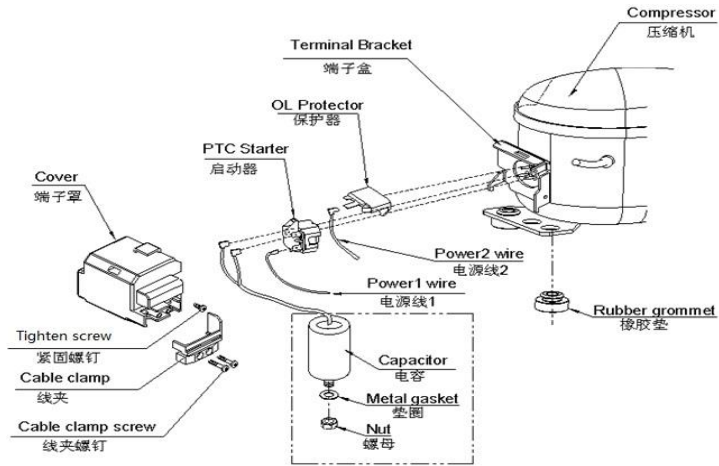

Compressor outline

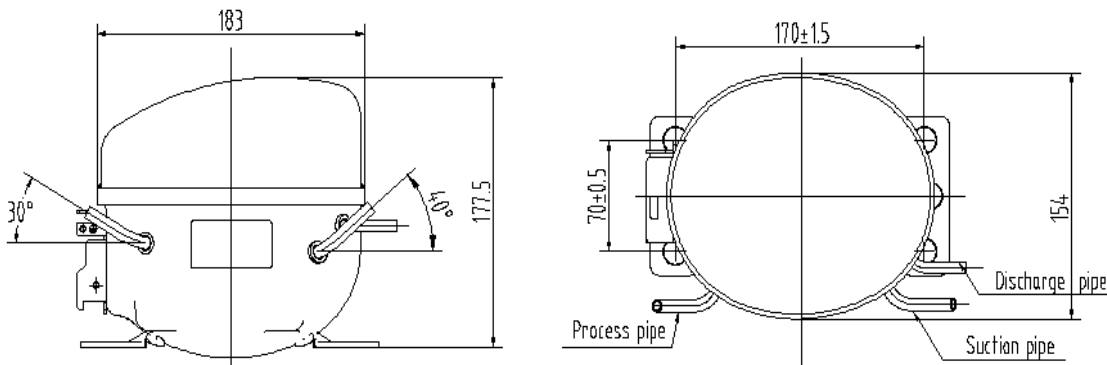

5. Performance Parameters

Displaceme (cm ³)	Test power supply	Capacity (W)	Input power(W)	COP(W/W)	Sound level [dB(A)]	Vibration (m/s ²)	Back Pressure
		≥95%	≤115%	≥95%			
13.0	220V/50Hz	236	138	1.71	≤50	≤0.5	LBP

The test condition:

Test condition (ASHRAE)	LBP			
Evaporating temperature	-23.3℃			
Condensation temperature	54.4℃			
Ambient temperature	32.2℃			
Suction temperature	32.2℃			
Sub cooling temperature	32.2℃			

6. Packing storage and transportation

Amount	96 SETS/PALLETS
Vehicle	Train Or Automobile
Stacking Capacity	2
G.W.	870.2
N.W.	835.2
Cubic Measure m ³	1.1
Dimensions L×W×H(mm)	1100×940×1040

7. Cautions

Ambient temperature	-5~43℃
Evaporating temperature	-35~-10℃
Voltage range	187~254V
Max. pumping pressure	0.92 Mpa
Max. condensing temperature	65℃
Max. winding temperature	130℃
Max. Shell temperature	90℃
Max. discharge temperature	120℃
Flood back amount of refrigerant	No flood back
Intermittent operation item	ON: > 5 minutes, OFF: > 5 minutes or more
Operation cycle times	< 200,000
Angle of slope	within 5°
Pressure difference at start-up	The pressure should be balanced at the high-pressure and low-pressure sides at start-up. If pressure is not balanced, you need to check compressor's starting performance.

8. Delivery List for Components

Number	Name	Specification	Amount	Remark
1	Compressor	PZ130H1C	1	
2	PTC		1	
3	OLP		1	
4	Capacitor		1	
5	Terminal cover		1	
6	Earthing screw		1	
7	Grommet		4	

Remark:

Each component is independently packaged instead of installed on compressor. If there is no figure in AMOUNT column, the corresponding component is not included for this compressor type.

9. Environmental Requirement

Regarding compressor and fitting

- 1、PAHs request : PAHs (II) : BaP content <1ppm、16 kind of PAH(EPA) total quantity <10ppm;
- 2、REACH laws and regulations request: SVHC the limit is smaller than 1000ppm;
- 3、The phthalic acid salt (fat) requests : 18 item of deleterious substance limits request are smaller than 1000 ppm;

10. Compressor operation envelope

