Electronic Control Manual

Commercial XM670K v5.6

Electronic control for commercial refrigeration units



Version 5.6 r9.1

INDEX

1. Description.....	2
2. Technical data	2
3. Remote control VX-760.....	3
4. Remote control LM-660 (XL).....	3
5. Remote control operation.....	4
6. Quick access menu.....	4
7. Time planning / Energy Saving cycle configuration.....	5
8. Operation.....	6
9. Fast cooling.....	6
10. EVI mode (Vapour Injection).....	6
11. Pump-down.....	7
12. Defrost.....	7
13. Condensation control.....	7
14. Communication via local network LAN.....	8
15. External communication.....	9
16. Digital inputs.....	9
17. Parameter list.....	10
18. Alarm messages.....	14
19. Intelligent self-diagnostic functions.....	15

1. Description

The XM670K is an electronic controller for commercial equipment for high, medium or low temperature applications with up to 2 power stages. This electronic regulation can be connected in a small local area network (LAN), and can manage up to 8 different devices, which can operate as individual controllers or following the commands received from the other controllers connected in the local network.

It has 6 relays outputs: compressor, solenoid valve / alarm, defrost (hot gas or heaters), condenser / aircooler fans, evaporator fans, compressor 2 /light. It also has an analogue output An OUT (0-10V), 6 configurable probes and 3 voltage-free digital inputs.

The devices have a HOT-KEY connection port that facilitates the programming of the parameters by means of a data key. The RS485 connection allows intercommunication between the devices and the monitoring and supervision systems of the XWEB series, as well as their control from a PC via ModBus RTU protocol.

2. Technical data

- Container: 8 DIN.
- Connections: screw connectors $\leq 2.5 \text{ mm}^2$ and connectors that can be disconnected.
- Power supply: 230 V.
- Absorption: 9 VA max.
- Probe inputs: 5 configurable probes for NTC/PTC/Pt1000 types.
- Probe input type $4 \div 20 \text{ mA}$ or $0 \div 5 \text{ V}$.
- Digital inputs: 3 voltage-free inputs.
- Relays outputs: total admissible current MAX. 16 A.
 - Solenoid valve / alarm: SPDT relay 8(3) A, 250 Vac.
 - Condenser fans: SPST relay 16(8) A, 250 Vac.
 - Defrost / antifreeze: SPST relay 16(8) A, 250 Vac.
 - Compressor: SPST relay 5(2) A, 250 Vac.
 - Evaporator fans: SPST relay 8(3) A, 250 Vac.
 - Compressor2 / light: SPS relay 8(3) A, 250 Vac.
- Analogue output:
 - Output An OUT: $0 \div 10 \text{ V}$.
- RS485 connection (for ModBUS RTU connection).
- LAN connection.
- Keyboard connection.
- Data storage in non-volatile memory (EEPROM).
- Working temperature: $0 \div 60 \text{ }^\circ\text{C}$.
- Storage temperature: $-25 \div 60 \text{ }^\circ\text{C}$.
- Relative humidity: $20 \div 85\%$ (non-condensing).
- Measuring and adjustment range: PTC probe: $-50 \div 150 \text{ }^\circ\text{C}$;
NTC probe: $-40 \div 110 \text{ }^\circ\text{C}$.
- Resolution: $0.1 \text{ }^\circ\text{C}$: $-19.9 \div 99.9$ or $1 \text{ }^\circ\text{F}$.
- Accuracy at $25 \text{ }^\circ\text{C}$: $\pm 0,1 \text{ }^\circ\text{C} \pm 1 \text{ digit}$.

Sigilus, intarsplit, intarbox, and Waterloo motocondenser (MDM / BDM-S) units

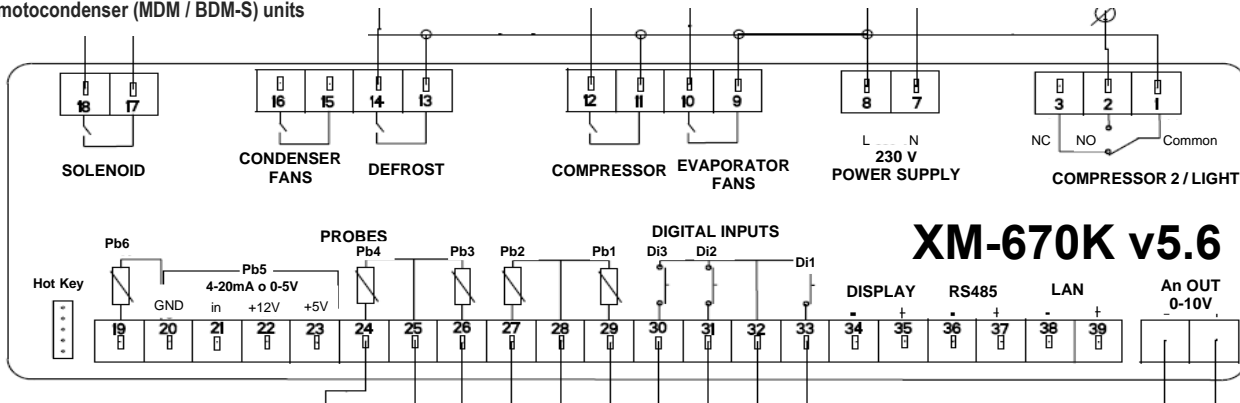

Waterloop motocondenser (MCC / BCC)

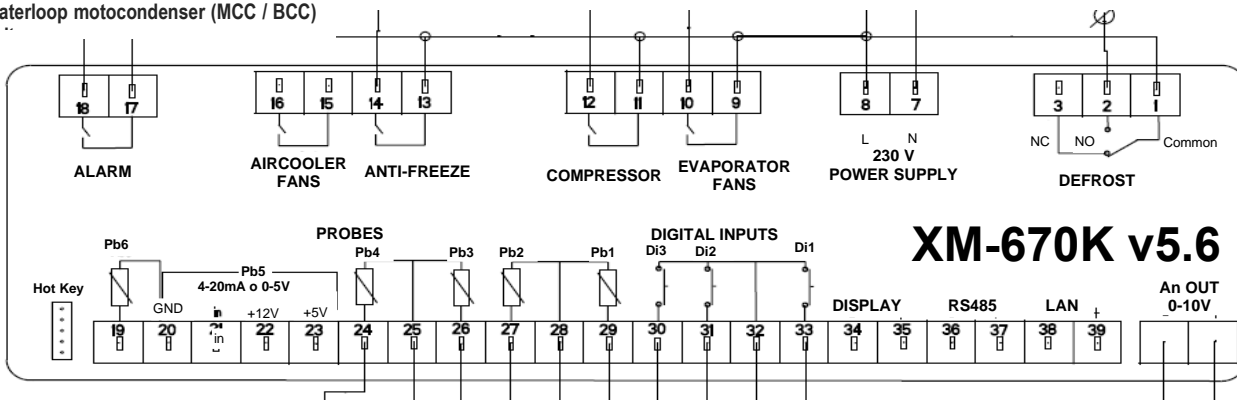







3. Remote control VX-760







It consists of a 3-digit digital display, a 7-button keypad and LEDs indicating operating modes, faults and alarms.



Control keys

	Switches the equipment on or off.
	Switches the cold room light on or off.
	A short press enters the quick access menu. In programming mode it allows you to increment the displayed value or browse the parameter list. Press and hold for 5 seconds to access the SECTION menu.
	In programming mode it is possible to browse the list of parameters or to decrease the displayed value.
	To display and modify the temperature setpoint.
	Press and hold for 3 seconds to manually start a defrost cycle.
	If pressed, the energy saving mode is activated, increasing the value defined in the HES parameter above the setpoint.

Keys combination









 + 	Enter programming mode. Press and hold both buttons for 3 seconds.
 + 	Exit programming mode. Press and hold for 3 seconds to activate the rapid cooling cycle.
 + 	Lock and unlock the keyboard.

4. Remote control LM-660 (XL)







It consists of a 3-digit digital display, an 8-button keypad and LEDs indicating operating modes, faults and alarms.



Control keys

	Display and modify the setpoint temperature. In programming mode, it allows you to select a parameter and confirm its value. Press and hold for 3 seconds when the max. and min. temperature is displayed to clear the record.
	A short press on the key enters the quick access menu. Pressing the key for more than 5 seconds activates access to the SECTION menu. In the parameter list, scroll through the parameters and increase their value.
	In the parameter list, allows to scroll through the parameters and increase their value.
	Press and hold for 3 seconds to start the defrost cycle.
	Switches the cold room light on or off. If the regulation governs a second compressor, this key is disabled.
	If pressed, the energy saving mode is activated, increasing the value defined in the HES parameter above the setpoint.
	Key disabled.
	Press and hold for 6 seconds to switch the equipment on or off.

Keys combination

 + 	Lock and unlock the keyboard. When the keyboard is locked, only the key  can be used.
 + 	Enter programming mode. Press and hold both buttons for 3 seconds.
 + 	Exit programming mode. Press and hold for 3 seconds to activate the fast-cooling cycle.

5. Remote control operation

Illuminated warning lights

The function of each icon and LED is described in the following table:

LED	STATUS	MEANING
	ON	Active compressor.
	FLASHING	Compressor anti-short cycle. Open safety chain (pressure switches, klixon fans, compressor thermal relays...)
	ON	The equipment is defrosting.
	FLASHING	Drip time after defrosting.
	ON	Active alarm. See section 17.
	ON	Active Energy Saving (Energy Saving). See section 7.
	ON	Active fans.
	FLASHING	Drip time. Fan start-up delay after defrosting.
AUX	ON	Warning light disabled
°C/°F/Bar/PSI	ON	Units of measurement.
°C/°F/Bar/PSI	FLASHING	Active parameter list.
	ON	The controller is working in global "ALL" mode. See section 14.
	FLASHING	Access to remote device connected to the LAN. See section 14.

Remote control functions

To switch the equipment on or off.-

- Switch on the equipment. Press the key , the controller will switch on showing the cold room temperature on the display.
- Switch off the equipment. Press the key and "OFF" will be displayed. In this situation all relays will be deactivated as well as the regulation; if a monitoring system is connected, it will not register any valid data and no alarm situation.



When the equipment is switched off, the cold room light can be switched on and off by pressing its key on the remote control.

To enter the quick access menu.-

- Press the key .
- The first label "An" appears. By pressing the keys or you can scroll through the menu.

To display and modify the setpoint temperature.-

- Press the key and the setpoint will be displayed.
- The unit of measurement warning light shall start flashing.
- Press the keys or to modify the value.
- Press the key to save the setpoint temperature.

To start a manual defrost -

- Press the key for 3 seconds.

To access the Pr1 user parameters list.-

- Press the keys and for a few seconds (the unit of measurement warning light shall start flashing),
- The display will show the first parameter in the list.

To access the Pr2 protected parameters list.-

- Access the user parameters list,
- Select the "Pr2" parameter and press ,
- The message "PAS" followed by "0 -" shall be displayed.
- Press the keys or to change the flashing digit and confirm the value by pressing , until the access code is entered.

Note: Each parameter in Pr2 can be moved to Pr1 or vice versa by simultaneously pressing the keys and . When a parameter is in Pr1 the temperature decimal point will be on.

To modify a parameter.-

- Enter the list of parameters.
- Select the desired parameter with the keys or and press to display its value.
- Press the keys or to change the value.
- Press to save the new value and move on to the next parameter.
- To exit parameters press and or wait 15 seconds.

To lock the keyboard.-

- Press the keys and for 3 seconds.
- The message "PoF" shall be displayed and only the setpoint, max. and min. temperature records and switching the cold room light on or off shall be allowed.
- To unlock the keypad, press the keys and for 3 seconds, "Pon" will appear on the display for a few moments.

6. Quick access menu

Press the key to enter the quick access menu. Use the keys or to scroll through the menu.

In this menu you can view the instantaneous reading of the different temperature probes, view the status of the digital inputs and relay outputs and consult the number of devices connected in LAN (if any), as well as the Adr address of the device itself.

To display the status of the digital inputs or relay outputs, simply navigate through the menu to the desired value and press the key , then press and hold down the key to display the configured value.

For example, if the compressor is running, the value associated with this digital input (in1) will appear **ON**, if we leave the key pressed it will show the value **CPR** (compressor).

Below is an overview of the parameters that appear in this quick access menu and their meaning:

QUICK ACCESS MENU			
CODE	DESCRIPTION	CONFIGURATION	
		SIGILUS, INTARSPLIT, INTARBOX AND WATERLOOP (MDM/BDM-S)	WATERLOOP (MCC/BCC)
An	Instantaneous value of the analogue output.		
dP1	Display of the instantaneous value of the probe 1.*	Cold room temperature probe	
dP2	Display of the instantaneous value of the probe 2.*	Defrost temperature probe	
dP3	Display of the instantaneous value of the probe 3.*	Liquid temperature probe	Condensation temperature probe
dP4	Display of the instantaneous value of the probe 4.*	Suction temperature probe	Antifreeze heater temperature probe
LSn	Display of the number of devices connected in LAN.		
LAn	Identifies the serial address of the equipment on the local LAN.		
in1	Digital input status display 1.	High pressure switch	
in2	Digital input status display 2.	Low pressure switch	N/A
in3	Digital input status display 3.		Door micro-switch
oU1	Display of relay 1 output status.	Compressor relay output (CPr)	
oU2	Display of relay 2 output status.	Defrost relay output (dEF)	Antifreeze relay output (AUS)
oU3	Display of relay 3 output status.	Evaporator fan relay output (FAn)	
oU4	Display of relay 4 output status.	Condenser fan relay output (Cnd)	Aircooler fan relay output (Cnd)
oU5	Display of relay 5 output status.	Cold room light relay output (LiG)	Defrost relay output (dEF)
oU6	Display of relay 6 output status.	Liquid solenoid relay output (SOL)	Alarm relay output (Alr)

* If Err appears on the display when a probe value is displayed, the probe is out of range or not connected.

Note: If a probe is disabled, its code will not appear in the menu.



7. Time planning / Energy Saving cycle configuration



Before the start-up of the equipment, it is recommended to configure the parameters of this section.

The configuration of the energy saving cycle allows you to set a higher set point temperature than usual in order to reduce the energy consumption of the equipment in specific periods of time (weekends/nights when there is no product rotation, few cold room openings, etc.). During the energy saving cycle, the set point is increased with the value contained in "HES" so that the operating set point is SET+HES. Naturally, the operating set point must comply with the rules governing product preservation.

Before setting the time schedule, it shall be necessary to activate the internal clock by changing the parameter "CbP" to Y.

- To access the RTC time planning menu, press the keys **SET** and  for 3 seconds (the unit of measurement indicator will start flashing) and RTC will appear. If it does not appear, use the keys  or  until you find the RTC parameter and press the key **SET**.
- Description of the parameters of the RTC submenu.

	PARAMETER	RANGE	DESCRIPTION
Internal clock	CbP	n - Y	Enable internal clock.
	Hur	0 ÷ 23 h	Current hour for the internal clock.
	Min	0 ÷ 59 min	Current minutes for the internal clock.
	dAY	SUn - Mon - tUE - UEd - tHU - Fri - SAT	Current day of the week for the internal clock: Sunday, Monday, Tuesday, Wednesday, Thursday, Friday and Saturday, respectively.
Internal calendar	Hd1	SUn - Mon - tUE - UEd - tHU - Fri - SAT - nu	First public holiday of the week. nu: do not assign any day.
	Hd2	SUn - Mon - tUE - UEd - tHU - Fri - SAT - nu	Second public holiday of the week. nu: do not assign any day.
	Hd3	SUn - Mon - tUE - UEd - tHU - Fri - SAT - nu	Third public holiday of the week. nu: do not assign any day.
Energy Saving cycle	ILE	0.0 ÷ 23.5 (resolution 30min)	Start time of the energy saving cycle in the weekday period.
	dLE	0.0 ÷ 24.0 (resolution 30 min)	Duration of the energy saving cycle during working days.
	ISE	0.0 ÷ 23.5 (resolution 30min)	Start time of the energy saving cycle for public holidays.
	dSE	0.0 ÷ 24.0 (resolution 30min)	Duration of the energy saving cycle during public holidays.
	HES	[-30.0 ÷ 30.0] °C	Temperature set point increase during the energy saving cycle.

If no energy saving cycle is to be configured, the parameters must have the following settings:

Hd1=nu; Hd2=nu; Hd3=nu; iLE=0.0; dLE=0.0; iSE=0.0; dSE=0.0; HES=0.0

- Example of time scheduling with energy saving cycle (Energy Saving).

It is assumed that the following hourly planning is to be carried out, during which the setpoint is increased by 4 °C.

HES= 4 °C

Saturdays and Sundays are considered public holidays.

Hd1= SAT

Hd2= SUN

Hd3= nu

The energy saving cycle on weekdays starts at 11:00 a.m. and ends at 17:00 p.m. (6 hours).

iLE= 11.0

dLE= 6.0

During the weekend (public holidays) the energy saving cycle starts at 7:00 a.m. and ends at 00:00 p.m. (17 hours). Therefore:

iSE=7.0

dSE=17.0

	0	1	2	3	4	5	6	7	8	9	10	11	12	13	14	15	16	17	18	19	20	21	22	23
L																								
M																								
X																								
J																								
V																								
S																								
D																								

Normal operating cycle
 Energy saving cycle

8. Operation

A setpoint temperature is set for the cold room. When the temperature in the cold room is higher than the SET setpoint plus a "Hy" differential, the refrigeration cycle starts and stops when the cold room temperature is equal to the setpoint.

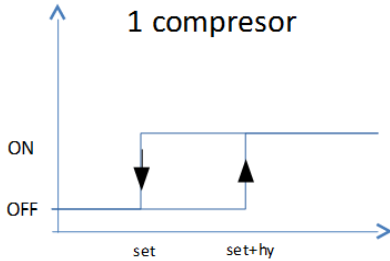

In this operating mode, the digital display of the control unit shows the temperature of the cold room. The setpoint temperature can be displayed by pressing the key **SET** and its value can be changed using the keys and .

To protect the compressor against successive starts and stops, the regulation incorporates an anti-short cycle timer.

During the cooling cycle, the solenoid valve is activated whenever the compressor is activated. If the low pressure switch opens (pressure outside the design operating limits of the equipment), the solenoid valve is activated to increase the compressor suction pressure in an attempt to reset the low pressure switch in order to continue cooling production.

Shutdown by digital input 1 opening (high pressure switch): If an opening number of the digital input equal to the parameter "nPS" is reached within a time interval "d1d", the alarm buzzer is triggered, the message "HP" is displayed, the compressor is switched off and the regulation is blocked. The unit does not try to start again. The electronic regulation must be switched off and on again to reset this alarm.

Shutdown by digital input 2 opening (low pressure switch): On activation of the low-pressure switch, the compressor automatically switches off and activates the short-circuit protection time delay (parameter "AC"), after the time interval "AC" has elapsed, the pressure switch is reset by opening the solenoid valve. If an opening number of the digital input equal to the parameter "nPS" is reached within a time interval "d2d", the alarm buzzer is triggered, "LP" is displayed, the compressor is switched off and the regulation is blocked. This alarm "LP" is also generated by a pressure switch opening (without reset) during a time interval "d2d". The unit does not try to start again. The electronic regulation must be switched off and on again to reset this alarm.

Security features: The control allows an additional digital input to be enabled. The common digital input is used as an additional digital input. The security line is associated with this additional digital input. When activated, the alarm "PCo" is displayed on the screen and blocks all outputs, then it automatically alarms with a maximum number of retries "nPS". If you open the security line "nPS" times the alarm "PCb" is displayed and the device is blocked.

Equipment with two compressors

The operation in units with a second compressor is as follows. When the cold room temperature is higher than the SET setpoint plus a "Hy" differential, the first compressor starts up. If the cold room temperature is higher than the setpoint SET + "Hy" + "Hy", the second compressor starts up. The first compressor stops when the cold room temperature is SET + "Hy" and the second compressor stops when the cold room temperature is the setpoint temperature.

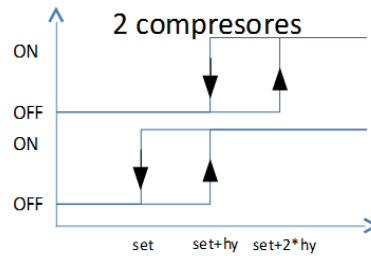

The electronic control alternately rotates the operation of the compressors to spread the working time.

If the high condensing temperature alarm "CSd" is generated, the electronic control stops the second compressor to try to lower the condensing pressure.

When the electronic regulation controls a second compressor, the cold room light output is not available.

9. Fast cooling

To activate the continuous fast cooling mode, it will be necessary to press the keys **SET** + for 3 seconds. In this way the unit will temporarily change the set point of the unit, the unit will start and stop when the new set point assigned in the "CCS" parameter is reached. When this mode is activated, the icon will flash slowly. During this process it is not possible to activate defrost either by time or manually.

10. EVI mode (Vapour Injection)

When you have a compressor with EVI (vapour injection) for low temperature, you can control the activation of this injection by means of the "SEU" parameter. If the cold room temperature is lower than the value indicated in "SEU" and the compressor is on, the relay will be active. If the temperature is higher than "SEU" plus the differential "Hy" the relay will be inactive. One of the relay outputs must be configured as UAP.

In case of 2 compressors, the EVI mode relay output only operates when the first compressor is running. Even if there is compressor rotation, the EVI will only operate with the first compressor.

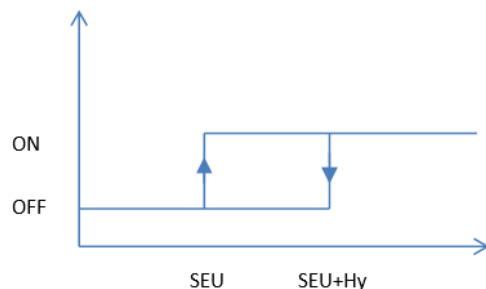

11. Pump-down

With this function, the control incorporates a delay in compressors shutdown when the liquid solenoid valve closes, so that the refrigerant stored in the discharge is collected in the suction line of the compressor. When one of the compressors starts to run again, the solenoid valve is opened beforehand to break the vacuum created in the suction line.

To configure the pump-down mode, it is necessary to set the parameter "PdC" to **tiM**, pump-down active by time. If the parameter is set to **nu** it will be deactivated. The parameters "MPt" (maximum time the compressor remains active after the solenoid valve closes) and "LPt" (maximum time the solenoid valve remains open before the compressor starts) will be used to manage the compressor off-delay and start-up delay (once the solenoid valve opens) respectively during pump-down mode.

12. Defrost

Defrost can be started by manual activation (by pressing the key  for 3 seconds), automatic defrost (when the interval set in parameter "idF" expires), smart defrost (the expiry time only counts if the evaporating temperature is lower than indicated in

parameter "SdF"), or by a defrost start command from the local LAN (synchronised defrost, for this case see section 14).

The unit is factory set to evaporator temperature controlled defrost mode. In this mode, defrosting ends when the evaporator temperature reaches a value determined by parameter "dtE", or after the time set by parameter "MdF" has elapsed. After defrosting, the unit remains stopped for the drip-off time (determined by parameter "Fdt") to allow the evaporator coil to drain.

The unit has been configured in the factory so that the fans remain stopped during defrosting (except in units with air defrosting) (configurable by parameter "FnC").

After defrosting and during start-up of the refrigerant cycle, the internal fan remains stopped (except for units with air defrosting) for the time set by the "Fnd" parameter.

In order to adapt the defrost cycle to the needs of the installation, it has been established the possibility of setting a calendar and defrost start times of up to 6 cycles per day, allowing to differentiate between working days and holidays.

The defrost parameters are set in a similar way as in section 7.

	PARAMETER	RANGE	DESCRIPTION
Internal clock	CbP	n - Y	Enable internal clock.
	Hur	0 ÷ 23h	Current hour for the internal clock.
	Min	0 ÷ 59min	Current minutes for the internal clock.
	dAY	SUn - Mon - tUE - UEd - tHU - Fri - SAT	Current day of the week for the internal clock: Sunday, Monday, Tuesday, Wednesday, Thursday, Friday and Saturday, respectively.
Internal calendar	Hd1	SUn - Mon - tUE - UEd - tHU - Fri - SAT - nu	First public holiday of the week. nu: do not assign any day.
	Hd2	SUn - Mon - tUE - UEd - tHU - Fri - SAT - nu	Second public holiday of the week. nu: do not assign any day.
	Hd3	SUn - Mon - tUE - UEd - tHU - Fri - SAT - nu	Third public holiday of the week. nu: do not assign any day.
Defrost cycle	Ld1	nu - 0.0 ÷ 23.5 (resolution 30min)	Start time of first defrost on working day.
	Ld2	nu - 0.0 ÷ 23.5 (resolution 30min)	Start time of second defrost on working day (minimum Ld1).
	Ld3	nu - 0.0 ÷ 23.5 (resolution 30min)	Start time of third defrost on working day (minimum Ld2).
	Ld4	nu - 0.0 ÷ 23.5 (resolution 30min)	Start time of fourth defrost on working day (minimum Ld3).
	Ld5	nu - 0.0 ÷ 23.5 (resolution 30min)	Start time of fifth defrost on working day (minimum Ld4).
	Ld6	nu - 0.0 ÷ 23.5 (resolution 30min)	Start time of sixth defrost on working day (minimum Ld5).
	Sd1	nu - 0.0 ÷ 23.5 (resolution 30min)	Start time of first defrost on public holidays.
	Sd2	nu - 0.0 ÷ 23.5 (resolution 30min)	Start time of second defrost on public holiday (minimum Sd1).
	Sd3	nu - 0.0 ÷ 23.5 (resolution 30min)	Start time of third defrost on public holiday (minimum Sd2).
	Sd4	nu - 0.0 ÷ 23.5 (resolution 30min)	Start time of fourth defrost on public holiday (minimum Sd3).
	Sd5	nu - 0.0 ÷ 23.5 (resolution 30min)	Start time of fifth defrost on public holiday (minimum Sd4).
	Sd6	nu - 0.0 ÷ 23.5 (resolution 30min)	Start time of sixth defrost on public holiday (minimum Sd5).

13. Condensation control

The XM670K electronic controller incorporates a digital condensing temperature control. The condensation control can be of various types (depending on equipment):

- All/nothing condensation control. The control acts on the stop/start of the condenser fan depending on the reference probe for condenser control defined in parameter "CnP". A condenser set point parameter "CSP" and a condenser differential are defined in parameter "CHy". The fan will be activated when the value defined in parameter "CSP" + "CHy" is reached. When the condenser value reaches the value set in "CSP" the fan will be deactivated.

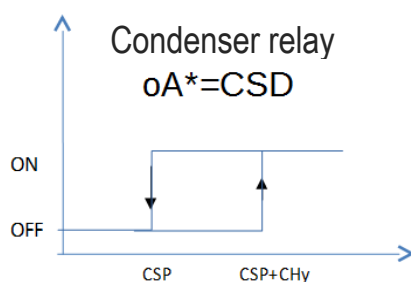

- Proportional condenser control by voltage variation of the fans. This speed control is carried out via the analogue output (An Out). The control modulates the condenser fan speed according to the condenser probe reading defined in the "CdP" parameter. For condenser regulation, it is necessary to select the **Cnd** value in the "trA" parameter. The condensation set point is defined by the value of the "SdP" parameter, and the fan proportional band parameter "PbA" sets the temperature band in which the fan varies its speed from 0% (temperature equal to "SdP") and 100% (temperature equal to "SdP" + "PbA").

If an offset for the start of the proportional ramp is to be introduced, it can be defined in the "ASr" parameter. The "AMi" parameter defines the minimum value (%) at which the fans are to be activated, while the "AMA" parameter defines the maximum value (%) at which the fans are to operate.

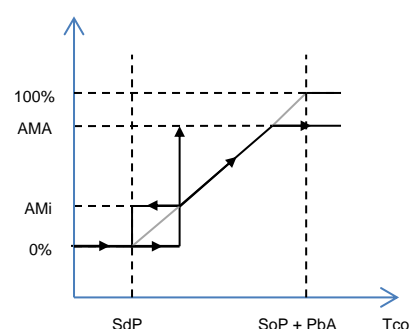

14. Communication via local network LAN

The communication between devices via LAN (Local Area Network) allows several devices to be operated with a single control display, as well as the synchronisation of various functions.

To connect the equipment to the LAN network, use shielded cable to connect negatives to negatives (terminals 38 on the XM670K board) and positives to positives (terminals 39 on the XM670K board) as shown in the following image:

If the LAN is properly connected, the LED next to the Hot Key port on the XM670K board will light green. This LED flashes if the LAN connection is misconfigured.



Each XM670K electronic controller must have a different address number ("Adr" parameter).
If a ModBus connection exists at the same time as the LAN, the "Adr" is also the ModBus address.

The maximum interconnection distance between equipment is 30 metres.

The LAN supports a maximum of 8 connected devices.

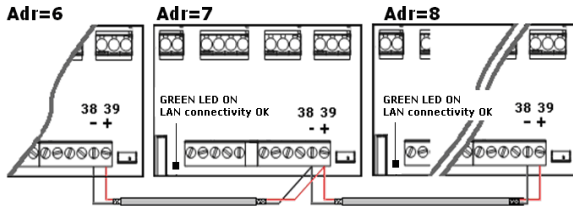

Section menu (Equipment connected via LAN)

This menu allows the user to access the functions for LAN management.

It is possible to control both the local equipment and other remote equipment connected to the LAN network with a single control command. The possibilities are:

LOC: The keyboard acts only on the equipment to which it is physically connected.

ALL: Commands given via the keyboard are sent to all equipment present on the LAN.

SE+Device N°: Displays the device number of the LAN network (Adr).



NOTE: When the "ALL" mode is selected, the "defrost start" and "power save" signals of the local equipment will be executed on all equipment in the LAN.

To change these functions, follow the instructions below:

1. Press the key for more than 6 seconds, and the label "SEC" will appear.
2. Press **SET**, and with the arrow keys or select the section to be controlled, which can be LOC (local), ALL (all), or SE+ Device N° (remote device). If ALL is selected, the symbol will light up, and if a remote device is selected, the symbol will flash.
3. Press **SET** to confirm and exit.

Notes:

- To define the LAN address of each device (they must be different), this must be done by changing the value of the "Adr" parameter, and always working in local mode.
- LAN administration, probe configuration, service and other parameters cannot be modified in ALL mode.
- If any of the equipment connected to the LAN is switched off or if the polarity of the network is not respected, a "nod" alarm will appear.
- If any of the equipment connected to the LAN network has an active alarm, the control command will display the message **AS1, AS2, AS3, AS4, AS5, AS6, AS7** or **AS8**; always referring **AS1** to the local device. For this reason it is advisable to assign the value **Adr=1** to the equipment where the control command will be physically connected.
- To display the alarm message of the equipment, go to the section menu and select **SE+Device n°**, in this way the keypad acts on the selected equipment and displays the active alarm of the device. For example, if an alarm is active in device number 2 (**Adr=2**) of the LAN network, the keypad will display the **AS2** alarm and it will be necessary to go to the section menu and select **SE2** for the keypad to act on that device and display the alarm code (PA, HA,).

Synchronisation between devices connected via LAN local area network

When several units are connected via LAN, the XM670K controller offers different synchronisation possibilities between them, especially when the units are installed in the same refrigeration room. These synchronisation possibilities are as follows:

SYNCHRONISATION OF LAN NETWORK EQUIPMENT	
LMd	Synchronisation of defrost start. <ul style="list-style-type: none"> • LMd=y → When one of the devices starts defrost, the defrost start command will automatically be sent to all devices connected to the LAN. • LMd=n → The unit does not send the defrost command to the other units.
dEM	End of defrost synchronisation. <ul style="list-style-type: none"> • dEM=y → The end of defrost is synchronised. All units wait for the rest of the units to finish defrosting before starting refrigeration again. Once the last evaporator reaches the end of defrost temperature "dTe" or its maximum defrost time "MdF" has expired, the drip-off time "Fdt" is counted and once this time has elapsed, refrigeration is started again. • dEM=n → The end of defrost is independent.
LSP	Synchronisation of the set point temperature. <ul style="list-style-type: none"> • LPS=y → Changing the set point on the local unit will also update it on the other units connected to the LAN. • LPS=n → The set point is only modified in the local equipment.
LdS	Display synchronisation. <ul style="list-style-type: none"> • LdS=y → The value shown on the display of the local device is also sent to the other devices connected to the LAN. • LdS=n → The value shown on the display of the local unit was not sent to the other units in the LAN.
LOF	Stop/Start Synchronisation. <ul style="list-style-type: none"> • LoF=y → The Stop/Start command given by the local equipment acts on the other equipment connected to the LAN. • LoF=n → The Stop/Start command given by the home team acts only on the home team.
LLi	Synchronisation of cold room light switch-on (only units with a single compressor). <ul style="list-style-type: none"> • LLi=y → The cold room light ON command given by the local unit also acts on the other units connected to the LAN. • LLi=n → The cold room light ON command only acts on the local device.
LES	Energy Saving synchronisation (Energy Saving). <ul style="list-style-type: none"> • LES=y → The energy saving command given by the local device also acts on the other devices connected to the LAN. • LES=n → The energy saving command given by the local device does not act on the other devices connected to the LAN.
LAU	Auxiliary relay synchronisation <ul style="list-style-type: none"> • LAU=y → The auxiliary relay command given by the local unit also acts on the other units connected to the LAN. • LAU=n → The auxiliary relay command only acts on the local equipment.
LSd	Remote probe display. <ul style="list-style-type: none"> • LSd=y → The value measured by a remote probe (sent from a section with parameter LdS = 1) will be displayed on the local control. • LSd=n → The value measured by the remote probe is not displayed on the local control.
StM	LAN cold synchronisation <ul style="list-style-type: none"> • StM=y → The cooling command given on the local unit also acts on the other units connected to the LAN. • StM=n → The cooling command only acts on local equipment.

15. External communication

It is possible to connect the unit to an RS485 network via ModBUS-RTU protocol compatible with the XWEB monitoring system.

For ModBus connection of the devices, connect negatives to negatives (RS485 - terminal) and positives to positives (RS485 + terminal).



Each XM670K electronic controller must have a different address number ("Adr" parameter).
If a ModBus connection exists at the same time as the LAN, the Adr is also the ModBus address.

If several devices are connected in a LAN network, connect the RS485 connection to only one of them as shown in the following picture:

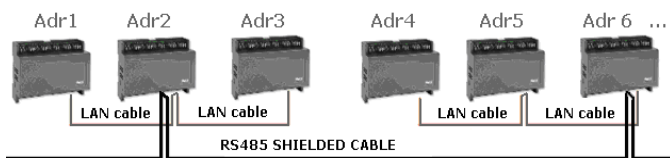

There is also a TTL input that can be used to download data from a hot key.

16. Digital inputs

The XM670K controller supports up to 3 voltage-free digital contact inputs.



Opening one of the digital inputs will cause the indicator to flash. ❄️

High pressure switch and safety elements (i1F=PAL). Digital input 1

Shutdown by digital input 1 opening (high pressure switch): If an opening number of the digital input equal to the parameter "nPS" is reached within a time interval "d1d", the alarm buzzer is triggered, the message "HP" is displayed, the compressor is switched off and the regulation is blocked. The unit does not try to start again. The electronic regulation must be switched off and on again to reset this alarm.

Low pressure switch (i2F=PBL). Digital input 2

Only the low-pressure switch is connected to this digital input.

Shutdown by digital input 2 opening (low pressure switch): On activation of the low-pressure switch, the compressor is automatically switched off and the solenoid valve opens. If a digital input opening number equal to the parameter "nPS" is reached within a time interval "d2d", the alarm buzzer is triggered, "LP" is displayed, the compressor is switched off and the regulation is blocked. This alarm "LP" is also generated by a pressure switch opening (without reset) during a time interval "d2d". The unit does not try to start again. The electronic regulation must be switched off and on again to reset this alarm.

Security features

The control allows an additional digital input to be enabled. The common digital input is used as an additional digital input. The security line is associated with this additional digital input. When activated, the alarm "PCo" is displayed on the screen and blocks all outputs, then automatically resets with a maximum number of retries "nPS". If you open the security line "nPS" times the alarm "PCb" is displayed and the device is blocked.

Various uses. Digital input 3

This digital input can have one of the following configurations (parameter "i3F").

- **Generic alarm (EAL):** If the digital input is activated after a delay defined by parameter "d3d", an alarm is generated and the message "EA" is displayed. The status of the outputs is not modified. The alarm is automatically reset as soon as the digital input is deactivated.
- **Door open (dor):** Indicates to the device that the cold room door is open. When the door is opened, the compressor and fans regulate based on the value of the "OdC" parameter:

PARAMETER	VALUE	ACTION
OdC	no	Fans and compressor do not interrupt their operation.
	Fan	Fans off
	CPr	Compressor off
	F_C	Compressor and fans off

After the time defined in parameter "d3d", the open door alarm is activated and the message "dA" is displayed. The alarm is automatically reset as soon as the digital input is deactivated.

If the door is not closed after a time defined in the "rrrd" parameter, the electronic control continues the cooling cycle.

In the open door situation, the high and low cold room temperature alarms are disabled.

- **Defrost activation (DEF):** Starts a defrost cycle if conditions are met.
- **Auxiliary activation (AUS):** When the digital input is activated, the auxiliary relay is also activated. When the digital input is deactivated, the auxiliary relay is also deactivated.
- **Light activation (LIG):** Allows to activate or deactivate the cold room light output with the activation of the digital input (only allowed in devices with one compressor).
- **Remote Stop/Start (ONF):** When the digital input is activated, the equipment is switched off. When the digital input is deactivated, the equipment is switched on.
- **Energy Saving activation (ES):** Enables/disables the energy saving cycle (see section 7). The energy saving cycle runs continuously as long as the digital input remains active.
- **Holiday function activation (HDY):** Enables or disables the holiday function.

17. Parameter list

PARAMETER	DESCRIPTION	RANGE	SIGILUS, INTARSPLIT, INTARBOX and WATERLOOP (MDM/BDM-S)			WATERLOOP (MCC/BCC)		LIST	
			High Temp.	Medium Temp.	Low Temp.	Medium Temp.	Low Temp.		
REGULATION	rtc	Time clock menu access.						Pr1	
	SEt	Temperature setpoint.	[-20.0 ÷ 12.0] °C	12.0 °C	0.0 °C	-20.0 °C	0.0 °C	-20.0 °C	
	Hy	Differential for temperature regulation.	[0.1 ÷ 25.5] °C	2.0 °C			2.0 °C		Pr1
	LS	Setpoint temperature lower limit.	[-55.0 °C ÷ Set]	5.0 °C	-5.0 °C	-25.0 °C	-2.0 °C	-24.0 °C	Pr2
	US	Setpoint temperature upper limit.	[Set ÷ 150.0 °C]	18.0 °C	10.0 °C	-15.0 °C	10.0 °C		Pr2
CONDENSER FANS	SEU	EVI (vapour injection) activation setpoint.	[-55.0 ÷ 150.0] °C	-5.0 °C			-7.0 °C		Pr2
	dST	Floating setpoint. Set point.	[-55.0 ÷ 150.0] °C	20 °C			20.0 °C		Pr2
	dSb	Floating setpoint. Band.	[0.1 ÷ 25.5] °C	10 °C			10.0 °C		Pr2
	dSH	Floating setpoint. Differential.	[-12 °C ÷ 12 °C]	10 °C			10.0 °C		Pr2
REGULATION	dSP	Floating setpoint. Probe selection.	nP - P1 - P2 -...- P6	nP			nP		Pr2
	odS	Time during which the activation of functions other than cold room light is not permitted from power-up.	0 ÷ 255 (min)	1 min			1 min		Pr2
	CCo	Compressor rotation configuration: Sequential - Alternative.	SEc - ALt	ALt			ALt		Pr2
	AC	Anti-short cycle protection: Minimum time interval between compressor stop and start.	0 ÷ 60 (min)	4 min			4 min		Pr2
	AC1	Activation delay on the second compressor.	0 ÷ 255 (s)	1 s			1 s		Pr2
	CCt	Duration of the continuous fast cooling cycle.	0.0 ÷ 24.0 (h. min)	0.3 (0h 30min)		2.3 (2h 30min)	0.3 (0h 30min)		Pr1
	CCS	Set point temperature for continuous rapid cooling cycle.	[-55.0 ÷ 150.0] °C	0.0 °C			0.0 °C		Pr1
	Con	Compressor time ON in the event of a Pb1 probe failure.	0 ÷ 255 (min)	15 min			15 min		Pr2
	CoF	Compressor time OFF in the event of a Pb1 probe failure.	0 ÷ 255 (min)	15 min			15 min		Pr2
	CF	Temperature measurement units.	°C - °F	°C			°C		Pr1
	rES	Accuracy integer/decimal temperature (only for CF = °C): in (integer) = 1 °C; de (decimal) = 0.1 °C.	dE - in	dE			dE		Pr1
	Lod	Probe to be shown on the display: P1-P6=probe; tEr= thermostatisation virtual probe; dEF= defrost virtual probe.		P1			N/A		Pr2
	rEd	Remote display: default display.	nP - P1 - P2 -...- P6	P1			P1		Pr2
	DEFROST	dMo	Defrost mode: single (SnG); single with 2 probes (S2P); double (dou)	SnG - S2P - dou	SnG			SnG	
dPA		Defrosting A probe.	nP - P1 - P2 -...- P6	P2			P2		Pr2
dPb		Defrosting B probe.	nP - P1 - P2 -...- P6	nP			nP		Pr2
tdF		Type of defrost. (Do not modify) : EL=Electric; EIt: thermostatic electric defrost; in=inversion of cycle.	EL - EIt - in	EL	Electric defrost: EL Gas defrost: in		in		Pr2
EdF		Defrost activation mode: rC: internal clock; in: fixed counter time expiry; Sd: Smart defrost.	rC -in -Sd	in			in		Pr2
SdF		Temperature setpoint for Smart defrost.	[-55.0 ÷ 150.0] °C	0.0 °C			0.0 °C		Pr2
Hyr		Defrost heater activation differential. Only affects if the defrost is set to thermostatic type (tdf=EIt).	[0.1 ÷ 25.5] °C	2.0 °C			2.0 °C		Pr2
tod		Time to end of defrost. Only affects if the defrost is set to thermostatic type (tdf=EIt).	0 ÷ 255 (min)	2 min			2 min		Pr2
dtE		Temperature end of defrost of first evaporator.	[-55.0 ÷ 50.0] °C	15.0 °C	Electric defrost: 8.0 °C Gas defrost: 20.0 °C		20.0 °C		Pr1
dtS		Temperature end of defrost of second evaporator.	[-55.0 ÷ 50.0] °C	8.0 °C	Electric defrost: 8.0 °C Gas defrost: 20.0 °C		20.0 °C		Pr1
idF		Interval between defrosts.	0 ÷ 255 (h)	3 h		Elec. def.: 4 h Gas def.: 3 h	2 h		Pr1
dSd		Defrost start delay.	0 ÷ 255 (min)	0 min			0 min		Pr2
MdF		Maximum defrost duration of the first evaporator.	0 ÷ 255 (min)	15 min	Electric defrost: 30 min Gas defrost: 45 min		45 min		Pr1
MdS		Maximum defrost duration of the second evaporator.	0 ÷ 255 (min)	20min	Electric defrost: 20 min Gas defrost: 45 min		45 min		Pr1
Fdt		Time from end of defrost to start of compressor (drip time).	0 ÷ 255 (min)	0 min	2 min	3 min	2 min	3 min	Pr2
dFd		Display during defrost: rt=actual temperature; it=temperature at start of defrost; Set=setpoint temperature; dEF=text "dEF"	rt - it - Set - dEF	it			it		Pr2
dAd		Time after defrost to show actual cold room temperature.	0 ÷ 255 (min)	15 min			15 min		Pr2
dPo	Defrost immediately after start-up.	n - Y	no			no		Pr2	
dAF	Defrost cycle delay at the end of fast mode.	0.0 ÷ 24.0 (h. min)	2.0 (2h 0min)			2.0 (2h 0min)		Pr2	



PARAMETER	DESCRIPTION	RANGE	SIGILUS, INTARSPLIT, INTARBOX and WATERLOOP (MDM/BDM-S)			WATERLOOP (MCC/BCC)		LIST		
			High Temp.	Medium Temp.	Low Temp.	Medium Temp.	Low Temp.			
ddt	Defrost self-diagnosis "dFA". Temperature increases during defrost.	[0.1 ÷ 25.5] °C	0.1 °C			0.1 °C		Pr1		
	Defrost self-diagnosis "dFA". Time for defrost temperature control. If ddF=0, the alarm "dFA" is cancelled.	0.0 ÷ 30.0 (min)	0.0 (0 min. 0 s)			0.0 (0 min. 0 s)		Pr1		
	Self-diagnostic defrost "dFL". Maximum number of consecutive defrosts completed by time instead of temperature. If dFL=0 the warning is cancelled.	[0 ÷ 15]	0	5		0		Pr1		
EVAPORATOR FANS	FnC	Operation of evaporator fans: With compressor (C) or continuously (O) and during defrost (y=yes / n=no).	C-n , C-y , O-n , O-y	C-y	C-n		C-n	Pr1		
	Fnd	Delayed activation of evaporator fans after defrost.	0 ÷ 255 (min)	0 min	3 min	4 min	0 min	Pr2		
	FSt	Evaporator probe temperature above which the fans stop running.	[-55.0 ÷ 50.0] °C	R134a: 40.0 °C R449A: 20.0 °C	R134a: 40.0 °C R449A: 10.0 °C	0.0 °C		10.0 °C	0.0 °C	Pr1
	FHy	Hysteresis recovery blocking fans	[0.1 ÷ 25.5] °C	2.0 °C			2.0 °C		Pr1	
	dCF	Evaporative fan cycle delay after compressor stop. Fon and FoF parameters.	0 ÷ 60 (min)	0 min			0 min		Pr1	
	Fon	Time the fans will remain ON when the compressor is off.	0 ÷ 15 (min)	0 min			0 min		Pr1	
	FoF	Time the fans will remain OFF when the compressor is off.	0 ÷ 15 (min)	0 min			0 min		Pr1	
	Ftd	Evaporator self-diagnosis. If ΔT between evaporator and cold room is greater than Fdt for FdF minutes, alarm FnA. (0=off)	[0.0 ÷ 50.0] °C	0 °C			15 °C		Pr1	
	FdF	Maximum time where ΔT between evaporator and cold room is greater than Fdt.	0 ÷ 30 (min)	0 min			30 min		Pr1	
CONDENSER FANS	CSP	Condenser fan control setpoint. No condensation control.	[-55.0 ÷ 50.0] °C	R449A: 25 °C / R134a: 25 °C		20.0 °C		Pr2		
		Condenser fan control setpoint. Centrifugal fan condensation control.		R449A: 20 °C / R134a: 25 °C						
		Condenser fan control setpoint. Axial fan condensation control.		R449A: 20 °C / R134a: 25 °C						
	CHy	Hysteresis for condenser fan control.	[0.1 ÷ 25.5] °C	5.0 °C			10.0 °C		Pr2	
	CnP	Reference probe for condenser control.	nP - P1 - P2 -...- P6	P3			P3		Pr2	
	Cdt	Condenser self-diagnosis. Condenser temperature for fan activation.	[0.1 ÷ 25.5] °C	0.1 °C			0.1 °C		Pr1	
	CdF	Condenser self-diagnosis. Maximum time for condenser temperature to be ≥ Cdt.	0 ÷ 30 (min)	0 min			0 min		Pr1	
CdP	Reference probe for condenser control (trA=Cnd).	nP - P1 - P2 -...- P6	P3			P3		Pr2		
ANALOGUE OUTPUTS	AOt	Analogue output type 4-20mA or 0-10V (Cur= 4 to 20 mA; tEn= 0 to 10 V).	Cur - tEn	tEn			tEn		Pr2	
	trA	Analogue output function. UAL= constant value; FAN= control evaporator fans; Cnd= condenser fans control; Ind=independent.	UAL - FAN - Cnd - Ind	Cnd			Cnd		Pr2	
	Aor	Control type for the modulation of the analogue output (Ht=heat type; CL=cool type).	CL - Ht	CL			CL		Pr2	
	UAP	Reference probe for analogue output. (trA=FAN; ind).	nP - P1 - P2 -...- P6	P3			P3		Pr2	
	SdP	Set point for analogue output (trA=Cnd; ind).	[-55.0 ÷ 150.0] °C	20.0 °C			20.0 °C		Pr2	
	ASr	Offset (temp/pressure) for regulation setpoint (trA=FAN; Cnd; ind).	[-25.5 ÷ 25.5] °C	0.0 °C			0.0 °C		Pr2	
	PbA	Fan proportional band (with trA=Csd).	[0.1 ÷ 50.0] °C	25.0 °C			25.0 °C		Pr2	
	AMi	Minimum value of the analogue output for fans.	0 ÷ 100	0			40		Pr2	
	AMA	Maximum value of the analogue output for fans.	25 ÷ 100	100			100		Pr2	
	AMt	Activation time of the fans at maximum speed.	0 ÷ 60 (s)	0 s			0 s		Pr2	
	AAS	Fixed fan speed if reference probe fails.	25 ÷ 100	70			70		Pr1	
	SOA	Fixed fan speed for when trA=UAL.	25 ÷ 100	70			70		Pr2	
	AES	Fixed speed for when Energy Saving is activated (trA=FAN; Cnd).	25 ÷ 100	70			70		Pr2	
	AdF	Active fans during defrost (trA=Fan).	AMi - AMA	AMA			AMA		Pr2	
AdS	Fan speed during defrost (trA=Fan).	40 ÷ 100	100			100		Pr2		
AUXILIAR	ACH	Type of regulation for the auxiliary relay (Ht=heat type; CL=cool type).	CL - Ht	Ht			Ht		Pr2	
	Aod	Time delay for switching off the auxiliary relay.	0 ÷ 60 (min)	0 min			0 min		Pr2	
	SAA	Set point for the regulation of the auxiliary relay. (Do not modify).	[-55.0 ÷ 150.0] °C	-18.0 °C (Pr1)			5.0 °C (Pr2) PG35%= -14.0 °C (Pr2)		Pr1/ Pr2	

PARAMETER	DESCRIPTION	RANGE	SIGILUS, INTARSPLIT, INTARBOX and WATERLOOP (MDM/BDM-S)			WATERLOOP (MCC/BCC)		LIST
			High Temp.	Medium Temp.	Low Temp.	Medium Temp.	Low Temp.	
SHy	Differential for the regulation of the auxiliary relay.	[0.1 ÷ 25.5] °C	2.0 °C			2.0 °C		Pr1
	Reference probe for auxiliary relay regulation.	nP - P1 - P2 -...- P6	nP			P4		Pr2
	Blocking of auxiliary relay during defrost (Y= is blocked; N= is not blocked).	n - Y	no			no		Pr2
PUMP DOWN	PdC Pump down configuration, nu= not active; PrS= active by low pressure switch; tiM= active by time.	nu - PrS - tiM	nu	tiM		nu		Pr2
	MPt Maximum delay for compressor cut-off during pump down.	0 ÷ 255 (s)	10 s	Electric defrost: 10 s Gas defrost: 3 s		3 s		Pr1
	LPr Delay for compressor start-up once the solenoid valve opens.	0 ÷ 255 (s)	10 s			10 s		Pr1
ALARMS	A1P Selects the probe used to indicate cold room temperature alarms.	nP - P1 - P2 -...- P6	P1			P1		Pr2
	ALC Temperature alarm configuration (ALU and ALL): rE=relative to setpoint temperature; Ab=absolute temperature.	rE - Ab	rE			rE		Pr1
	ALU Alarm value for abnormally high cold room temperature.	[0.0 ÷ 50.0] °C	5.0 °C			5.0 °C		Pr1
	ALL Alarm value for abnormally low cold room temperature.	[0.0 ÷ 50.0] °C	5.0 °C			5.0 °C		Pr1
	AHy Temperature alarm reset differential.	[0.1 ÷ 25.5] °C	2.0 °C			2.0 °C		Pr1
	ALd Delay for temperature alarm signalling since detection time.	0 ÷ 255 (min)	5 min			5 min		Pr1
	dAo Time during which no temperature alarm warnings shall be displayed after the equipment is switched on.	0.0 ÷ 24.0 (h. min)	3.0 (3h 0min)		4.0 (4h 0min)	3.0 (3h 0min)		Pr1
	A2P Selects the probe used to signal the condenser temperature alarm.	nP - P1 - P2 -...- P6	P3			P4		Pr2
	A2L Value for low condenser temperature alarm.	[-55.0 °C ÷ ALU]	-55.0 °C			0.0 °C PG35%= -16.0 °C		Pr2
	H2L Condenser low temperature differential alarm (A2L).	[0.1 ÷ 25.5] °C	5.0 °C			2.0 °C		Pr2
	A2U Value for high condenser temperature alarm.	[0.0 ÷ 150.0] °C	R134a: 65 °C / R449A: 55 °C		55.0 °C	90 °C		Pr2
	H2H Differential alarm for high condenser temperature (A2U).	[0.1 ÷ 25.5] °C	3.0 °C			3.0 °C		Pr2
	A2d Time in minutes between the detection of a condenser alarm and its signalling.	0 ÷ 255 (min)	0 min			0 min		Pr2
	d2A Time after start-up during which no condenser alarms are displayed.	0.0 ÷ 24.0 (h. min)	0.0 (0h 0min)			0.0 (0h 0min)		Pr2
	bLL Compressor lockout due to low temperature alarm (A2L).	n - Y	no			no		Pr2
	CnL Condenser lockout due to low temperature alarm (A2L).	n - Y	YES			YES		Pr2
	A2C Compressor lockout due to high temperature alarm (A2L).	n - Y	no			YES		Pr2
	CnH Condenser activation if the temperature (A2P) exceeds the value indicated in A2U.	n - Y	YES			YES		Pr2
	EdA Time after a defrost during which no temperature alarms are displayed.	0 ÷ 255 (min)	30 min			30 min		Pr2
	dot Time during which no temperature alarm warnings shall be displayed after a door open alarm.	0 ÷ 255 (min)	30 min			30 min		Pr2
tbA Alarm relay/buzzer silencing when a key is pressed.	n - Y	no			no		Pr1	
OUTPUTS CONFIGURATION	oA1 Configuration of the 1st relay: CP= compressor relay 1.		CP			CP		Pr2
	oA2 Configuration of the 2nd relay: dEF= defrost 1; AUX= auxiliary relay.		dEF			AUS		Pr2
	oA3 Configuration of the 3rd relay: FAn= evaporator fan.		FAn			FAn		Pr2
	oA4 Configuration of the 4th relay: Cnd= condenser.		Cnd			Cnd		Pr2
	oA5 Configuration of the 5th relay: LiG= light; dEF= defrost 1.		LiG			dEF		Pr2
	oA6 Configuration of the 6th relay: SOL= liquid solenoid; ALr= alarm relay.		SOL			ALr		Pr2
	AOP Alarm relay polarity: CL= normally closed; OP= normally open.	OP - CL	CL			CL		Pr1
	iAU Independent auxiliary output On/Off status: n=not independent; Y=independent.	n - Y	YES			YES		Pr2
DIGITAL INPUTS	i1P Polarity of digital input no.1: CL=Close; OP=Open.	OP - CL	OP			OP		Pr2
	i1F Configuration of digital input no.1: PAL=High-pressure switch activation.		PAL			PAL		Pr2
	d1d Time interval for digital input 1 activation.	0 ÷ 255 (min)	60 min			0 min		Pr2
	i2P Polarity of digital input no.2: CL=Close; OP=Open.	OP - CL	OP			OP		Pr2
	i2F Configuration of digital input no.2: PbL= Low-pressure switch activation.		PbL			PbL		Pr2
	d2d Time interval for digital input 2 activation.	0 ÷ 255 (min)	60 min			60 min		Pr2

PARAMETER	DESCRIPTION	RANGE	SIGILUS, INTARSPLIT, INTARBOX and WATERLOOP (MDM/BDM-S)			WATERLOOP (MCC/BCC)		LIST
			High Temp.	Medium Temp.	Low Temp.	Medium Temp.	Low Temp.	
KEYBOARD	i3P	Polarity of digital input no.3: CL=Close; OP=Open.	OP - CL	OP			OP	Pr1
	i3F	Configuration digital input no.3: dor= door open.		dor			dor	Pr1
	d3d	Time interval for digital input 3 activation.	0 ÷ 255 (min)	15 min			15 min	Pr1
	nPS	Maximum number of activations of safety inputs before the control is locked.	0 ÷ 15	8			8	Pr2
	OdC	OFF status compressor (CPr), fan (Fan), both (F-C), or neither (no) when opening the cold room door.	no - FAn - CPr - F-C	F-C			F-C	Pr2
	rrd	Delay for equipment start-up after door open alarm signal.	0 ÷ 255 (min)	30 min			30 min	Pr1
	PCo	Display alarm after activation of virtual safety digital input (Common DI). (Do not modify)	n - Y	YES			YES	Pr2
KEYBOARD	AUC	AUX key configuration (7th key).		Remote control VX-760: AUS Remote control LM-660 (XL): ES			ES	Pr2
	ESC	Configuration ES key (8th key).		Remote control VX-760: ONF Remote control LM-660 (XL): AUS			AUS	Pr2
	oFC	On-Off key configuration.		Remote control VX-760: ES Remote control LM-660 (XL): ONF			ONF	Pr2
INTERNAL CLOCK	CbP	Enable internal clock.	n - Y	no			no	Pr1
	Hur	Current hour for the internal clock.	0 ÷ 23 h					Pr1
	Min	Current minutes for the internal clock.	0 ÷ 59 min					Pr1
	dAY	Current day of the week for the internal clock.						Pr1
	Hd1	First public holiday of the week, nu: do not assign any day.		nu			nu	Pr1
	Hd2	Second public holiday of the week, nu: do not assign any day.		nu			nu	Pr1
	Hd3	Third public holiday of the week, nu: do not assign any day.		nu			nu	Pr1
	ILE	Energy Saving start time.	0.0 ÷ 23.5 h	0h			0h	Pr1
	dLE	Energy Saving duration.	0.0 ÷ 24.0 h	0h			0h	Pr1
	ISE	Energy Saving start time (public holidays).	0.0 ÷ 23.5 h	0h			0h	Pr1
	dSE	Energy Saving duration (public holidays).	0.0 ÷ 24.0 h	0h			0h	Pr1
	HES	Energy Saving offset setpoint.	-30.0 ÷ 30.0					Pr1
	Ld1	Defrost 1st start time.	0.0 ÷ 23.5 h	nu			nu	Pr1
	Ld2	Defrost 2nd start time.	0.0 ÷ 23.5 h	nu			nu	Pr1
	Ld3	Defrost 3rd start time.	0.0 ÷ 23.5 h	nu			nu	Pr1
	Ld4	Defrost 4th start time.	0.0 ÷ 23.5 h	nu			nu	Pr1
	Ld5	Defrost 5th start time.	0.0 ÷ 23.5 h	nu			nu	Pr1
	Ld6	Defrost 6th start time.	0.0 ÷ 23.5 h	nu			nu	Pr1
	Sd1	Defrost start time 1st (public holiday).	0.0 ÷ 23.5 h	nu			nu	Pr1
	Sd2	Defrost start time 2nd (public holiday).	0.0 ÷ 23.5 h	nu			nu	Pr1
	Sd3	Defrost start time 3rd (public holiday).	0.0 ÷ 23.5 h	nu			nu	Pr1
	Sd4	Defrost start time 4th (public holiday).	0.0 ÷ 23.5 h	nu			nu	Pr1
Sd5	Defrost start time 5th (public holiday).	0.0 ÷ 23.5 h	nu			nu	Pr1	
Sd6	Defrost start time 6th (public holiday).	0.0 ÷ 23.5 h	nu			nu	Pr1	
E. S.	HES	Variation of the setpoint temperature in energy saving mode. (Energy Saving)	[-30.0 ÷ 30.0] °C	2.0 °C			2.0 °C	Pr1
LAN ADMINISTRATION	LMd	Defrost synchronisation.	n - Y	YES			YES	Pr2
	dEM	End of defrost synchronisation.	n - Y	YES			YES	Pr2
	LSP	SET POINT synchronisation.	n - Y	YES			YES	Pr2
	LdS	Display synchronisation.	n - Y	no			no	Pr2
	LSd	Remote probe display.	n - Y	no			no	Pr2
	LOF	ON/OFF synchronisation.	n - Y	YES			YES	Pr2
	LLi	Lights synchronisation.	n - Y	YES			YES	Pr2
	LAU	Auxiliary output synchronisation.	n - Y	no			no	Pr2
	LES	Night-time operation synchronisation (Energy Saving).	n - Y	YES			YES	Pr2
	StM	LAN cold call which activates cooling in all connected equipment.	n - Y	no			no	Pr2
PROBE CONFIGURATION	P1C	P1 probe configuration.	nP - Ptc - ntC - PtM	ntC			ntC	Pr2
	ot	P1 probe calibration.	[-12.0 ÷ 12.0] °C	0.0 °C			0.0 °C	Pr2
	P2C	P2 probe configuration.	nP - Ptc - ntC - PtM	ntC			ntC	Pr2
	oE	P2 probe calibration.	[-12.0 ÷ 12.0] °C	0.0 °C			0.0 °C	Pr2
	P3C	P3 probe configuration.	nP - Ptc - ntC - PtM	ntC			ntC	Pr2

PARAMETER	DESCRIPTION	RANGE	SIGILUS, INTARSPLIT, INTARBOX and WATERLOOP (MDM/BDM-S)			WATERLOOP (MCC/BCC)		LIST	
			High Temp.	Medium Temp.	Low Temp.	Medium Temp.	Low Temp.		
o3	P3 probe calibration.	[-12.0 ÷ 12.0] °C		0.0 °C		0.0 °C		Pr2	
	P4C	P4 probe configuration.	nP - Ptc - ntC - PtM		ntC		ntC		Pr2
	o4	P4 probe calibration.	[-12.0 ÷ 12.0] °C		0.0 °C		0.0 °C		Pr2
	P5C	P5 probe configuration.	nP - Ptc - ntC - PtM		nP		nP		Pr2
	o5	P5 probe calibration.	[-12.0 ÷ 12.0] °C		0.0 °C		0.0 °C		Pr2
	P6C	P6 probe configuration.	nP - Ptc - ntC - PtM		nP		nP		Pr2
o6	P6 probe calibration.	[-12.0 ÷ 12.0] °C		0.0 °C		0.0 °C		Pr2	
OTHER	MAP	Enabling the safety parameter map.						Pr1	
	Adr	Serial Address: Identifies the serial address of the instrument connected within a ModBUS serial network.	1 ÷ 247		1		1		Pr1
	rEL	Software version.	(read only)						Pr2
	Ptb	Table of parameters.	0 ÷ 65535		1		1		Pr2
	Pr2	Access to the protected parameter list.	(read only)						Pr1
	SEZ	LAN mode of operation.	(read only)		LOC		LOC		
	HM	Access to the Clock menu.							Pr1
	An	Percentage reading of the analogue output.							Pr1
	dP1	P1 probe reading.	°C						Pr1
	dP2	P2 probe reading.	°C						Pr1
	dP3	P3 probe reading.	°C						Pr1
	dP4	P4 probe reading.	°C						Pr1
	dP5	P5 probe reading.	°C						Pr1
	dP6	P6 probe reading.	°C						Pr1
	LSn	Displays the number of devices on the LAN.	1 ÷ 8 (read only)						Pr1
	LAn	Identifies the serial address of the equipment on the local LAN.	1 ÷ 247 (read only)						Pr1
	in1	1st digital input status display.	°C		OFF		OFF		Pr1
	in2	2nd digital input status display.	°C		OFF		OFF		Pr1
	in3	3rd digital input status display.	°C		OFF		OFF		Pr1
	ou1	1st digital output status display.	°C		OP		OP		Pr1
	ou2	2nd digital output status display.	°C		OP		OP		Pr1
	ou3	3rd digital output status display.	°C		OP		OP		Pr1
	ou4	4th digital output status display.	°C		OP		OP		Pr1
	ou5	5th digital output status display.	°C		OP		OP		Pr1
	ou6	6th digital output status display.	°C		OP		OP		Pr1
	L ^o t	Minimum temperature reading detected.	°C						Pr1
	H ^o t	Maximum temperature reading detected.	°C						Pr1

18. Alarm messages

MESSAGE	CAUSE	EQUIPMENT ACTION (outputs status)	REARME
Pon	Active keyboard.	Outputs unchanged.	
PoF	Keyboard locked. To unlock it, press and hold  +  for 3 seconds at the same time.	Outputs unchanged.	
rst	Alarm reset. Appears when an alarm is active and a key on the keypad is pressed.	Resetting the alarm relay.	
rtc	Internal clock not set. Set the parameters "Hur", "Min" and "dAY" as indicated in section 7.	Outputs unchanged.	
rff	Faulty internal clock.	Outputs unchanged.	
EE	EEPROM faulty.	Exits blocked.	
nod	A device connected to the LAN is disconnected or the polarity of the LAN is not respected.	Outputs unchanged.	
AS1	There is an active alarm on device no. 1 of the LAN network.	Depending on the type of active alarm.	
AS2	There is an active alarm on device no. 2 of the LAN network.	Depending on the type of active alarm.	
AS3	There is an active alarm on device no. 3 of the LAN network.	Depending on the type of active alarm.	
AS4	There is an active alarm on device no. 4 of the LAN network.	Depending on the type of active alarm.	
AS5	There is an active alarm on device no. 5 of the LAN network.	Depending on the type of active alarm.	
AS6	There is an active alarm on device no. 6 of the LAN network.	Depending on the type of active alarm.	
AS7	There is an active alarm on device no. 7 of the LAN network.	Depending on the type of active alarm.	
AS8	There is an active alarm on device no. 8 of the LAN network.	Depending on the type of active alarm.	

MESSAGE	CAUSE	EQUIPMENT ACTION (outputs status)	REARME
LA2	Low condenser temperature alarm (set in parameter A2L).	If enabled in bLL outputs blocked.	Automatic. When the temperature exceeds A2L+H2L.
HA2	High condenser temperature alarm (set in parameter A2U).	If enabled in CnL and A2C, fans active at 100% and compressors blocked.	Automatic. When the temperature is lower than A2U-H2H.
HP	Number of activations of the high-pressure switch exceeded (nPS) in the period (d1d).	Blocked exits	Manual.
LP	Number of activations of the low-pressure switch exceeded (nPS) in the period (d2d), or low pressure switch open for a time longer than d2d.	Blocked exits	Manual.
PCo	Open safety line. Virtual digital input (DI common).	Exits blocked.	Automatic.
PCb	Number of activations (nPS) of PCo exceeded.	Exits blocked.	Manual.
LPA	Low pressure switch alarm. Pump-down active. Alarm due to non-activation of the low-pressure switch after starting refrigerant after timing LPr time.	Solenoid open and evaporator fan active.	Automatic. When resetting the pressure switch.
AMP	Low pressure switch alarm has not fallen within Mpt time when pressure pump-down is performed (PdC=PrS).		Automatic. When a new demand for cooling occurs
dPA	Alarm due to activation of the low-pressure switch during a hot gas defrost.	The compressor stops and the solenoid opens.	Automatic. When resetting the pressure switch.
dA	Door open alarm. (If digital input 3 is configured as door switch) VARIOUS USES. DIGITAL INPUT 3.	Compressor and fans resume regulation according to "rrd" and "odc" parameters.	Automatic.
CPA	The condenser temperature/pressure does not increase Cdt degrees in CdF seconds.	Outputs unchanged.	Automatic. When the compressor stops.
HA	High cold room temperature alarm.	Outputs unchanged.	Automatic. When the cold room temperature is lower than ALU-AHy or lower than Set+ALU-AHy (according to ALC).
LA	Low cold room temperature alarm.	Outputs unchanged	Automatic. When the cold room temperature is higher than ALL+AHy or higher than Set+ALU-AHy (according to ALC).
P1	Probe 1 failure alarm	Outputs unchanged	
P2	Probe 2 failure alarm	Outputs unchanged	
P3	Probe 3 failure alarm	Outputs unchanged	
P4	Probe 4 failure alarm	Outputs unchanged	
P5	Probe 5 failure alarm	Outputs unchanged	
P6	Probe 6 failure alarm	Outputs unchanged	

19. Intelligent self-diagnostic functions

The XM670K electronic control includes an intelligent self-diagnostic control that warns the user that an anomaly has occurred or is occurring in the operation of the equipment that could lead to a serious fault. The control warns by an on-screen code and an audible signal from the remote control. These warnings do not stop the equipment but are important enough to require an installer to supervise its operation to prevent further problems.

Intelligent self-diagnostic warnings:

dFA: Self-diagnosis of defrosting

If after starting a defrost the defrost probe temperature (**Pb2**) does not detect a temperature rise of 5 K (**ddt**) within 5 minutes (**ddf**), the message "**dFA**" is generated on the display. This could be a symptom that the defrosting resistors are not heating up correctly.

dFL: Self-diagnosis of defrosting

If 5 (**AdC**) consecutive defrosts are completed by time instead of temperature, the message "**dFL**" is generated on the display. This could be a symptom that the evaporator is being blocked with ice. The warning disappears when a defrost by temperature is completed.

FnA: Self-diagnosis of evaporator fans

If the temperature of the cold room probe (**Pb1**) is 15 K (**Ftd**) higher than the temperature of the defrost probe (**Pb2**) for at least 30 min (**FdF**), the message "**FnA**" is generated on the display. This could be a symptom that the evaporator fans are not working properly. The warning disappears when the temperature differential is less than 15 K (**Ftd**).

To override the self-diagnostics the parameters shall have the following settings:

dFA -> ddF=0

dFL -> AdC=0

FnA -> Ftd=0



Head office and factory:

Pol. Ind. Los Santos, Bulevar de Los Santos 34, Apdo. 410

14900 - Lucena - Córdoba (Spain)

Tlf. +34 957 50 92 93

www.intarcon.com