

**True**®

MANUFACTURING CO., INC.

The Industries Most Complete Refrigeration Source



# TEMPERATURE CONTROL ADJUSTMENTS

# CABINET SEQUENCE OF OPERATIONS



*truve*®  
MANUFACTURING CO., INC.

# TABLE OF CONTENTS

**NOMENCLATURE** \_\_\_\_\_ **6**

**CABINET HOLDING TEMPERATURES** \_\_\_\_\_ **7**

**OPERATION** \_\_\_\_\_ **8**

Types of Temperature Controls / Startup \_\_\_\_\_ 8

Light Switches \_\_\_\_\_ 11

Temperature Control Locations \_\_\_\_\_ 12

**MECHANICAL TEMPERATURE CONTROLS** \_\_\_\_\_ **28**

Mechanical Temperature Control General Sequence of Operation \_\_\_\_\_ 29

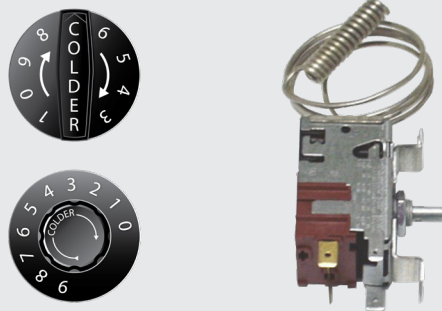

How to Diagnose \_\_\_\_\_ 31

Checking the Cut In and Cut Out of the Temperature Control \_\_\_\_\_ 32

Conditions That Could Cause A Temperature Control Misdiagnosis \_\_\_\_\_ 32

When & How Make an Adjustment to a Mechanical Temperature Control \_\_\_\_\_ 33

Danfoss Temperature Control Adjustment \_\_\_\_\_ 34

**DEFROST TIMERS** \_\_\_\_\_ **36**

Paragon Defrost Timer \_\_\_\_\_ 37

Grasslin Defrost Timer \_\_\_\_\_ 38

Mallory Defrost Timer \_\_\_\_\_ 45



Paragon

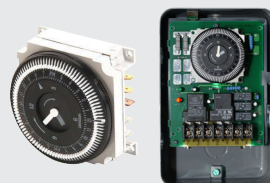

Grasslin



Mallory

# TABLE OF CONTENTS

## ELECTRONIC TEMPERATURE CONTROLS \_\_\_\_\_ 47

Dixell Electronic Temperature Control \_\_\_\_\_ 49

Using the Dixell Electronic Control \_\_\_\_\_ 50

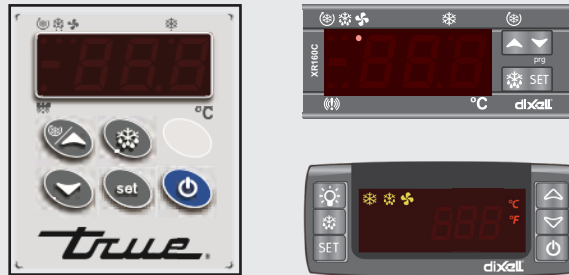

LAE Electronic Temperature Control \_\_\_\_\_ 59

Using the LAE Electronic Control \_\_\_\_\_ 62



Danfoss Electronic Temperature Control \_\_\_\_\_ 74

Using the Danfoss Electronic Control \_\_\_\_\_ 77

Troubleshooting (Danfoss Electronic Control) \_\_\_\_\_ 83



Sollatek Electronic Temperature Control \_\_\_\_\_ 87

Using the Sollatek Electronic Control \_\_\_\_\_ 88



HST - Health Safety Timer \_\_\_\_\_ 93

Using the Health Safety Timer \_\_\_\_\_ 96

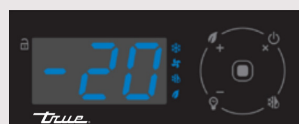

## NOMENCLATURE

<b>AC</b>	Air Curtain
<b>ADA</b>	Americans With Disabilities Act Compliant
<b>AL</b>	Angled Lid
<b>C</b>	Convenience Store Cooler
<b>CD</b>	Cold Deli
<b>CT</b>	Club Top
<b>D</b>	Drawer
<b>DG</b>	Dry Goods
<b>DS</b>	Dual Sided
<b>DT</b>	Dual Temperature
<b>F</b>	Freezer
<b>FC</b>	Floral Case
<b>FG</b>	Glass Door Freezer
<b>FGD01</b>	Framed Glass Door, Version 01
<b>FL</b>	Flat Lid
<b>FLM</b>	Full Length Merchandiser
<b>FR</b>	Food Rated
<b>FZ</b>	Zero Degree Freezer
<b>G</b>	Glass Door
<b>GAL</b>	Galvanized Top
<b>GC</b>	Glass/Plate Chiller
<b>GDIM</b>	Glass Door Ice Merchandiser
<b>GDM<sup>®</sup></b>	Glass Door Merchandiser
<b>GEM</b>	Glass End Merchandiser
<b>GS</b>	Glass Sided
<b>G4SM</b>	Four-Sided Glass
<b>HST</b>	Health Safety Timer
<b>L</b>	Low-Height
<b>LD</b>	LED Lighting
<b>LP</b>	Low Profile
<b>MB/MC</b>	Mega Top
<b>NT</b>	No Tank (Ice Merchandisers)
<b>PT</b>	Pass-Through
<b>RF</b>	Radius Front
<b>RGS</b>	Rotating Glass Shelf
<b>RI</b>	Roll-In
<b>RL</b>	Rear Load
<b>RT</b>	Roll-Through
<b>S</b>	Stainless Steel

<b>SD</b>	Slide Door
<b>SI</b>	Sign
<b>SL</b>	Slim Line
<b>SPEC1</b>	Undercounter/Worktop Spec Series 1
<b>SS</b>	Stainless Steel Interior
<b>SSL</b>	Super Slim Line
<b>ST</b>	Split Top
<b>STR/STA/STG</b>	Spec Series <sup>®</sup> Models
<b>T</b>	TRUE <sup>®</sup>
<b>TAC<sup>®</sup></b>	Vertical Air Curtain
<b>TBB<sup>®</sup></b>	Back Bar
<b>TBR</b>	True Bar Refrigerator
<b>TCGG</b>	Curved Glass Gravity Coil Deli Case
<b>TD</b>	Deep Well Horizontal Bottle Cooler
<b>TDB</b>	Back Bar/Direct Draw
<b>TDBD</b>	Double Duty Deli
<b>TDC</b>	Dipping Cabinet
<b>TDD</b>	Direct Draw
<b>TDM</b>	Display Merchandiser
<b>TDR</b>	True Draft Refrigerator
<b>TFM</b>	Frozen Merchandiser
<b>TFP</b>	Food Prep Table
<b>THAC</b>	Horizontal Air Curtain
<b>TMC</b>	Milk Cooler
<b>TOAM</b>	Open Air Merchandiser
<b>TPP<sup>®</sup></b>	Pizza Prep Table
<b>TRCB</b>	Chef Base
<b>TS</b>	Stainless Steel Exterior & Interior Reach-In
<b>TSCI</b>	Scientific Series
<b>TSD</b>	Slide Door
<b>TSID</b>	Single Duty Deli
<b>TSL01</b>	TRUE Standard Look, Version 01
<b>TSSU<sup>®</sup></b>	Sandwich/Salad Unit
<b>T-SERIES<sup>®</sup></b>	Upright Reach-In
<b>TUC<sup>®</sup></b>	Undercounter
<b>TVM</b>	Visual Merchandiser
<b>TWT</b>	Work Top
<b>W</b>	Wine Merchandiser

# TRUE PRODUCT HOLDING TEMPERATURES

## TECHNICAL INFORMATION

- **FLM (Full Length Merchandiser) Freezer**  
Holds -10°F (-23.3°C)
- **FLM (Full Length Merchandiser) Refrigerator**  
Holds 33°F to 38°F (0.5°C to 3.3°C)
- **GDIM (Glass Door Ice Merchandiser)**  
Holds 20°F to 25°F (-6.7°C to -3.9°C)
- **GDM (Glass Door Merchandiser) Freezer**  
Holds -10°F (-23.3°C)
- **GDM (Glass Door Merchandiser) Refrigerator**  
Holds 33°F to 38°F (0.5°C to 3.3°C)
- **STR, STA, STG (Spec Series) Freezer**  
Holds -10°F (-23.3°C)
- **STR, STA, STG (Spec Series) Heated**  
Holds 140°F to 180°F (60°C to 82.2°C)
- **STR, STA, STG (Spec Series) Refrigerator**  
Holds 33°F to 38°F (0.5°C to 3.3°C)
- **T-Series Freezer**  
Holds -10°F (-23.3°C)
- **T-Series Refrigerator**  
Holds 33°F to 38°F (0.5°C to 3.3°C)
- **TAC (Vertical Air Curtain) Refrigerator**  
Holds 33°F to 38°F (0.5°C to 3.3°C)
- **TBB (Back Bar) Refrigerator**  
Holds 33°F to 38°F (0.5°C to 3.3°C)
- **TBR (Back Bar) Refrigerator**  
Holds 33°F to 38°F (0.5°C to 3.3°C)
- **TCGG (Curved Glass Deli Case) Refrigerator**  
Holds 38°F to 40°F (3.3°C to 4.5°C)
- **TCGR (Curved Glass Display Case) Refrigerated Bakery**  
Holds 38°F to 40°F (3.3°C to 4.5°C)
- **TCGR-CD (Curved Glass Display Case) Cold Deli**  
Holds 36°F to 38°F (0.5°C to 3.3°C)
- **TD (Horizontal Bottle Coolers) Refrigerator**  
Holds 33°F to 38°F (0.5°C to 3.3°C)
- **TD-LT (Horizontal Bottle Coolers / Low Temp Models)**  
Holds 20°F (-6.7°C)
- **TDB (Back Bar / Direct Draw Beer Dispenser) Refrigerator**  
Holds 33°F to 38°F (0.5°C to 3.3°C)
- **TDBD (Double Duty Deli Cases) Refrigerator**  
Holds 38°F to 40°F (3.3°C to 4.5°C)
- **TDC (Dipping Cabinet) Freezer**  
Holds -10°F to 8°F (-23.3°C to -13.3°C)
- **TDD (Direct Draw Beer Dispensers) Refrigerator**  
Holds 33°F to 38°F (0.5°C to 3.3°C)
- **TDM (True Display Merchandiser) Refrigerator**  
Holds 33°F to 41°F (0.5°C to 5°C),  
Optionally 42°F to 65°F (5.5°C to 18.3°C)
- **TDR (Direct Draw Beer Dispensers) Refrigerator**  
Holds 33°F to 38°F (0.5°C to 3.3°C)
- **TFM (Horizontal Freezers)**  
Holds -10°F (-23.3°C)
- **TFP (Food Prep) Refrigerator**  
Holds 33°F to 41°F (0.5°C to 5°C)
- **T-GC (Glass & Plate Chillers / Frosters)**  
Holds 0°F and below
- **TH Series (Heated Cabinet)**  
Holds 80°F to 200°F (26.6°C to 93.3°C)
- **THAC (Horizontal Air Curtain) Refrigerator**  
Holds 35°F to 40°F (1.6°C to 4.4°C)
- **THDC (Horizontal Dipping Cabinet) Freezer**  
Holds -10°F to 8°F (-23.3°C to -13.3°C)
- **TMC (Milk Coolers) Refrigerator**  
Holds 33°F to 38°F (0.5°C to 3.3°C)
- **TOAM (Open Air Merchandiser) Refrigerator**  
Holds 33°F to 40°F (0.5°C to 4.4°C)
- **TPP (Pizza Prep Table) Refrigerator**  
Holds 33°F to 41°F (0.5°C to 5°C)
- **TR, TA, TG (Spec Series) Freezer**  
Holds -10°F (-23.3°C)
- **TR, TA, TG (Spec Series) Refrigerator**  
Holds 33°F to 38°F (0.5°C to 3.3°C)
- **TR, TA, TG (Spec Series) Heated Cabinets**  
Holds 80°F to 180°F (26.6°C to 82.2°C)
- **TRCB (Chef Bases) Refrigerator**  
Holds 33°F to 38°F (0.5°C to 3.3°C)
- **TS (Stainless Steel) Freezer**  
Holds -10°F (-23.3°C)
- **TS (Stainless Steel) Refrigerator**  
Holds 33°F to 38°F (0.5°C to 3.3°C)
- **TSCI (Scientific Series) Refrigerator**  
Holds 35.6°F to 46.4°F (2°C to 8°C)
- **TSD (Slide Door) Refrigerator**  
Holds 33°F to 38°F (0.5°C to 3.3°C)
- **TSID (Single Duty Deli Cases) Refrigerator**  
Holds 38°F to 40°F (3.3°C to 4.5°C)
- **TSSU (Sandwich / Salad) Refrigerator**  
Holds 33°F to 41°F (0.5°C to 5°C)
- **TUC (Undercounter) Freezer**  
Holds -10°F (-23.3°C)
- **TUC (Undercounter) Refrigerator**  
Holds 33°F to 38°F (0.5°C to 3.3°C)
- **TVM (True Visual Merchandiser) Refrigerator**  
Holds 33°F to 38°F (0.5°C to 3.3°C)
- **TWT (Worktop) Freezer**  
Holds -10°F (-23.3°C)
- **TWT (Worktop) Refrigerator**  
Holds 33°F to 38°F (0.5°C to 3.3°C)

## OPERATION

### TYPES OF TEMPERATURE CONTROLS

The cabinet's General Sequence of Operation is determined by the temperature control.

What is a temperature control or thermostat?

A temperature control or thermostat is a device that is interposed in a cooling system by which temperature is automatically maintained between certain levels.

#### STARTUP

- A. Temperature controls are factory-set to give refrigerators an approximate temperature of 35°F (1.6°C) and freezers an approximate temperature of -10°F (-23.3°C). Allow unit to function several hours, completely cooling cabinet before changing the control setting.
- B. Excessive tampering with the control could lead to service difficulties. Should it ever become necessary to replace temperature control, be sure it is ordered from your TRUE dealer or recommended service agent.

#### GENERAL SEQUENCE OF OPERATION FOR HEATED CABINETS

When the cabinet is plugged in:

- Interior lights will illuminate on Glass Door models (see light switch location).
- An Electronic Control with Digital Display will illuminate (if installed).
- There may be a short delay before the heater(s) start. This delay may be determined by time or by temperature. This delay may be time or temperature determined.

The temperature control/thermostat is sensing an air temperature, not a product temperature. An analog thermometer, a digital thermometer, or an electronic control display may reflect the heating cycle swings of up and down temperatures, not a product temperature.

The most accurate method to determine a cabinet's operation is to verify the product temperature.

## OPERATION CONT.

### GENERAL SEQUENCE OF OPERATION FOR REFRIGERATOR AND FREEZER CABINETS

#### When the cabinet is plugged in:

- Interior lights will illuminate on Glass Door models (see light switch location, page 6).
- An Electronic Control with Digital Display will illuminate (if installed).
- There may be a short delay before the compressor and/or evaporator fan(s) start. This delay may be determined by time or by temperature. This delay may also be the result of an initial defrost event that will be a minimum of 6 minutes.
- The temperature control/thermostat may cycle the compressor and evaporator fan(s) on and off together.  
**EXCEPTION:** models TSID, TDBD, TCGG, and TMW do not have evaporator fan(s).
- The temperature control/thermostat is sensing either an evaporator coil temperature or air temperature, not a product temperature.

An analog thermometer, a digital thermometer, or an electronic control display may reflect the refrigeration cycle swings of up and down temperatures, not a product temperature. The most accurate method to determine a cabinet's operation is to verify the product temperature.

Every cabinet will require a defrost event to ensure the evaporator coil remains clear of frost and ice buildup. Defrost is initiated by a defrost timer or by the temperature control. A refrigerator with a mechanical temperature control will defrost during every compressor off-cycle. A freezer with a mechanical temperature control will defrost by time initiation as determined by a defrost timer.

**EXCEPTION:** models TFM, TDC, THDC and TMW will require a manual defrost.

The frequency of this manual defrost will depend on the cabinet's usage, and ambient conditions. An Electronic Control will defrost by either a time initiation or on demand as determined by the electronic control. An Electronic Control with a Digital Display (if installed) will show "def" during defrost.

**NOTE:** the display may have a short delay before showing a temperature after defrost has expired and may show "def" during a refrigeration cycle.

Models with an analog or digital thermometer may show higher than normal temperatures during defrost.

A refrigerator will use the evaporator fans to clear the coil during defrost.

**EXCEPTION:** models TSID, TDBD, and TCGG do not have an evaporator fan(s).

A freezer will use electric heaters to clear the coil during defrost.

**NOTE:** the evaporator coil heater and drain tube heater are only energized during defrost.

Defrost is terminated when a specific evaporator coil temperature is reached or by a time duration.

# MECHANICAL TEMPERATURE CONTROLS

MECHANICAL CONTROLS CYCLE THE COMPRESSOR BY SENSING EITHER AIR TEMPERATURE OR EVAPORATOR COIL TEMPERATURE.

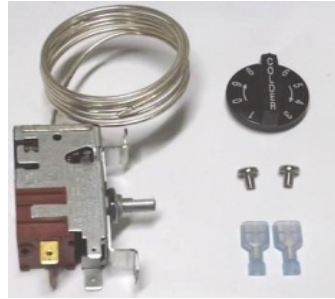

Refrigerator = Evaporator Coil

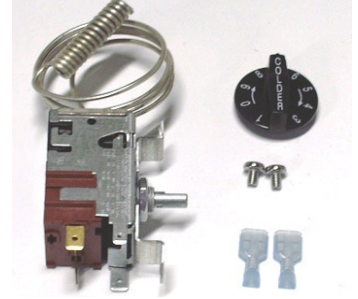

Freezer = Air

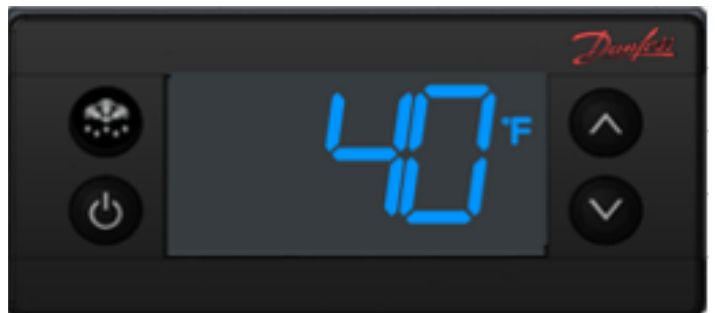

# ELECTRONIC TEMPERATURE CONTROLS

ELECTRONIC CONTROLS CYCLE THE COMPRESSOR BY SENSING AIR TEMPERATURE.



# LIGHT SWITCH LOCATION

Cabinets with glass doors, or with an open-air design may have a switch to manually turn the lights on and off. Solid-door cabinets with interior lights may not have a light switch, since the lights are typically activated when the solid door is opened.

A light switch  will be available where the light symbol  denotes its approximate location.

If a light switch is not available, the lights may be activated by the LAE electronic control



## TURNING THE LIGHTS ON AND OFF USING THE LIGHT SWITCH (IF AVAILABLE)

Depress the switch as shown. 

## TURNING THE LIGHTS ON AND OFF USING THE LAE ELECTRONIC CONTROL



**Note:** The control may need to be unlocked. Press and momentarily hold the Manual Activation Button until the lights turn on or off. Release the button.

To find the LAE electronic control and available light switch, please see the next section pertaining to "Temperature Control Locations".

# TEMPERATURE CONTROL LOCATION

Note: Control version and location may vary upon model of cabinet. Light switch availability and location may vary upon model of cabinet.

MODEL(S): FLM

Light Switch on Glass Door Models

Inside top ceiling.



Electronic Temperature Control with Display

Behind the front bottom grill.

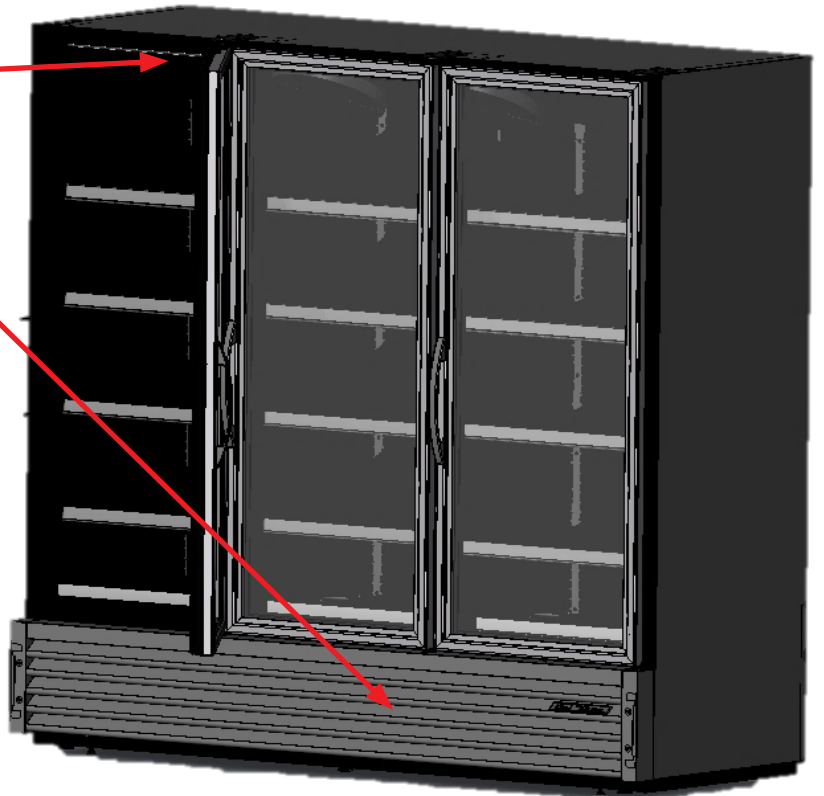

MODEL(S): GDIM

Mechanical Temperature Control

Inside top ceiling.



Light Switch on Glass Door Models

Inside top ceiling.



Electronic Temperature Control with Digital Display

Behind the front bottom louvered grill.

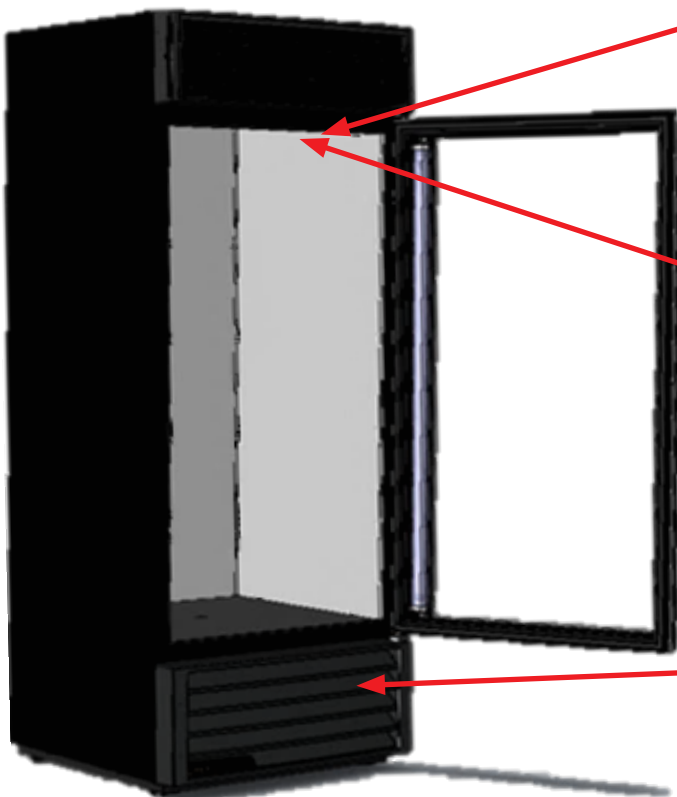

# TEMPERATURE CONTROL LOCATION

Note: Control version and location may vary upon model of cabinet. Light switch availability and location may vary upon model of cabinet.

MODEL(S): GDM

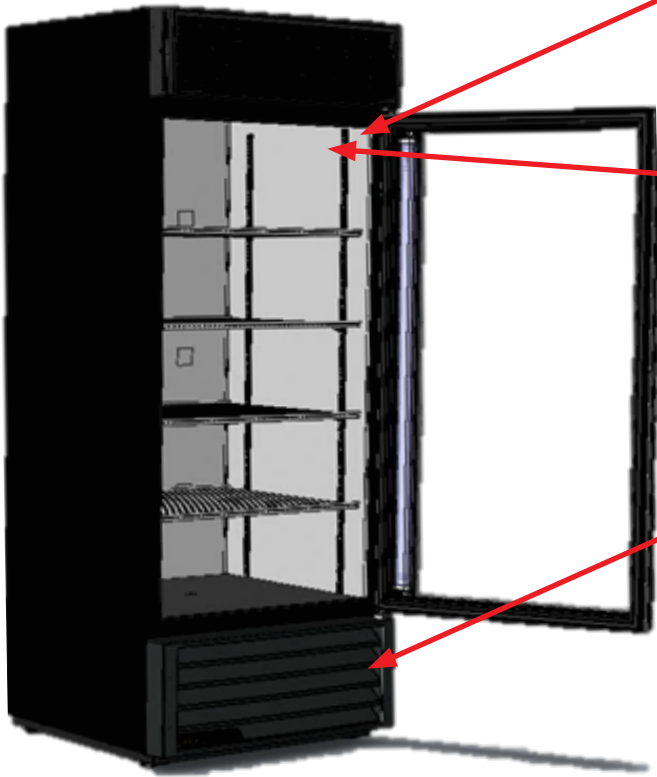

**Light Switch on Glass Door Models**

Inside top ceiling.



**Mechanical Temperature Control or Electronic Temperature Control without Digital Display**

Inside top ceiling or back wall.

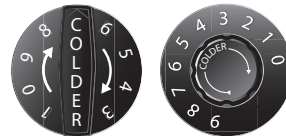

**Electronic Temperature Control with Digital Display**

Behind or mounted to the front bottom louvered grill.

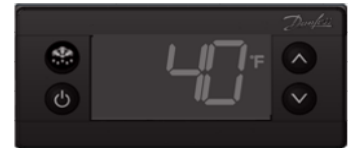

MODEL(S): STM

**Electronic Temperature Control with Digital Display**

On the front of top panel.

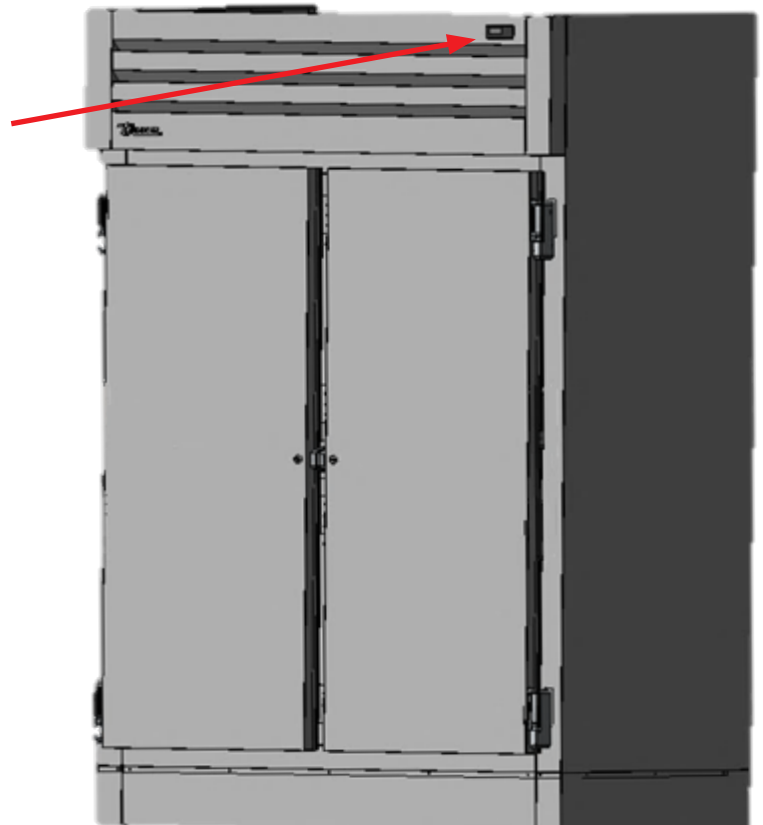

# TEMPERATURE CONTROL LOCATION

Note: Control version and location may vary upon model of cabinet. Light switch availability and location may vary upon model of cabinet.

MODEL(S): STR, STA, STG HEATED

Electronic Temperature Control with Digital Display  
On the front of top panel.

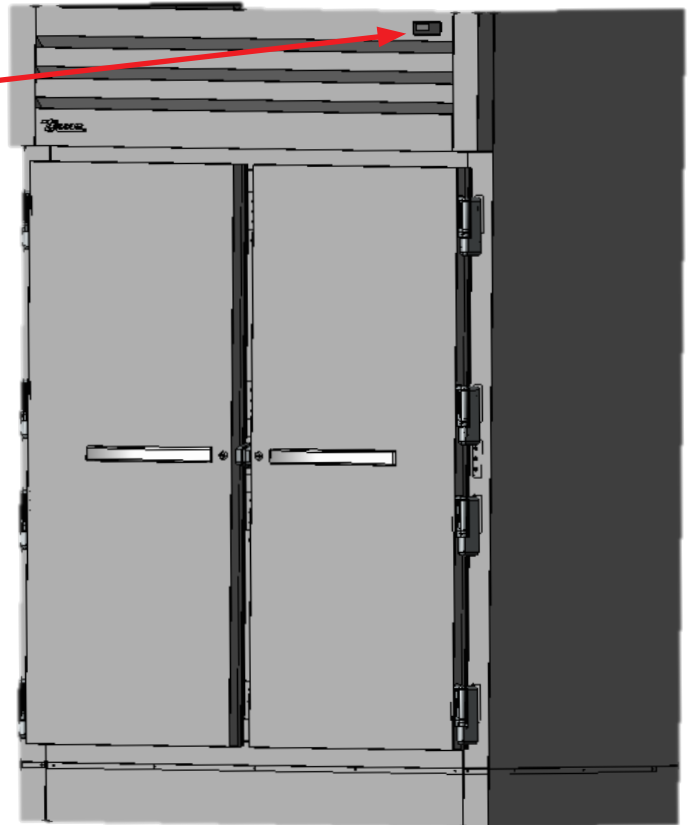

MODEL(S): STR, STA, STG REACH-IN AND REACH-THRU

Electronic Temperature Control with Digital Display  
On the front of top panel.

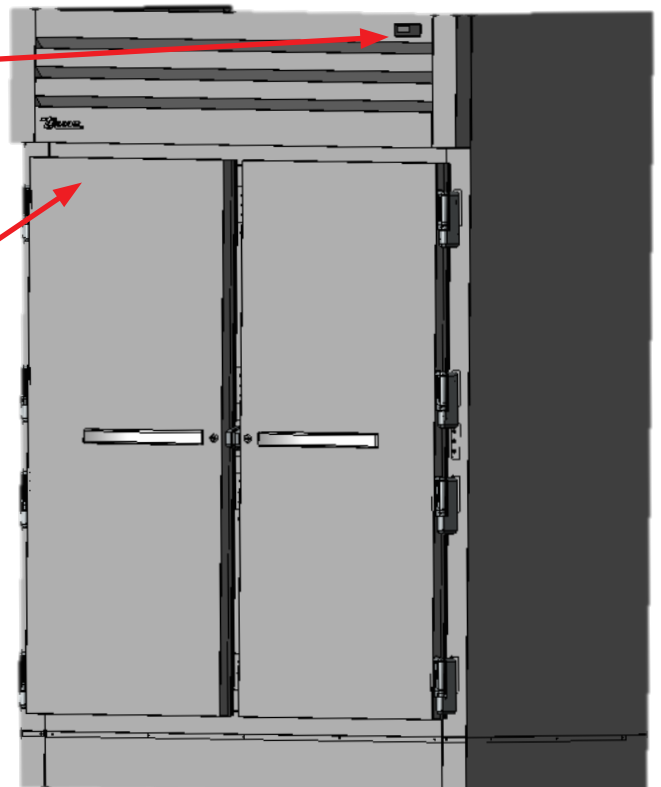

Light Switch  
Inside top ceiling.



# TEMPERATURE CONTROL LOCATION

Note: Control version and location may vary upon model of cabinet. Light switch availability and location may vary upon model of cabinet.

MODEL(S): STR, STA, STG ROLL-IN AND ROLL-THRU

Electronic Temperature Control with Digital Display  
On the front of top panel.

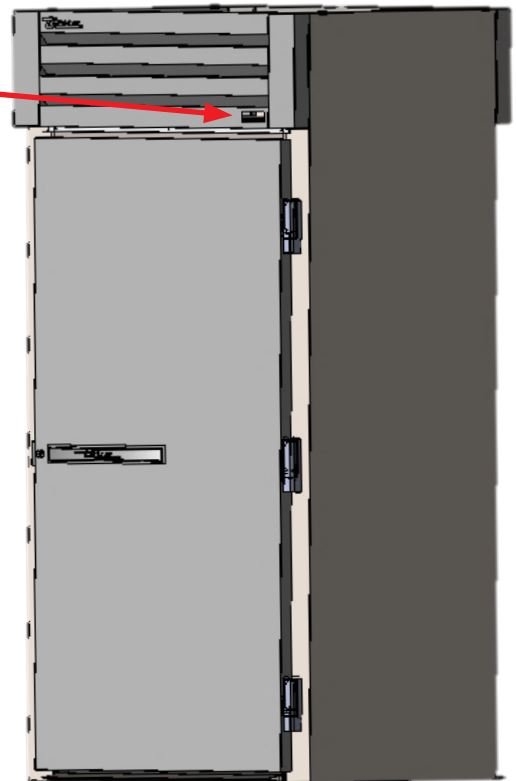

MODEL(S): T-23DT

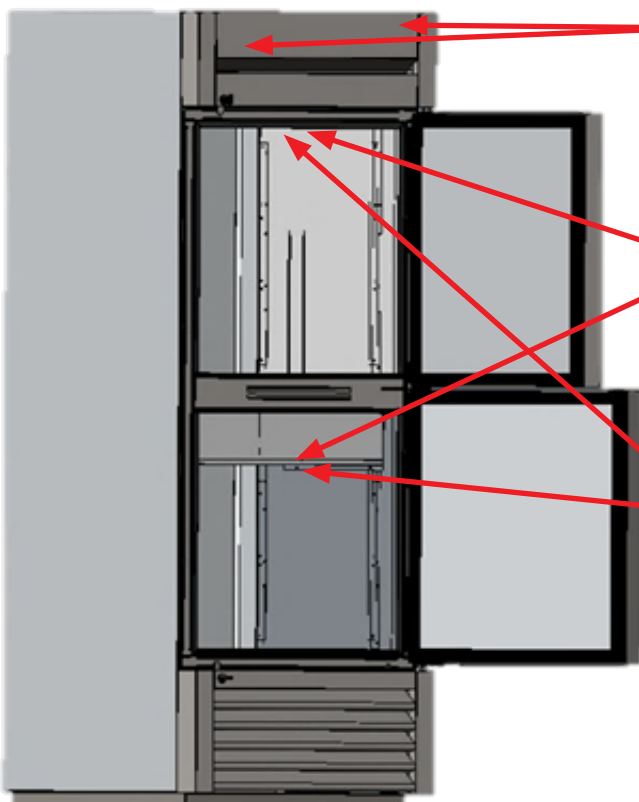

Electronic Temperature Control with Digital Display  
On the front of the top panel.



Mechanical Temperature Control  
Inside top ceiling.



Light Switch on Glass Door Models  
Inside top ceiling.



# TEMPERATURE CONTROL LOCATION

Note: Control version and location may vary upon model of cabinet. Light switch availability and location may vary upon model of cabinet.

## MODEL(S): T-SERIES

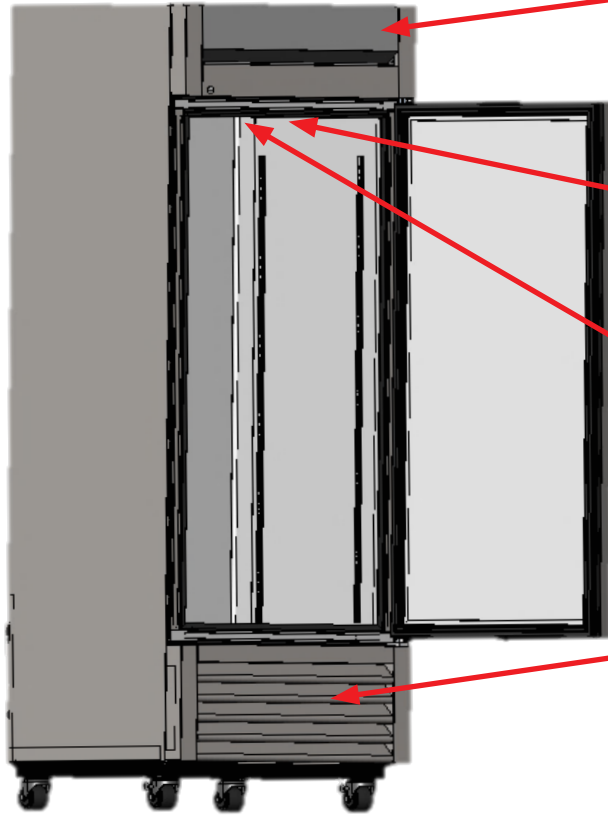

**Electronic Temperature Control with Digital Display**  
On the front of top panel.



**Light Switch on Glass Door Models**  
Inside top ceiling.



**Mechanical Temperature Control or Electronic Temperature Control without Digital Display**  
Inside top ceiling.



**Electronic Temperature Control with Digital Display**  
Behind or mounted to the front bottom louvered grill.



## MODEL(S): TAC

**Light Switch on Glass Door Models**  
Behind the top airflow honeycomb.



**Mechanical Temperature Control**  
Inside back wall, lower left.



**Electronic Temperature Control with Digital Display**  
Behind or mounted to the front bottom louvered grill.

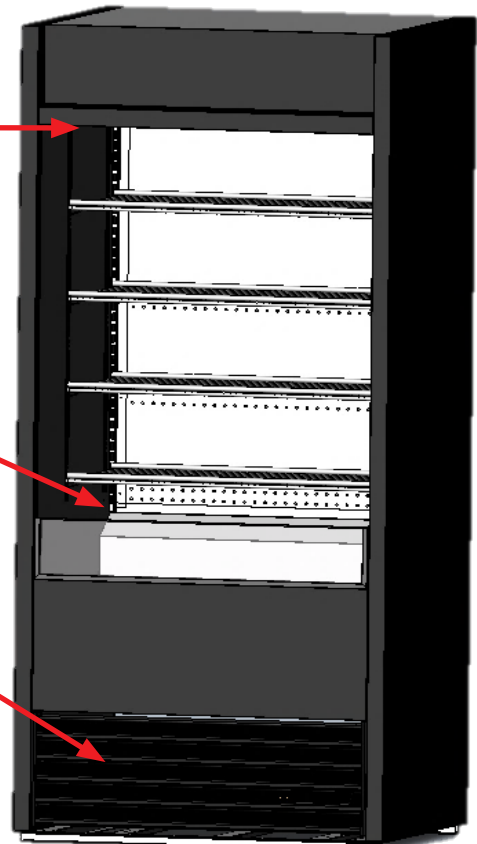

# TEMPERATURE CONTROL LOCATION

Note: Control version and location may vary upon model of cabinet. Light switch availability and location may vary upon model of cabinet.

MODEL(S): TBR, TDR

Light Switch on Glass Door Models

Inside top ceiling.



Electronic Temperature Control

On front of grill.



MODEL(S): TCGG

Light Switch on Glass Door Models

Inside top left ceiling.



Mechanical Temperature Control

Inside top left ceiling.



Electronic Temperature Control

Behind the Rear Louvered Grill.

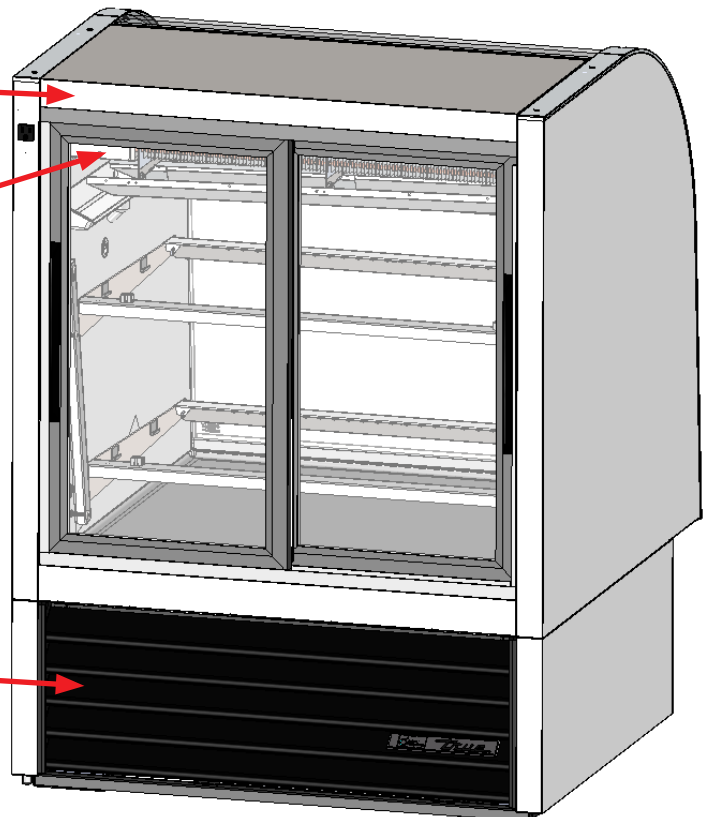

## TEMPERATURE CONTROL LOCATION

*Note: Control version and location may vary upon model of cabinet. Light switch availability and location may vary upon model of cabinet.*

**MODEL(S): TCGR, TCGD, TCGDZ**

### Mechanical Temperature Control

Alongside rear bottom grill.



Model TCGD will not have a control.

### Light Switch on Glass Door Models

Alongside rear bottom grill.

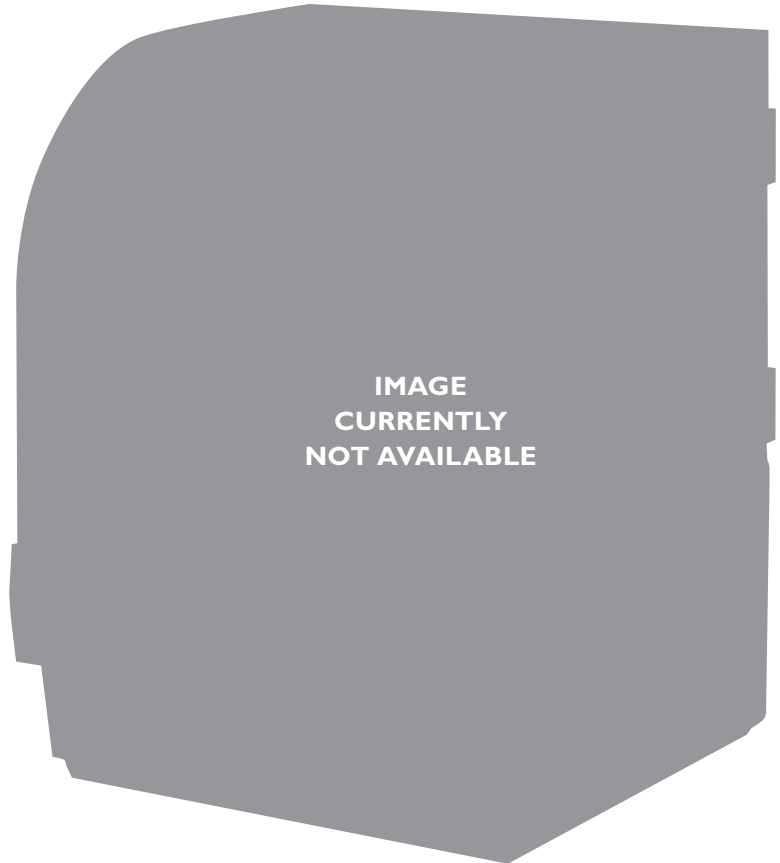

**MODEL(S): TCM**

### Mechanical Temperature Control

Behind rear bottom grill.



### Light Switch on Glass Door Models

Above evaporator housing.

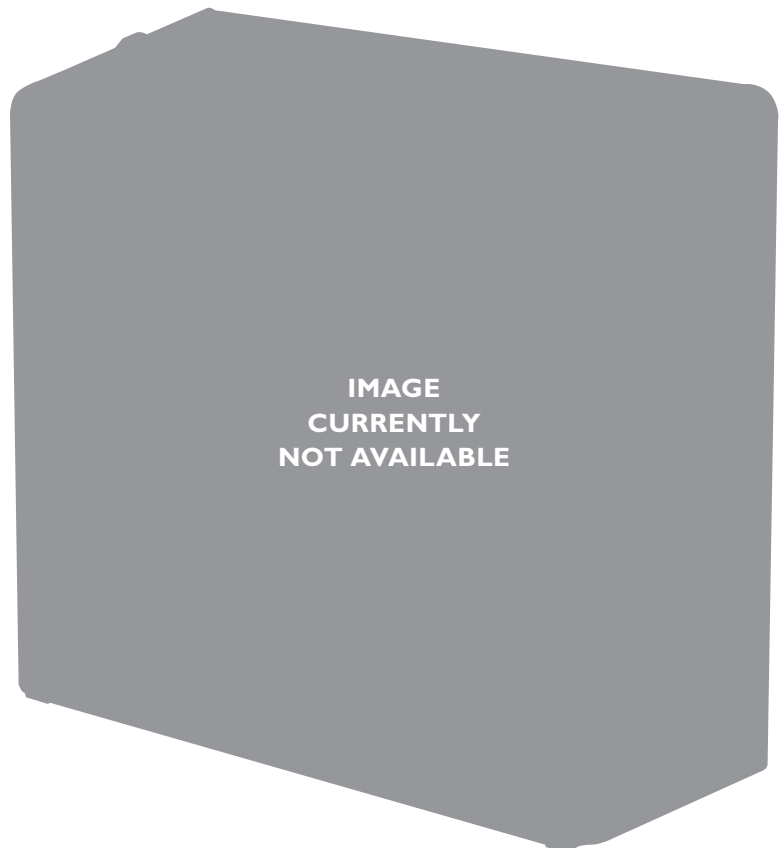

# TEMPERATURE CONTROL LOCATION

Note: Control version and location may vary upon model of cabinet. Light switch availability and location may vary upon model of cabinet.

MODEL(S): TDB, TBB, TDD, TD, T-GC

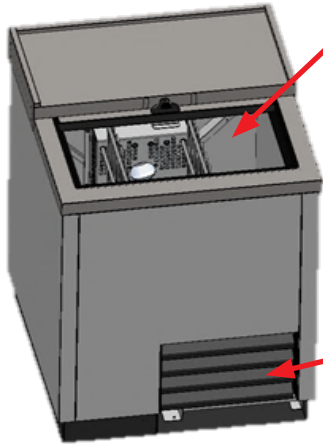

**Mechanical Temperature Control or Electronic Temperature Control Without Digital Display**  
Inside back corner.

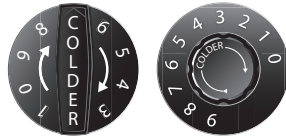

**Electronic Temperature Control without Digital Display**  
Behind front grill.



**Mechanical Temperature Control or Electronic Temperature Control without Digital Display**  
Inside right wall or back wall.

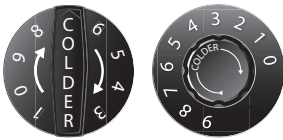

**Light Switch on Glass Door Models**  
Inside left wall or top ceiling.

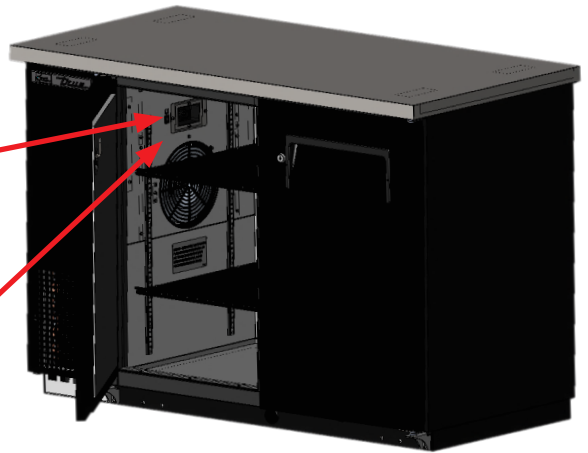

MODEL(S): TDBD, TSID

**Mechanical Temperature Control**  
Inside top left ceiling.

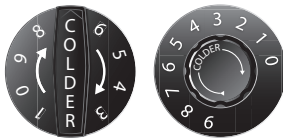

**Light Switch on Glass Door Models**  
Inside top ceiling – TSID.  
Outside back countertop – TDBD.

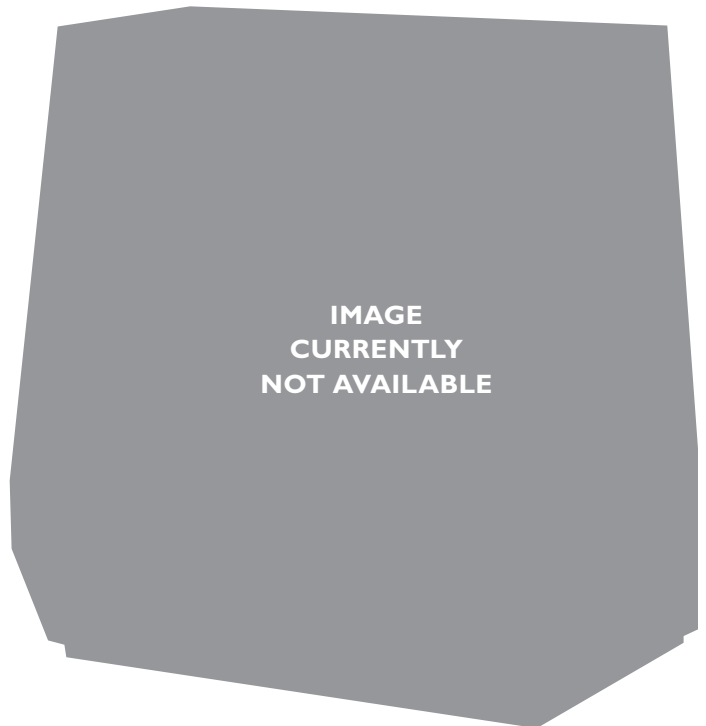

# TEMPERATURE CONTROL LOCATION

Note: Control version and location may vary upon model of cabinet. Light switch availability and location may vary upon model of cabinet.

MODEL(S): TDC, THDC

Light Switch on Glass Door Models

On top of canopy.



Mechanical Temperature Control

Alongside the back louvered grill.

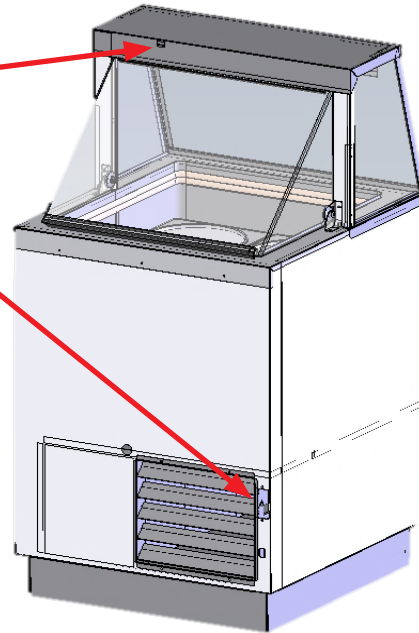

Model TDC will not have a control knob.

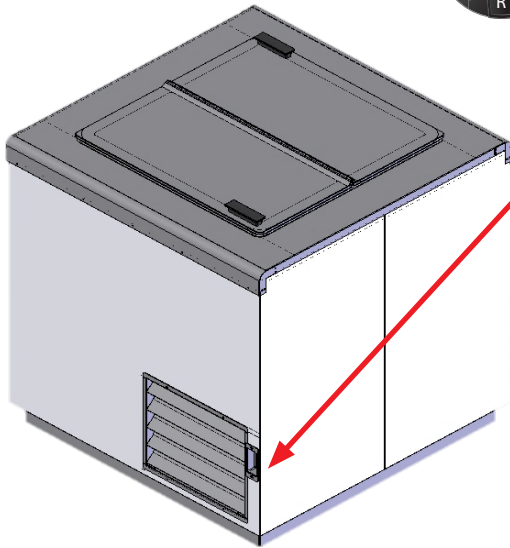

MODEL(S): TDM, TGM

Electronic Temperature Control with Digital Display

Behind clear cover.

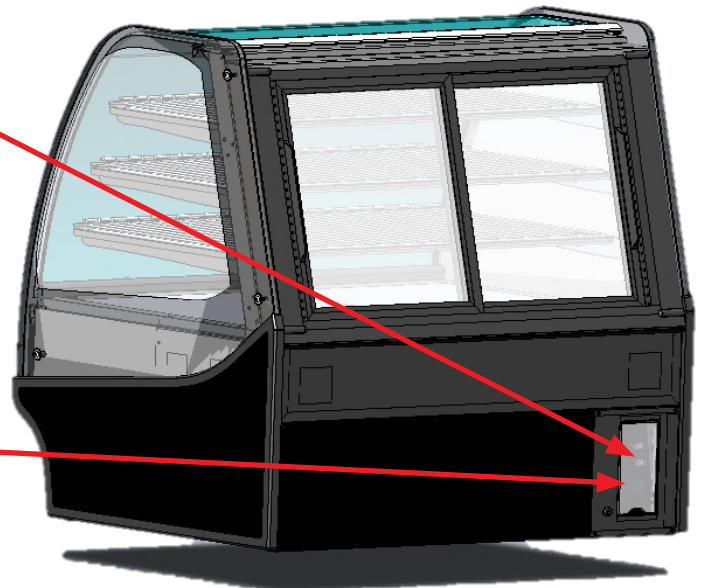

Light Switch on Glass Door Models

Behind clear cover.



# TEMPERATURE CONTROL LOCATION

Note: Control version and location may vary upon model of cabinet. Light switch availability and location may vary upon model of cabinet.

MODEL(S): TFM

Mechanical Temperature Control

Behind side bottom grill.

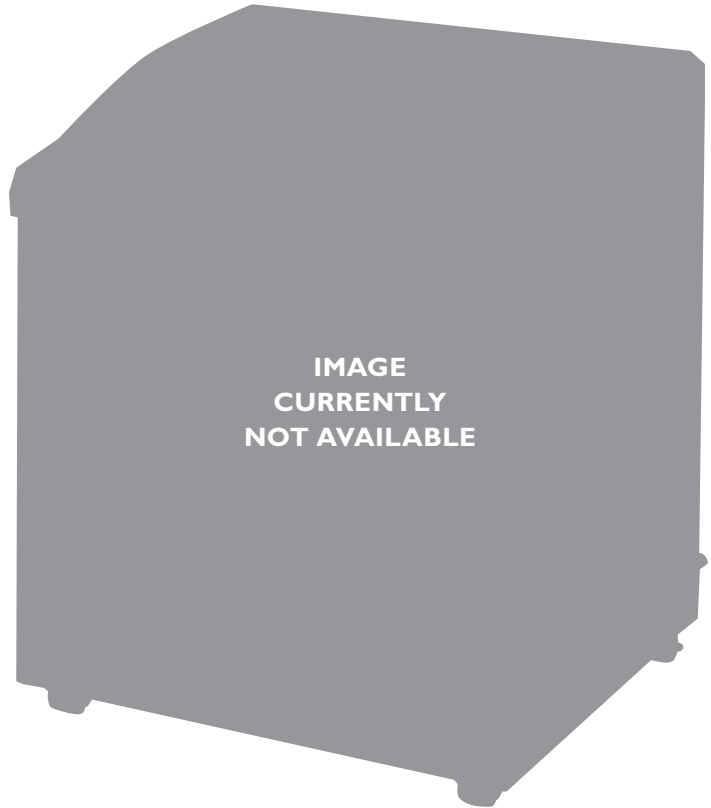

MODEL(S): TGU

Mechanical Temperature Control or Electronic Temperature Control without Digital Display  
Inside right wall.

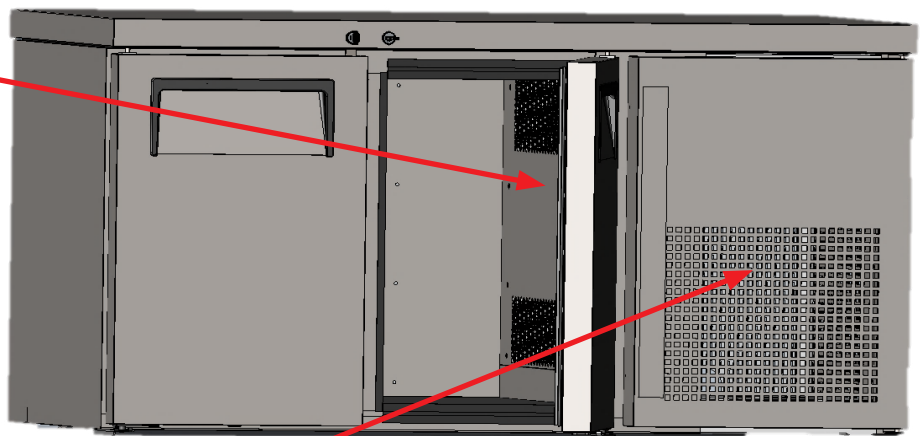

Electronic Temperature Control with Digital Display  
On front side panel.



# TEMPERATURE CONTROL LOCATION

Note: Control version and location may vary upon model of cabinet. Light switch availability and location may vary upon model of cabinet.

## MODEL(S): TH-SERIES

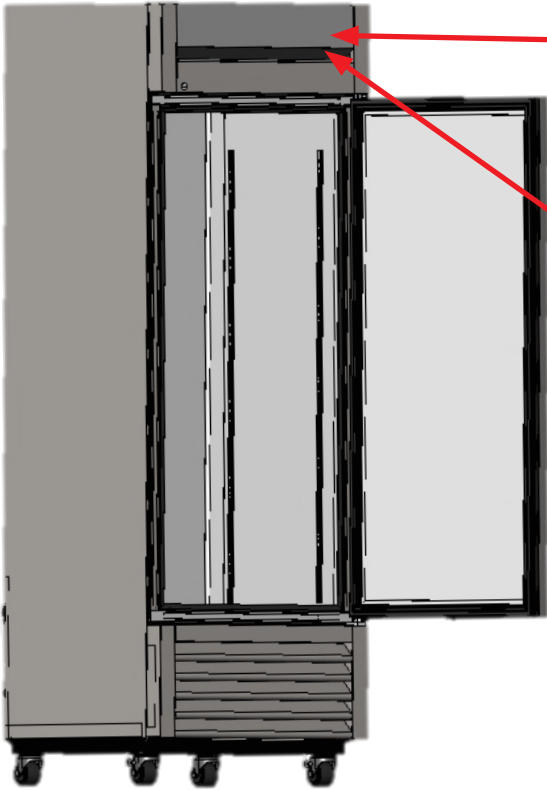

**Mechanical Temperature Control**  
On the front of the top panel.



**Light Switch on Glass Door Models**  
On the front of the top panel.



## MODEL(S): THAC

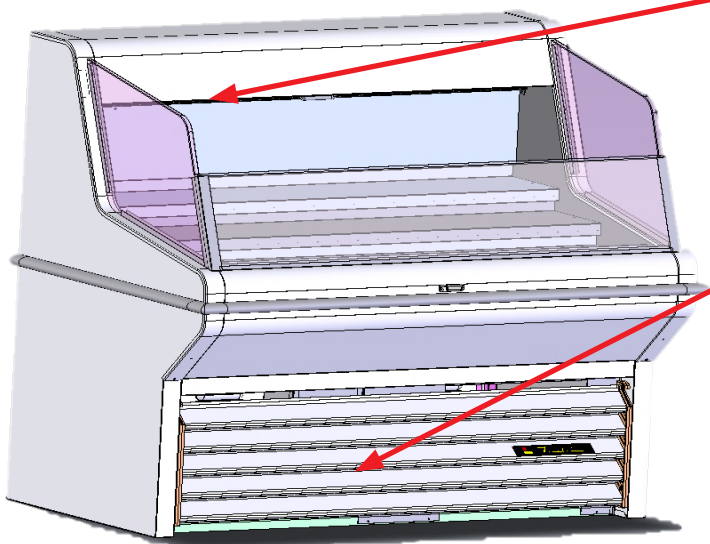

**Light Switch on Glass Door Models**  
Behind the top airflow honeycomb.



**Electronic Temperature Control with Digital Display**  
Behind the front bottom louvered grill.



# TEMPERATURE CONTROL LOCATION

Note: Control version and location may vary upon model of cabinet. Light switch availability and location may vary upon model of cabinet.

## MODEL(S): TMC

### Electronic Temperature Control with Digital Display

On the front of the top panel.



### Mechanical Temperature Control or Electronic Temperature Control without Digital Display

Inside top ceiling.

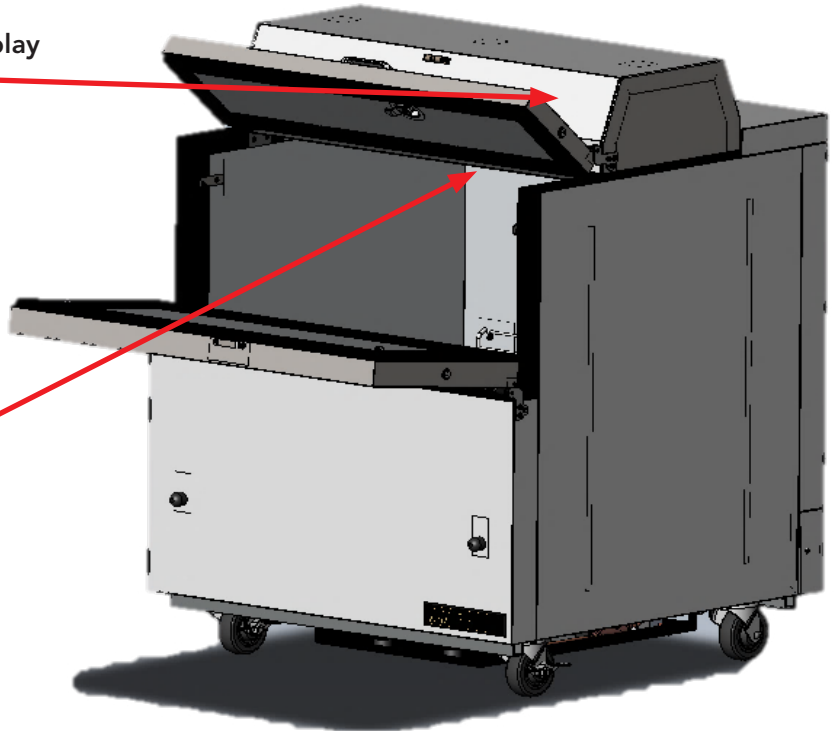
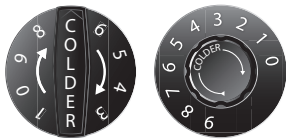

## MODEL(S): TMW

### Mechanical Temperature Control

Inside front right corner.



### Electronic Temperature Control with Digital Display

On the front panel.

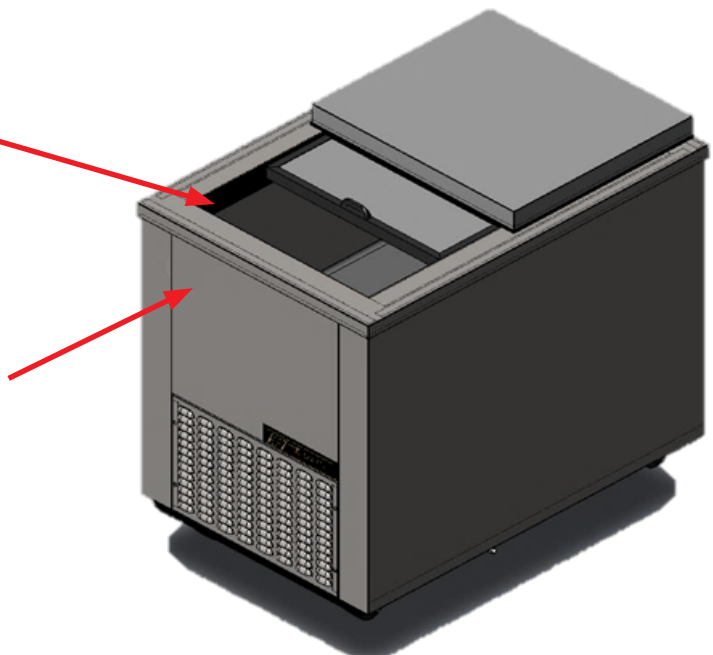

# TEMPERATURE CONTROL LOCATION

Note: Control version and location may vary upon model of cabinet. Light switch availability and location may vary upon model of cabinet.

MODEL(S): TOAM

**Light Switch on Glass Door Models**  
In front of the top air flow honeycomb.

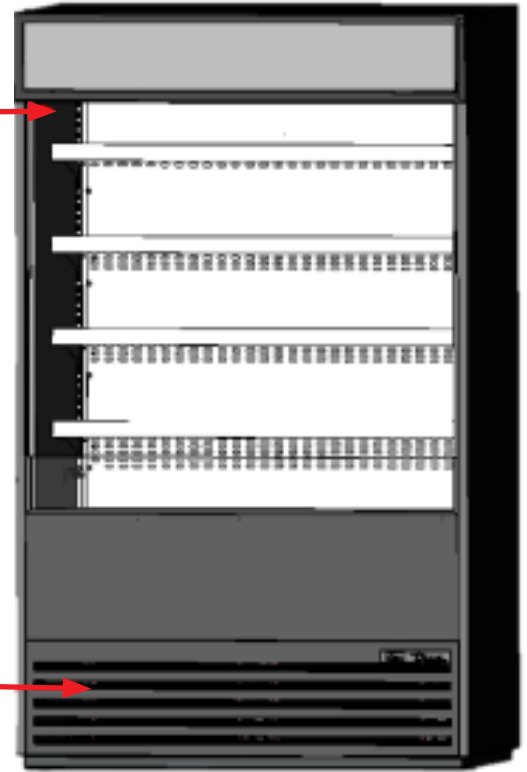

**Electronic Temperature Control**  
Behind the front grill OR through the front grill.



MODEL(S): TPP, TUC, TWT (DEEP UNDERCOUNTER OR WORKTOP MODELS)

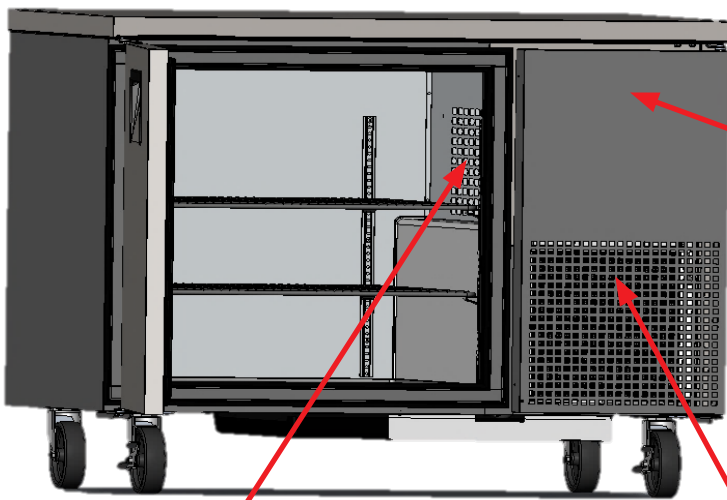

**Electronic Temperature Control with Digital Display**  
On the front of the grill.



**Mechanical Temperature Control or Electronic Temperature Control without Digital Display**  
Inside right wall.



**Electronic Temperature Control without Display**  
Behind the front grill.



# TEMPERATURE CONTROL LOCATION

Note: Control version and location may vary upon model of cabinet. Light switch availability and location may vary upon model of cabinet.

MODEL(S): TR, TA, TG REACH-IN AND REACH-THRU

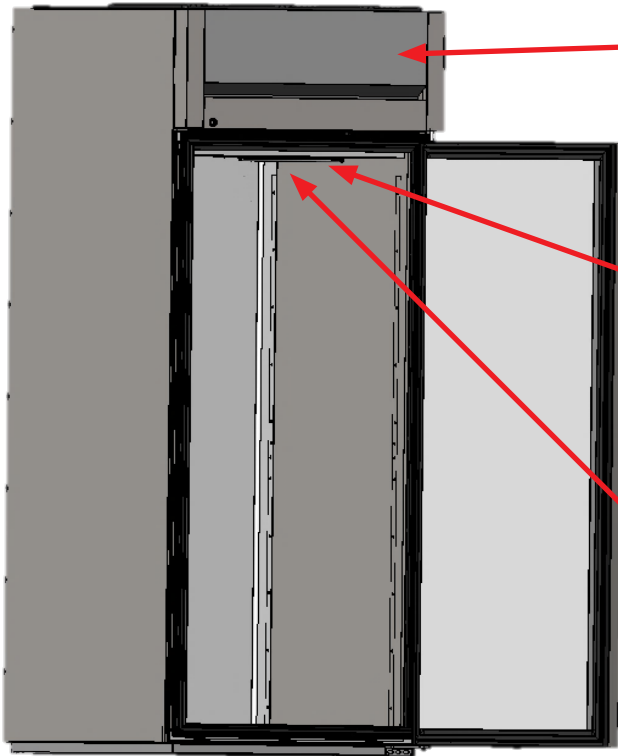

**Electronic Temperature Control with Digital Display**  
On the front of top panel.



**Mechanical Temperature Control or Electronic Temperature Control without Digital Display**  
Inside top ceiling.



**Light Switch on Glass Door Models**  
Inside top ceiling.



MODEL(S): TRCB

**Electronic Temperature Control with Digital Display**  
On the front of the grill.

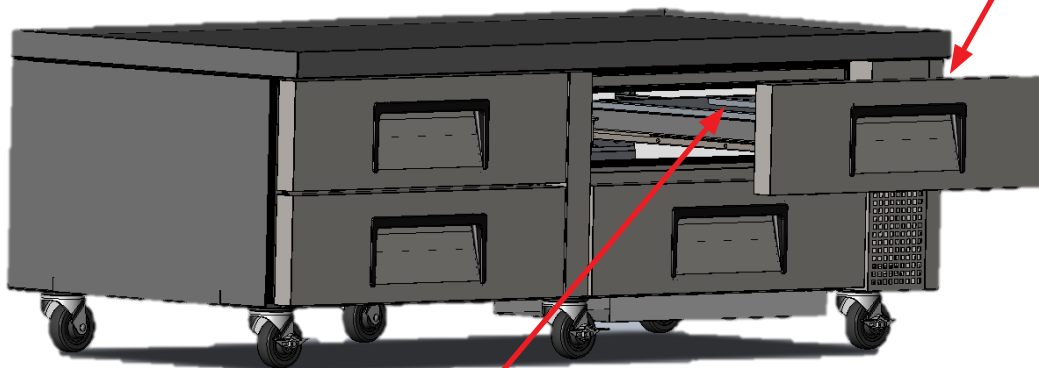

**Mechanical Temperature Control**  
Inside top ceiling or right wall.



# TEMPERATURE CONTROL LOCATION

Note: Control version and location may vary upon model of cabinet. Light switch availability and location may vary upon model of cabinet.

MODEL(S): TSSU, TFP, TUC, TWT (DOES NOT INCLUDE DEEP UNDERCOUNTER OR WORKTOP MODELS)

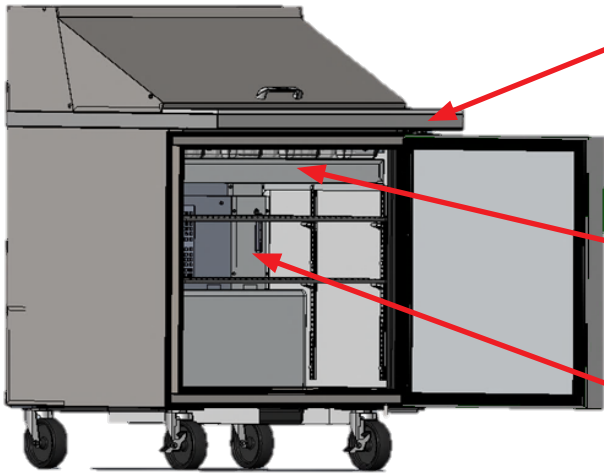

Electronic Temperature Control with Digital Display  
On the front of countertop.



Light Switch on Glass Door Models  
Top horizontal door opening.



Mechanical Temperature Control or Electronic Temperature Control without Digital Display  
Inside back corner.

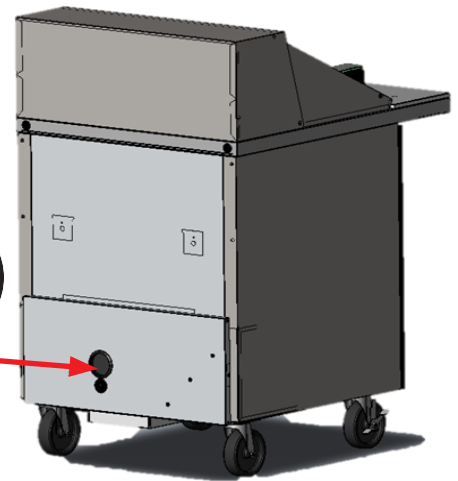

Electronic Temperature Control without Display  
Behind cap on back panel



MODEL(S): TVM

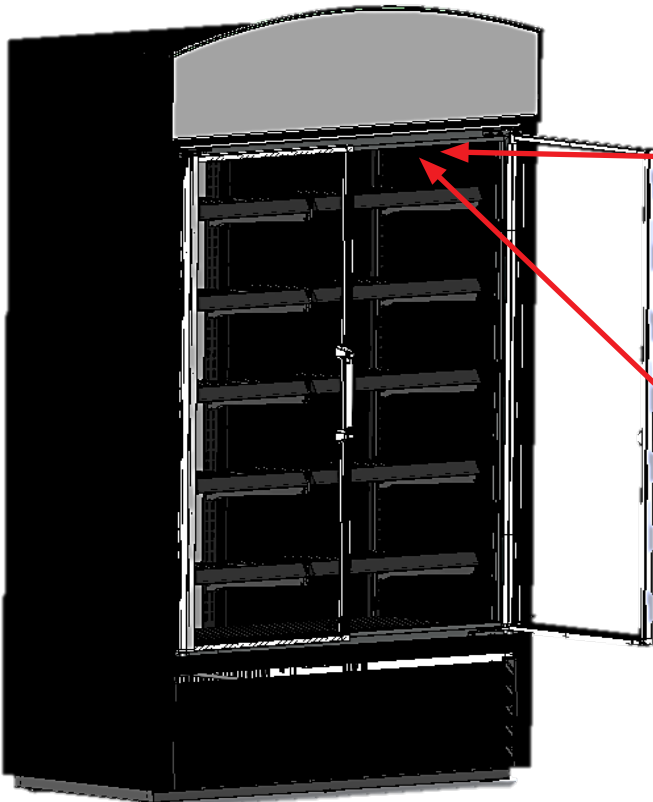

Light Switch on Glass Door Models  
Inside top ceiling.



Electronic Temperature Control without Display  
Inside top ceiling.





# MECHANICAL TEMPERATURE CONTROLS

MECHANICAL TEMPERATURE CONTROL GENERAL SEQUENCE OF OPERATION _____	29
HOW TO DIAGNOSE _____	31
CHECKING THE CUT IN AND CUT OUT OF THE TEMPERATURE CONTROL _____	32
CONDITIONS THAT COULD CAUSE A TEMPERATURE CONTROL MISDIAGNOSIS _____	32
WHEN TO MAKE AN ADJUSTMENT TO A MECHANICAL TEMPERATURE CONTROL _____	33
HOW TO ADJUST A MECHANICAL TEMPERATURE CONTROL _____	33

## MECHANICAL TEMPERATURE CONTROLS

### COIL SENSING

An evaporator coil sensing temperature control ensures that the evaporator coil will remain clear of frost and ice by not allowing the compressor to restart until the coil temperature is above the freezing temperature. This is considered an off cycle defrost.

**Note:** Some Deli Cabinets with a gravity coil system will use a regular defrost cycle without heaters to assist in clearing the coil.

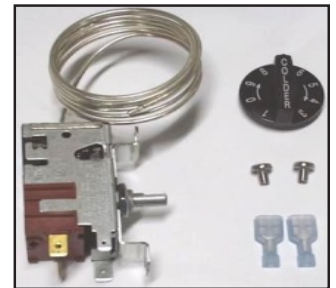

### AIR SENSING

An air sensing temperature control used in a freezer application will require a defrost cycle with heaters to ensure that the evaporator coil is kept clear of frost and ice.

**Note:** Air sensing control used for wine/chocolate do not utilize a defrost cycle as coil temperatures are above freezing.

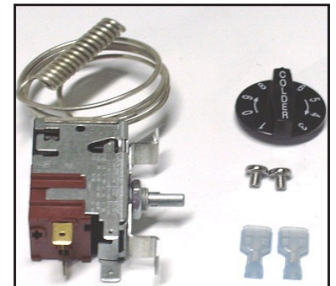

# MECHANICAL TEMPERATURE CONTROLS

White Wine: 45-50°F (8.2-10°C)  
 Red Wine / Chocolate: 50-55°F (10-12.8°C)

## GDM / T-Series Coolers

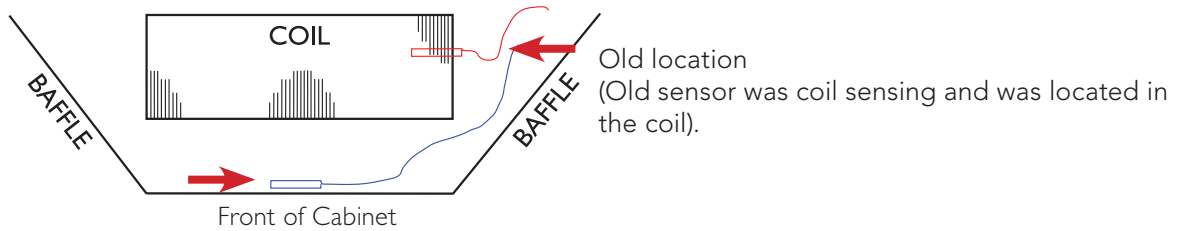

Temperature Control Pig Tail Install Here  
 (New sensor is air sensing and mounted in front of the coil).

## TBB Units

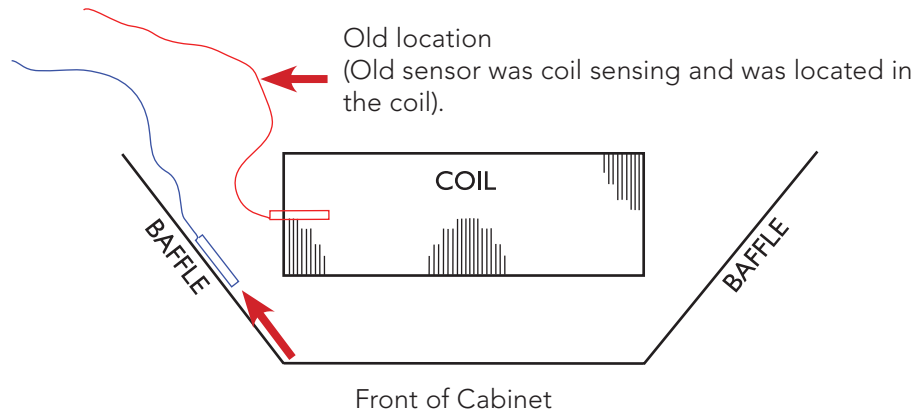

Mount as close to the evaporator housing edge as possible. Temperature Control Pig Tail Install Here  
 (New sensor is air sensing and mounted in front of the coil).

# MECHANICAL TEMPERATURE CONTROLS

## HOW TO DIAGNOSE

**STEP 1** - Control must operate within its pre-calibrated range of temperatures.

**STEP 2** - *Cut-in* is the ON temperature.

**STEP 3** - *Cut-out* is the OFF temperature.

**NOTE:** All temps are at mid-point setting #5. All temps advised have a +/- 2 degree variance.

Information is provided to verify cut-in/cut-out range for diagnostic purposes only. True recommends replacing OEM control with the same part number.



**TIP:** Some cabinets with a 1/2 horsepower compressor will use a temperature control relay that may need to be diagnosed.

TRUE P/N	TRUE P/N (KIT)	MFG P/N	APPLICATION	CUT-IN °F (°C)	CUT-OUT °F (°C)
800303		9531N376		35.0 (1.7)	14.5 (-9.7)
800304		9530N1490		-8.5 (-22.5)	-14.5 (-25.8)
800306		9531N251		40.0 (4.4)	19.0 (-7.2)
800312		9530N1284		-8.5 (-22.5)	-14.5 (-25.8)
800313		9531N335		36.5 (2.5)	16.0 (-8.9)
800320		9530N1185		32.5 (0.3)	26.5 (-3.1)
800325		9530N1318	RED WINE, CHOCOLATE	62.0 (16.7)	55.0 (12.8)
800335		9530N1376		38.0 (3.3)	20.0 (-6.7)
800340		9530N1155		26.1 (-3.3)	10.9 (-11.7)
800345	988271	077B1264		-2.6 (-19.4)	-15.5 (-26.6)
800357		9530266		-3.0 (-19.4)	-8.0 (-22.2)
800358		077B1214		-8.5 (-22.7)	-14.4 (-26.0)
800363		9530C311		-2.6 (-19.2)	-12.5 (-24.7)
800366	988282	077B6806		37 (2.8)	16.5 (-8.7)
800368	988285	077B6857		39.6 (4.3)	26.2 (-3.2)
800369	988266	077B1212		-2.6 (-19.4)	-12.3 (-24.8)
800370	988267	077B1216		-4.0 (-20.2)	-15.3 (-26.5)
800371	988286	077B6863		41.9 (5.5)	23.7 (-4.6)
800382	988284	077B6856		37.2 (2.9)	18.1 (-7.8)
800383	988268	077B1227		0.3 (-17.8)	-5.6 (-21.1)
800384	988270	077B1229		24.8 (-4.0)	18.7 (-7.4)
800385	988269	077B1228	WHITE WINE	44.2 (6.8)	34.7 (1.5)
800386	988287	077B6871		43.2 (6.3)	20.1 (-6.7)
800387	988288	077B6887	FLOWER COOLER	39.2 (4.0)	21.2 (-6.0)
800390		9530N1329	SUPER NOVA	13.1 (-10.5)	8.1 (-13.3)
800393	988283	077B6827		41.7 (5.4)	20.5 (-6.4)
800395		931N370	HIGH ALTITUDE	40.0 (4.4)	22.8 (-5.1)
800399		9530C304		0.4 (-17.6)	-5.4 (-20.8)
822212	988291	CAP-075-174R	HEATED	165.0 (73.9)	174.0 (78.9)
822213	988289	077B6894		37 (2.8)	21.6 (-5.8)
822214	988273	077B1309		32.0 (0.0)	17.9 (-7.9)
822223	988274	077B1331		25.7 (-3.5)	8.6 (-13.0)
831931	988272	077B1277		-2.0 (-19.0)	-9.0 (-23.0)
831932		3ART56VAA4		40.0 (4.4)	18.0 (-7.8)
831987	988265	077B0995	RED WINE, CHOCOLATE	57.2 (14.1)	49.6 (9.9)
908854	988290	077B6926		36.3 (2.4)	10.4 (-12.1)
908975	988275	077B1352		-12.1 (-24.7)	-25.1 (-32.0)
911427	988276	077B1354		37.6 (3.1)	26.2 (-3.2)
913382	988277	077B1367		-11.0 (-24.1)	-22.5 (-30.5)
917838	988278	077B1369		0.3 (-17.8)	-14.1 (-25.8)
930794	988279	091X9775		41.5 (5.3)	24.9 (-3.9)
933190	988280	077B3264		41.7 (5.4)	19.4 (-7.1)
942659	988281	077B3315		39.6 (4.3)	26.2 (-3.2)
952478		077B3347		43.2 (6.3)	20.1 (-6.7)
954800		077B3531		41.9 (5.5)	23.7 (-4.6)
958745		3ART55VAA4		39.2 (4.0)	17.6 (-8.0)
958747	988264	077B3548		37.2 (2.9)	18.1 (-7.8)
958857		3ART5VAA198		8.0 (-13.3)	-6.0 (-21.1)
959268	988294	3ART55VAA3		39.6 (4.2)	26.2 (-3.2)
960640	988296	3ART55VAA5		43.1 (6.2)	20.2 (-6.6)
962728		3ART55VAA6		41.8 (5.4)	20.4 (-6.4)
963056		3ART55VAA2		39.2 (4.0)	15.8 (-9.0)

All temps are at mid-point setting #5

All temps advised have a +/- 1.8 to 2 degree variance depending upon control

# MECHANICAL TEMPERATURE CONTROLS

## CHECKING THE CUT IN AND CUT OUT OF THE TEMPERATURE CONTROL

### COIL SENSING



Example of checking coil temperature for a coil sensing thermostat. Position thermometer as close as possible to the control sleeve in the evaporator coil.

### AIR SENSING

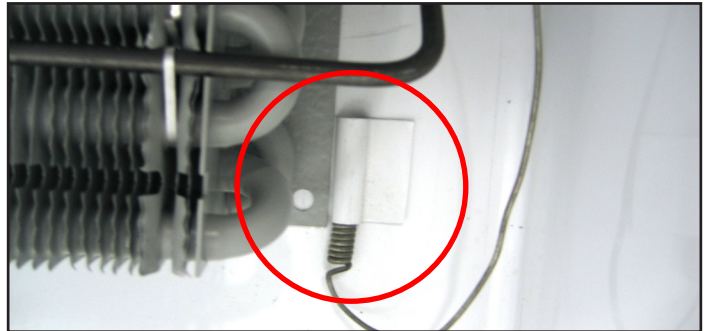

Example of checking air temperature for an air sensing thermostat. Position thermometer as close as possible to the "pig tail" at the end of the thermostat bulb.

## CONDITIONS THAT COULD CAUSE A TEMPERATURE CONTROL MISDIAGNOSIS

- Dirty Condensing Coil
- Bad Door Gasket
- Poor Ventilation / High Ambient Conditions
- Refrigeration System Failure
- Temperature Control Relay

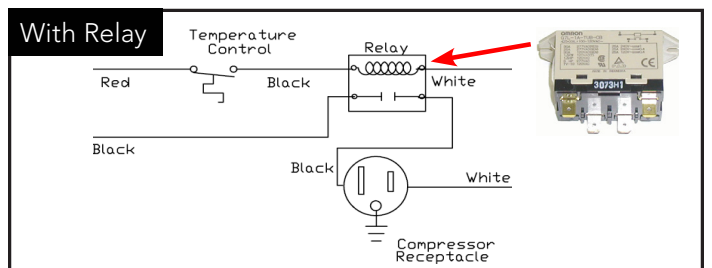
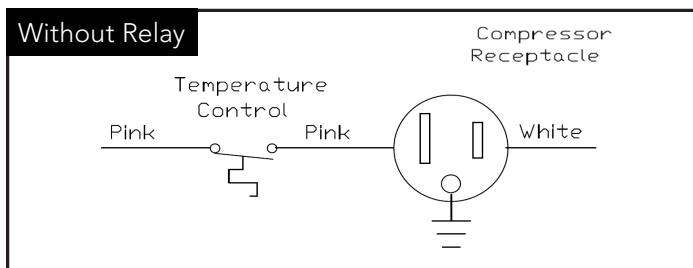
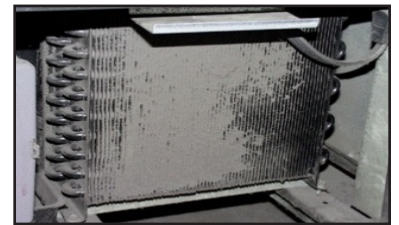

**NOTE:** Wire colors shown are for example only. Reference the Cabinet Wiring Diagram for the correct wire colors.

# MECHANICAL TEMPERATURE CONTROLS

## WHEN TO MAKE AN ADJUSTMENT TO A MECHANICAL TEMPERATURE CONTROL

We advise to make a mechanical temperature control adjustment only for a high altitude location.



## HOW TO ADJUST A MECHANICAL TEMPERATURE CONTROL

### GE TEMPERATURE CONTROL ADJUSTMENT FOR HIGH ALTITUDE APPLICATIONS:

#### REQUIRED TOOLS:

- Jewelers screwdriver (Small screwdriver)

#### GE CONTROL INSTRUCTIONS:

The scale to the right may be used as a guide for measuring degrees of rotation required for altitude correction. See Figure 1. The arrows indicate direction of screw rotation. Turn calibration screw clockwise to obtain warmer operating temperatures.

**STEP 1** - Unplug cooler.

**STEP 2** - Remove the screws that secure the temperature control to the inset box.

**STEP 3** - To make these adjustments it may be necessary to remove the temperature control from the housing.

**NOTE:** You may have to remove the wires attached to the control. Take note as to which wire is on which spade terminal.

**STEP 4** - Pull out gently from cabinet.

**STEP 5** - Each 1/4 turn of the calibration screw is equal to approximately 2 degrees F (1.1 degree C). Do not make more than 3/4 turn. After making adjustment, measure temperature during three cycles before adjusting again.

**NOTE:** Only adjust the screw (small flathead) on the face of the control (next to the cam). See Figure 3.

**STEP 6** - Make sure to reconnect the wires to the proper spade terminal when reinstalling.

Follow the Altitude Correction Table to the right.

#### Scale Guide for Measuring

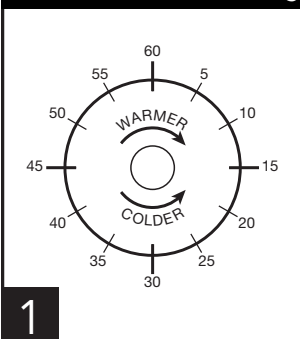

#### Back of Temperature Control

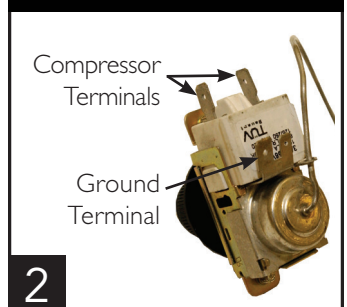

#### Altitude Correction

#### Front of Temperature Control

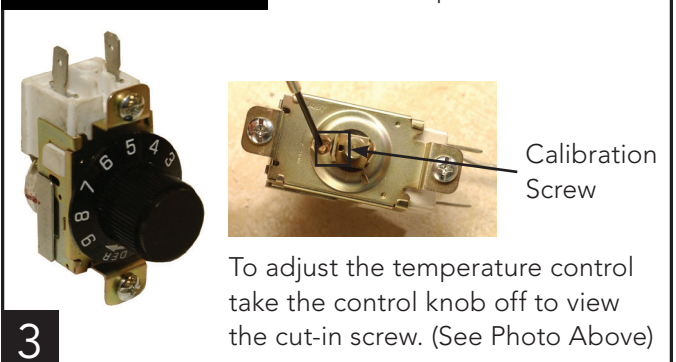

### ALTITUDE CORRECTION TABLE: CALIBRATION SCREW ADJUSTS BOTH CUT-IN AND CUT-OUT

Altitude (Feet / Meters)	Clockwise Turns
2000 / 610	7/60
3000 / 914	11/60
4000 / 1219	15/60
5000 / 1524	19/60
6000 / 1829	23/60
7000 / 2134	27/60
8000 / 2438	30/60
9000 / 2743	34/60
10,000 / 3048	37/60

## MECHANICAL TEMPERATURE CONTROLS

### DANFOSS TEMPERATURE CONTROL ADJUSTMENT FOR HIGH ALTITUDE APPLICATIONS:

#### REQUIRED TOOLS:

- Allen Wrench (5/64")
- Torx Screw (T-7)

#### TERMS:

*Cut-out* - Temperature sensed by the controller that shuts the compressor off.

*Cut-in* - Temperature sensed by the controller that turns the compressor on.

**STEP 1** - Unplug cooler.

**STEP 2** - Remove the screws that secure the temperature control to the inset box.

**STEP 3** - To make these adjustments it may be necessary to remove the temperature control from the housing.

**NOTE:** You may have to remove the wires attached to the control. Take note as to which wire is on which spade terminal.

**STEP 4** - Pull out gently from cabinet.

**NOTE:** Mechanical temperature controllers are affected when functioning at high altitude. The cut-in and cut-out temperatures will be colder than when the controller functions closer to sea level.

**STEP 5** - For high elevation installations, it may be necessary to "warm-up" the set points. To make the adjustment, insert the appropriate tool in each adjustment screw and turn 1/4 of a revolution clockwise (to the right). This procedure will adjust both the cut-in and cut-out about 2°F warmer. (1.1 °C) Do not turn more than one (1) full turn.

**STEP 6** - Make sure to reconnect the wires to the proper spade terminal when reinstalling.

Bottom of Temperature Control

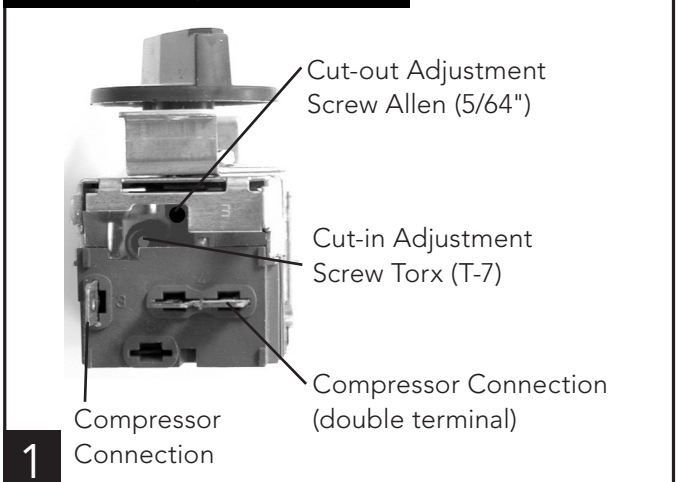



## DEFROST TIMERS

### PARAGON

PARAGON DEFROST TIMER DEFROST TIME CLOCK ADJUSTMENT\_\_\_\_\_37

### GRASSLIN

GRASSLIN DEFROST TIMER DEFROST TIME CLOCK OPERATION\_\_\_\_\_38

### MALLORY

MALLORY DEFROST TIMER DEFROST CONTROLS\_\_\_\_\_45

## DEFROST TIME CLOCK ADJUSTMENT (PARAGON DEFROST TIMER)

### OPERATION INSTRUCTIONS

#### RECOMMENDED DEFROST SETTINGS:

True Manufacturing has factory set your defrost time clock to a recommended time and duration defrost scenario. All refrigeration equipment operating below 30°F (-1.11°C) will accumulate frost on the evaporator coil and will require routine defrost. Your True equipment has been designed for three defrost periods (6:00 a.m., 2:00 p.m. and 10:00 p.m.). If you decide to deviate from these defrost time settings please follow the procedures and adjustment below.

#### Tools Required:

- Slotted Screwdriver

#### Locating The Defrost Timer:

Take off lower grill assembly by removing four (4) corner screws.

#### Single Door Models:

Defrost timer is located in the lower right corner behind the louvered grill.

#### Two Door Models:

Defrost timer is located in the middle of the cabinet, behind the louvered grill. Timer is mounted to the left of the centered ballast box.

#### Three Door Models:

Defrost timer is located on the left upright post behind the louvered grill.

#### Adjusting The Defrost Control

(time initiated, temperature terminated)

Your True freezer contains a defrost system that is temperature terminated, however the time clock has been designed with a time termination back-up so that the defrost period will not exceed twenty minutes. While True recommends 3 defrost periods not to exceed 30 minutes the procedure below should be followed to customize your specific needs.

#### WARNING:

Always follow the manufacturer's recommended settings when programming the amount and duration of the defrost cycles.

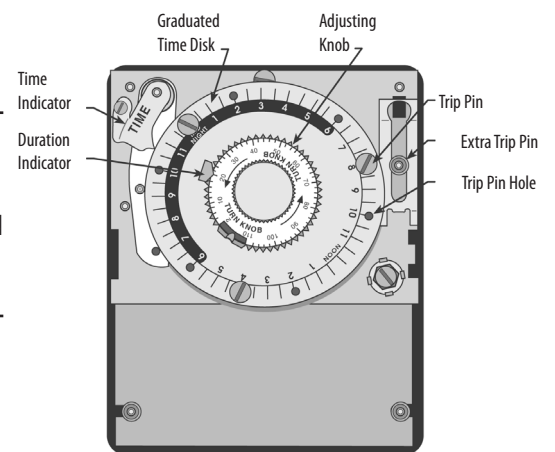

**STEP 1** - Referencing the outer graduated time disk, position the current time of day to align with the "TIME" indicator. To move the graduated time disk, grasp the adjusted knob and turn counter clockwise until the current time of day aligns with the "TIME" indicator.

**STEP 2** - In order to program the time to begin the defrost cycle, insert threaded trip pins into the graduated time disk hole that corresponds to your customized defrost needs.

**STEP 3** - True recommends a 30 minute defrost cycle three times per day. Changing the recommended duration requires pressing down and sliding the copper duration indicator.

## DEFROST TIME CLOCK OPERATION (T-19F/T-19FZ/T-23F) GRASSLIN DEFROST TIMER

### OPERATION INSTRUCTIONS

#### RECOMMENDED DEFROST SETTINGS:

True Manufacturing has factory set your defrost time clock to a recommended time and duration defrost scenario. All refrigeration equipment operating below 30°F (-1.1°C) will accumulate frost on the evaporator coil and will require routine defrost. Your True equipment has been designed for four defrost periods – 2:00 am, 8:00 am, 2:00 pm and 8:00 pm. If you decide to deviate from these defrost time settings please follow the procedures for adjustment below.

#### Tools Required:

- Phillips Screwdriver
- 1/4" Nut Driver or Socket

#### Locating The Defrost Timer:

Take off louvered grill assembly by removing four (4) corner screws.

Defrost timer is located in the lower right corner behind the louvered grill (inside galvanized electrical box).

#### Setting the timer:

(UNPLUG UNIT FROM POWER SUPPLY!)

#### DO NOT SET THE TIME BY ROTATING THE "OUTER" DIAL.

Turn the minute hand clockwise until the time of day on the outer dial is aligned with the triangle marker on the inner dial (two o'clock position). (See image 1).

#### Adjusting The Defrost Timer:

(time initiated, time or temperature terminated).

Your True freezer contains a defrost system that is temperature terminated, however the time clock has been designed with a time termination back-up so that the defrost period will not exceed fifteen minutes. While True requires a minimum 4 defrost periods not to exceed 15 minutes (1 tab), the procedure on this page should be followed to customize your specific needs.

The following procedure may be followed to customize your needs.

High usage, high temperature, and high humidity may require 6 defrost settings per day.

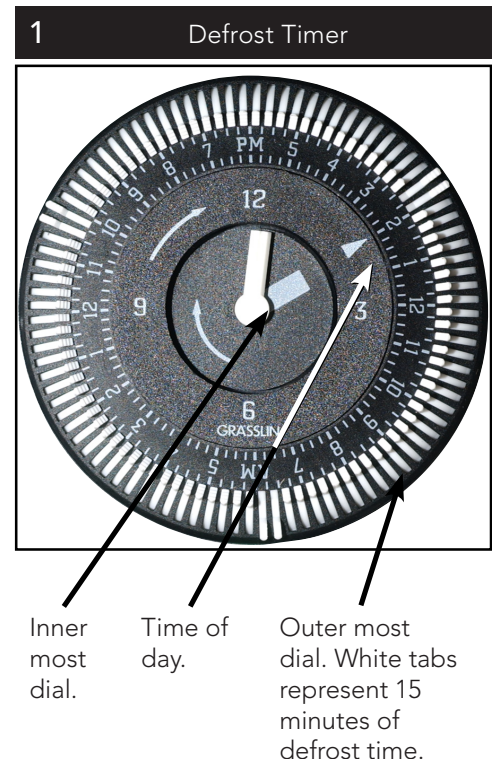

**STEP 1** - The white tabs located on the outmost area of the time clock have been factory set for 2:00 am, 8:00 am, 2:00 pm and 8:00 pm. Each tab represents 15 minutes of defrost time. Notice that at each defrost time one white tab is set for 15 minutes each for a total of 15 minutes of defrost.

**STEP 2** - In order to program the time to begin the defrost cycle, flip the white tabs out to set the defrost time. To eliminate a defrost time flip the white tabs back toward the center of the Defrost Timer.

**STEP 3** - True recommends a 15 minute (1 tab) defrost cycle four times per day.

**NOTICE:**

If timer is not set for a minimum of 4 defrost per day for 15 minutes (1 tab) each, the coil may develop excessive frost. This may lead to system failure and product loss, which is not covered under warranty.

**WARNING:**

Always follow the manufacturer's recommended settings when programming the amount and duration of the defrost cycles.

## DEFROST TIME CLOCK OPERATION (TDBD, TSTD & TCGG) GRASSLIN DEFROST TIMER

### OPERATION INSTRUCTIONS

#### RECOMMENDED DEFROST SETTINGS:

True Manufacturing has factory set your defrost time clock to a recommended time and duration defrost scenario. All refrigeration equipment operating with a gravity coil will accumulate frost on the evaporator coil and will require routine defrost. Your True equipment has been designed for three defrost periods – 6:00 am, 2:00 pm and 10:00 pm. If you decide to deviate from these defrost time settings please follow the procedures for adjustment below.

#### Tools Required:

- Phillips Screwdriver
- 1/4" Nut Driver or Socket

#### Locating The Defrost Timer:

Take off louvered grill assembly by removing four (4) corner screws.

#### TSID and TDBD Models:

The defrost timer is located in the lower left-hand corner, behind the louvered grill.

#### TSID Models:

The defrost timer is located behind the front grill on the lower right-hand side.

#### Setting the timer:

(UNPLUG UNIT FROM POWER SUPPLY!)

#### DO NOT SET THE TIME BY ROTATING THE "OUTER" DIAL.

Turn the minute hand clockwise until the time of day on the outer dial is aligned with the triangle marker on the inner dial (two o'clock position). (See image 2).

1 Defrost Timer Box



2 Defrost Timer

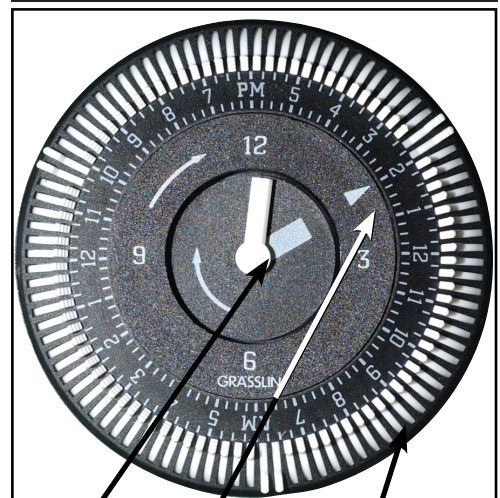

Inner most dial.

Time of day.

Outer most dial. White tabs represent 15 minutes of defrost time.

**Adjusting The Defrost Timer:**

(time initiated, time terminated).

Your True cabinet contains a defrost system that is time terminated. The time clock has been designed so that the defrost period will not exceed sixty minutes. While True requires a minimum 3 defrost periods not to exceed 60 minutes (4 tabs), the procedure on this page should be followed to customize your specific needs.

The following procedure may be followed to customize your needs.

High usage, high temperature, and high humidity may require 4 defrost settings per day.

---

**STEP 1** - The white tabs located on the outmost area of the time clock have been factory set for 6:00 am, 2:00 pm, and 10:00 pm. Each tab represents 15 minutes of defrost time. Notice that at each defrost time four white tabs are set for 15 minutes each, for a total of 60 minutes of defrost.

**STEP 2** - In order to program the time to begin the defrost cycle, flip the white tabs out to set the defrost time. To eliminate a defrost time flip the white tabs back toward the center of the Defrost Timer.

**STEP 3** - True recommends a 60 minute (4 tabs) defrost cycle three times per day.

**NOTICE:**

If timer is not set for a minimum of 3 defrost per day for 60 minutes (4 tabs) each, the coil may develop excessive frost. This may lead to system failure and product loss, which is not covered under warranty.

**WARNING:**

Always follow the manufacturer's recommended settings when programming the amount and duration of the defrost cycles.

# DEFROST TIME CLOCK OPERATION (ALL OTHER FREEZER MODELS) GRASSLIN DEFROST TIMER

## OPERATION INSTRUCTIONS

### RECOMMENDED DEFROST SETTINGS:

True Manufacturing has factory set your defrost time clock to a recommended time and duration defrost scenario. All refrigeration equipment operating below 30°F (-1.1°C) will accumulate frost on the evaporator coil and will require routine defrost. Your True equipment has been designed for three defrost periods – 6:00 am, 2:00 pm and 10:00 pm (the GDM-72F and T-72FG have been designed for four defrost periods – 2:00 am, 8:00 am, 2:00 pm and 8:00 pm). If you decide to deviate from these defrost time settings please follow the procedures for adjustment below.

### Tools Required:

- Phillips Screwdriver
- 1/4" Nut Driver or Socket

### Locating The Defrost Timer:

Take off louvered grill assembly by removing four (4) corner screws.

### TSID and TDBD Models:

The defrost timer is located in the lower left-hand corner, behind the louvered grill.

### TSID Models:

The defrost timer is located behind the front grill on the lower right-hand side.

### Setting the timer:

(UNPLUG UNIT FROM POWER SUPPLY!)

### DO NOT SET THE TIME BY ROTATING THE "OUTER" DIAL.

Turn the minute hand clockwise until the time of day on the outer dial is aligned with the triangle marker on the inner dial (two o'clock position). (See image 2).

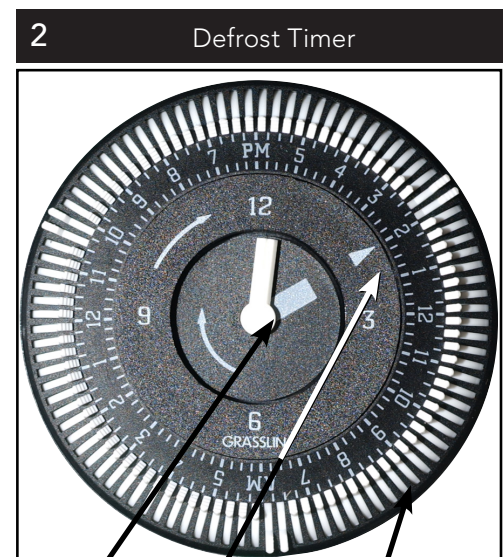
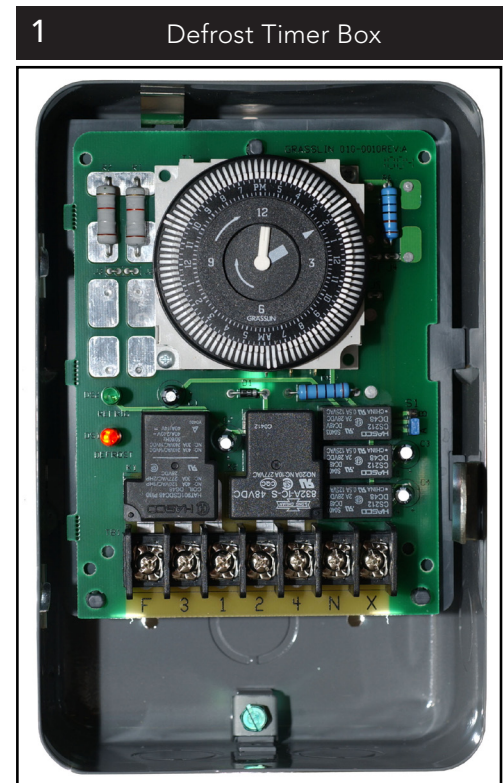

Inner most dial.  
Time of day.  
Outer most dial. White tabs represent 15 minutes of defrost time.

**Adjusting The Defrost Timer:**

(time initiated, time terminated).

Your True cabinet contains a defrost system that is time terminated. The time clock has been designed so that the defrost period will not exceed sixty minutes. While True requires a minimum 3 defrost periods not to exceed 60 minutes (4 tabs), the procedure on this page should be followed to customize your specific needs.

The following procedure may be followed to customize your needs.

High usage, high temperature, and high humidity may require 4 defrost settings per day.

---

**STEP 1** - The white tabs located on the outmost area of the time clock have been factory set for 6:00 am, 2:00 pm, and 10:00 pm (the GDM-72F and T-72FG have been factory set for four times - 2:00 am, 8:00 am, 2:00 pm and 8:00 pm). Each tab represents 15 minutes of defrost time. Notice that at each defrost time four white tabs are set for 15 minutes each, for a total of 60 minutes of defrost.

**STEP 2** - In order to program the time to begin the defrost cycle, flip the white tabs out to set the defrost time. To eliminate a defrost time flip the white tabs back toward the center of the Defrost Timer.

**STEP 3** - True recommends a 60 minute (4 tabs) defrost cycle three times per day (four times per day for GDM-72F and T-72FG).

**NOTICE:**

If timer is not set for a minimum of 3 defrost per day for 60 minutes (4 tabs) each, the coil may develop excessive frost. This may lead to system failure and product loss, which is not covered under warranty.

**WARNING:**

Always follow the manufacturer's recommended settings when programming the amount and duration of the defrost cycles.

# DEFROST CONFIGURATION TO CONVERT FROM PARAGON DEFROST TIMER TO GRASSLIN DEFROST TIMER

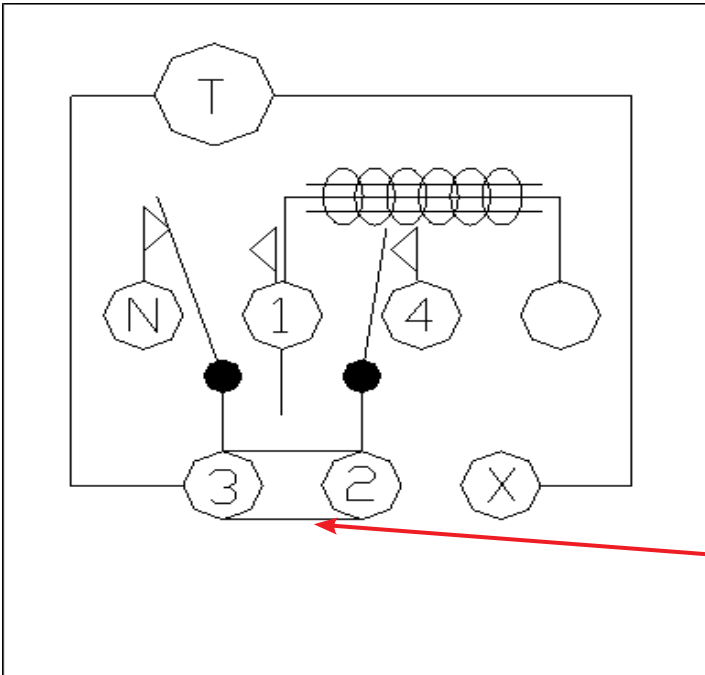

### Paragon Mechanical Timer

- N RED - To Temperature Control (normally closed)
- 1 PINK - To Defrost Heaters (normally open)
- 4 BLACK or TAN - To Evaporator Fan Motors (normally closed)
- 0 PURPLE - Defrost Termination
- 3 BLACK - Line Voltage
- 2 BLACK or TAN - From Door Switch
- X WHITE - Neutral

### Disclaimer:

**\*\*Not All Wire Terminals Are Used In All Applications\*\***  
**\*\*Wire Colors Are Subject To Change\*\***

NOTE: If there is jumper bar between #3 and #2 on the Paragon Timer, you must put a jumper wire between #1 and #2 on the Grasslin timer.

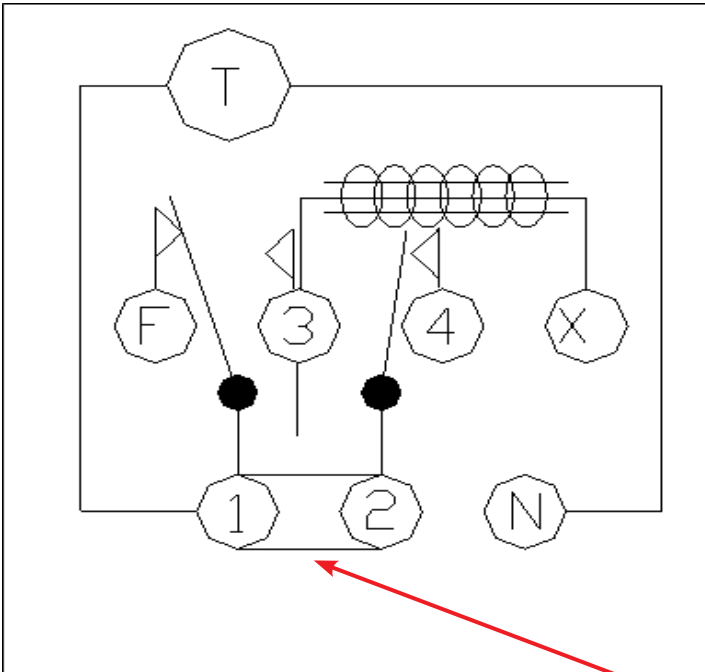

### Grasslin Electronic Timer

- F RED - To Temperature Control (normally closed)
- 3 PINK - To Defrost Heaters (normally open)
- 4 BLACK or TAN - To Evaporator Fan Motors (normally closed)
- X PURPLE - Defrost Termination
- 1 BLACK - Line Voltage
- 2 BLACK or TAN - From Door Switch
- N WHITE - Neutral

### Disclaimer:

**\*\*Not All Wire Terminals Are Used In All Applications\*\***  
**\*\*Wire Colors Are Subject To Change\*\***

\*As shown on the Grasslin Timer\*



NOTE: If there is jumper bar between #3 and #2 on the Paragon Timer, you must put a jumper wire between #1 and #2 on the Grasslin timer.

If you have any questions, please call TRUE technical service.

**DEFROST CONTROLS (MODELS T-GC, TUC/TWT-27F, TUC/TWT-48F, TUC/TWT-60F & TUC/TWT-72F) MALLORY DEFROST TIMER**

**Locating The Defrost Timer:**

Defrost timer can be found directly below the mechanical temperature control.

**Adjusting The Defrost Timer:**

(time initiated, time terminated).

To adjust the defrost cycle time there is only one possible adjustment; Once the cabinet has reach the design temperature, pick the time of the day that you want the unit to defrost. Turn the actuating gear clockwise until the contacts change position initiating the defrost cycle. The next defrost cycle will occur 6-8 hours later, depending upon model.

Like in the time initiated, temperature terminated controls; these systems have a temperature sensor that will disconnect the heaters to keep the cabinet from over heating. However it won't restart the freezing cycle until the control completes the factory set time. These systems are also equipped with temperature sensors to delay the fan motors once the defrost cycle has been completed, to prevent the circulation of warm air inside the cabinet.

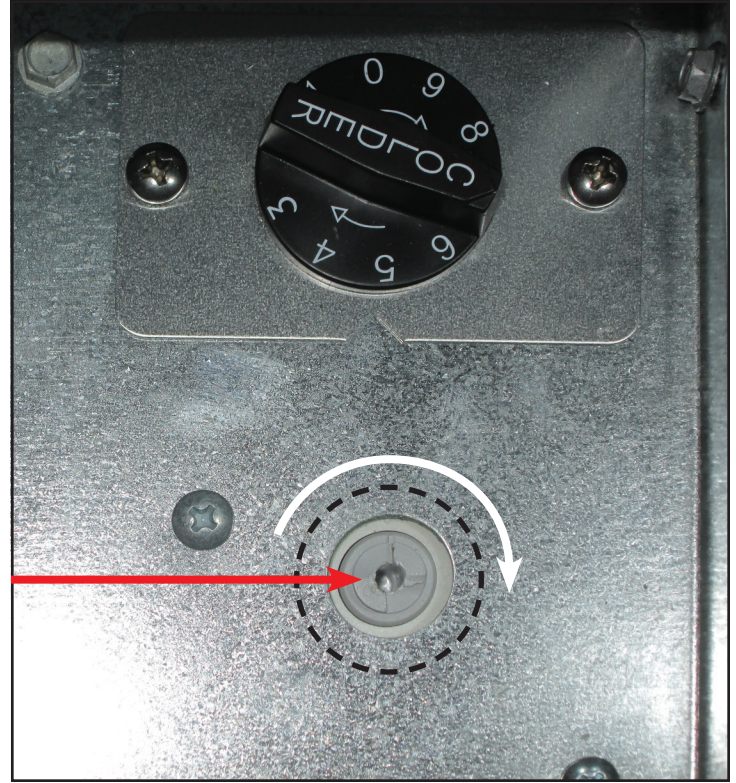

**WIRING**

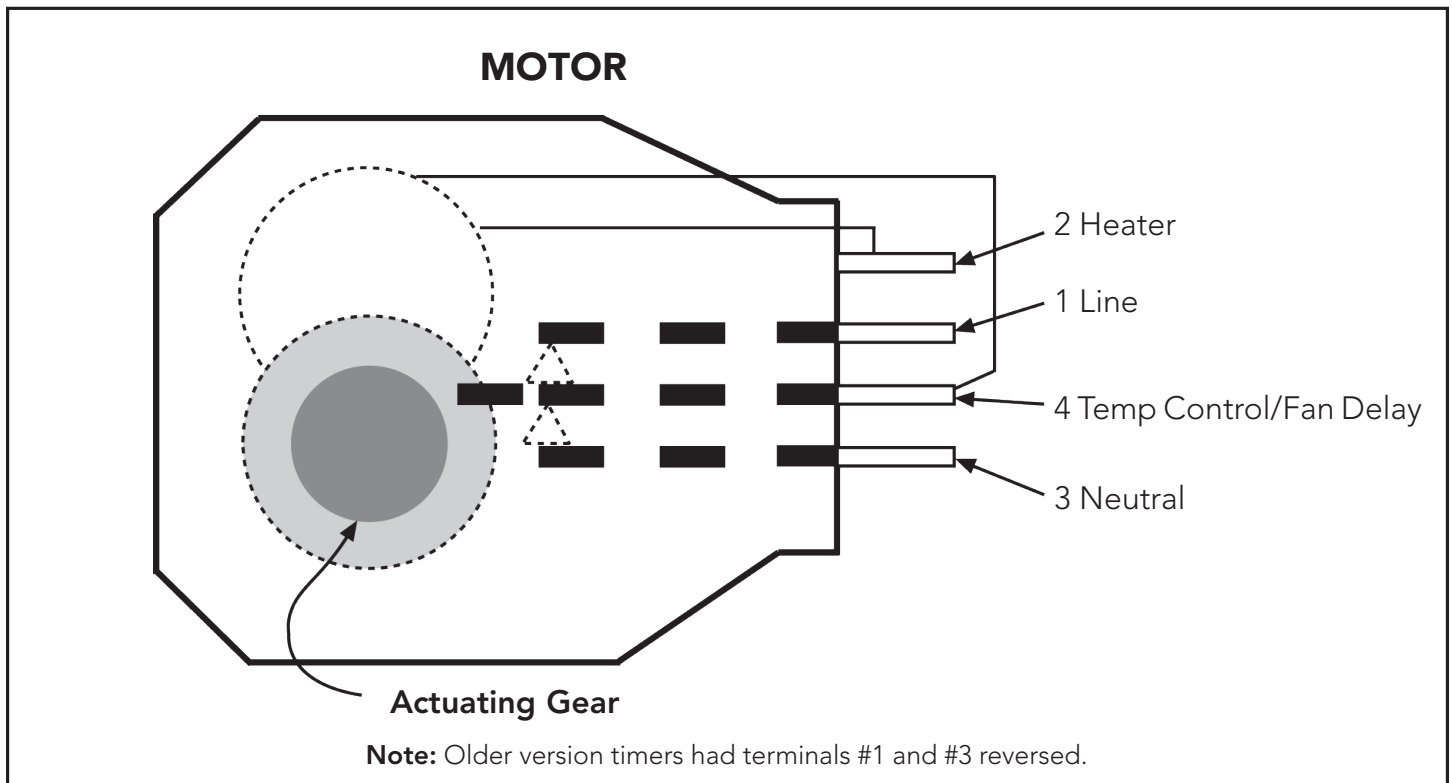



# ELECTRONIC TEMPERATURE CONTROLS

<b>DIXELL</b> _____	<b>49</b>
USING THE DIXELL ELECTRONIC CONTROL _____	50
<b>LAE</b> _____	<b>59</b>
USING THE LAE ELECTRONIC CONTROL _____	62
<b>DANFOSS</b> _____	<b>74</b>
USING THE DANFOSS ELECTRONIC CONTROL _____	77
DANFOSS TROUBLESHOOTING _____	83
<b>SOLLATEK</b> _____	<b>87</b>
USING THE SOLLATEK ELECTRONIC CONTROL _____	88
<b>HST - HEALTH SAFETY TIMER</b> _____	<b>93</b>
USING THE HEALTH SAFETY TIMER _____	96

## **ELECTRONIC TEMPERATURE CONTROLS**

True Manufacturing advises that no electronic control parameter be changed, with the exception of the information provided in the following pages.

Any electronic control parameter that is changed without prior authorization from True Manufacturing may result in a service call that will not be covered under warranty.

If an electronic control has a digital display, the following instructions will advise how to:

- Lock/Unlock the Control (Dixell, LAE, Danfoss)
- View /Modify the Cabinet Holding Temperature (Dixell, LAE, Danfoss)
- Initiate a Manual Defrost (Dixell, LAE, Danfoss)
- Turn the Control On/Off (LAE, Danfoss)
- Change the Display Reading From Fahrenheit to Celsius (LAE, Danfoss)
- Turn the lights On/Off (LAE)
- Increase the Defrost Frequency Interval (Dixell)

## DIXELL ELECTRONIC TEMPERATURE CONTROLS

Control version will vary with model and age of cabinet.

### DIXELL:

**p1** = Thermostat

**p2** = Defrost

**p3** = Display

**p3** probe is not installed and / or activated in all applications. If **p3** is not installed and / or activated, the display probe is **p1**.



### DIXELL PROBES:



# DIXELL ELECTRONIC TEMPERATURE CONTROLS

## HOW TO LOCK / UNLOCK THE KEYS:

### USING THE DIXELL ELECTRONIC CONTROL:

May need to unlock control.

**STEP 1** - Press the (UP) and (DOWN) keys at the same time for more than (3) seconds.

**STEP 2** - The "POF" message will be displayed if the keyboard is locked. At this point, it is only possible to view the set point, MAXIMUM / MINIMUM temperature stored.

**STEP 3** - To unlock the keyboard, press the (UP) and (DOWN) keys at the same time for more than (3) seconds. The "Pon" message will be displayed.

Dixell Control XW60VS



Dixell XR160C

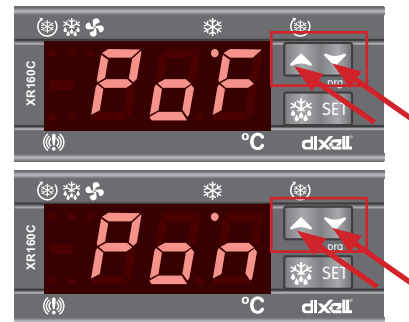

Dixell XR70CX



Dixell XR02CX / XR06CX

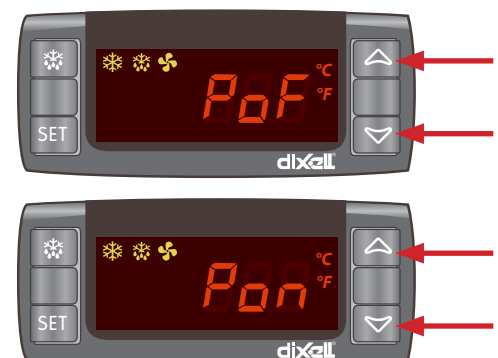

# DIXELL ELECTRONIC TEMPERATURE CONTROLS

## HOW TO SEE AND MODIFY THE SET POINT:

**THE SET POINT IS WHERE THE COMPRESSOR WILL SHUT OFF.**

May need to unlock control.

**STEP 1** - Model XW60VS only push and immediately release the (SET) key. All other models push and hold the (SET) key: The display will show the (SET) point value.

**STEP 2** - The (SET LED) will start blinking.

**STEP 3** - To change the (SET) value, push the (UP) or (DOWN) arrows within (10) seconds.

**STEP 4** - To memorize the new set point value, push the (SET) key again or wait (10) seconds.

### Dixell Control XW60VS

VALUE SHOWN  
MAY NOT BE YOUR  
CURRENT SETTING



### Dixell XR160C

VALUE SHOWN  
MAY NOT BE YOUR  
CURRENT SETTING



### Dixell XR70CX

VALUE SHOWN  
MAY NOT BE YOUR  
CURRENT SETTING



### Dixell XR02CX / XR06CX

VALUE SHOWN  
MAY NOT BE YOUR  
CURRENT SETTING

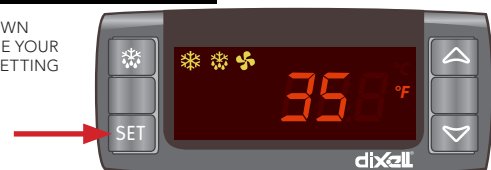

# DIXELL ELECTRONIC TEMPERATURE CONTROLS

## HOW TO SEE "LOD" LOCAL DISPLAY:

THE LOCAL DISPLAY SHOWS WHICH PROBE IS READING.

May need to unlock control.

**STEP 1** - Press and hold the (SET) and (DOWN) arrows at the same time for (7-12) seconds.

**STEP 2** - You should then see (HY).

**STEP 3** - Release the keys.

**STEP 4** - Press the down arrow until you see the letters (LOD), (LD) for models XRO2CX and XRO6CX.

**STEP 5** - Press the (SET) button. You should see P1, P2, P3. This is the probe used for the display. (All probes may not be used in some applications). To change, press the (UP / DOWN) arrow to set a new number and then push the (SET) button to save these changes.

Wait 10 seconds for control to display temperature.

### Dixell Control XW60VS

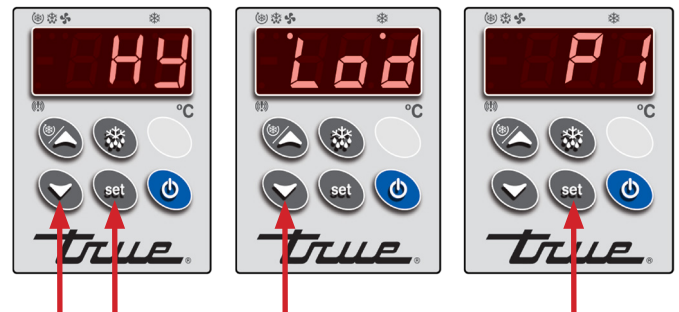

### Dixell XR160C

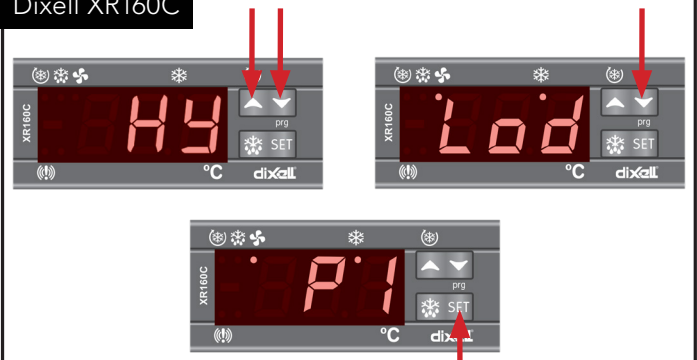

### Dixell XR70CX

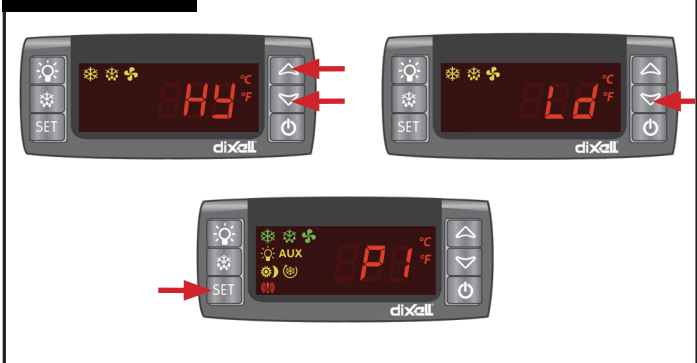

### Dixell XR02CX / XR06CX

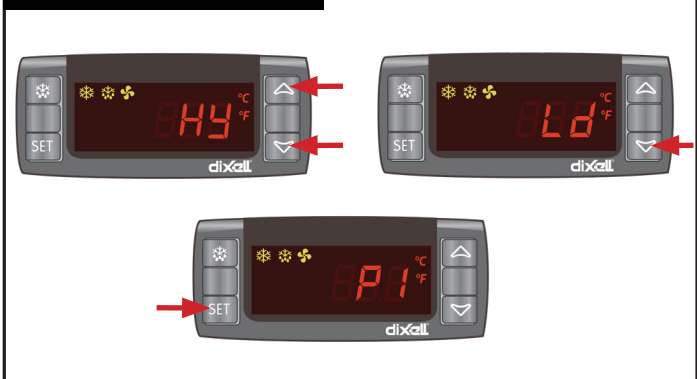

# DIXELL ELECTRONIC TEMPERATURE CONTROLS

## HOW TO SEE "idF" INTERVAL BETWEEN DEFROST:

THE INTERVAL BETWEEN DEFROST TERMINATION IS THE TIME BETWEEN EACH DEFROST CYCLE.

May need to unlock control.

**NOTE:** This interval is started when the cabinet is plugged in or after initiate of manual defrost.

**STEP 1** - Press and hold the (SET) and (DOWN) arrows at the same time for (7-12) seconds.

**STEP 2** - You should then see (HY).

**STEP 3** - Release the keys.

**STEP 4** - Press the down arrow until you see the letters "idF", "id" for models XRO2CX and XRO6CX.

**STEP 5** - Press the (SET) button. You should see the number 6. This is time in hours between each defrost cycle. To change, press the (UP / DOWN) arrow to set a new number and then push the (SET) button to save these changes. Wait 10 seconds for control to display temperature.

**NOTE:** The interval between defrost termination is the time between each defrost cycle.

### Dixell Control XW60VS

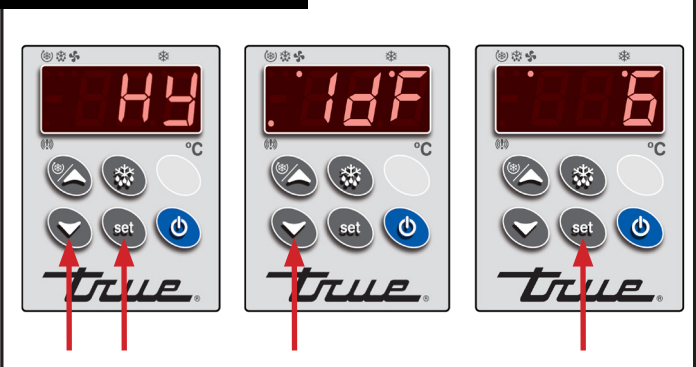

### Dixell XR160C

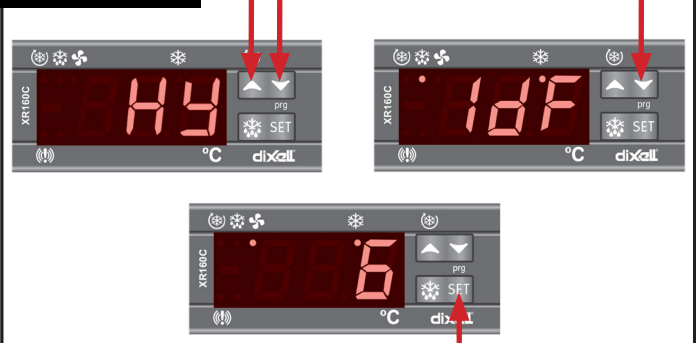

### Dixell XR70CX



### Dixell XR02CX / XR06CX

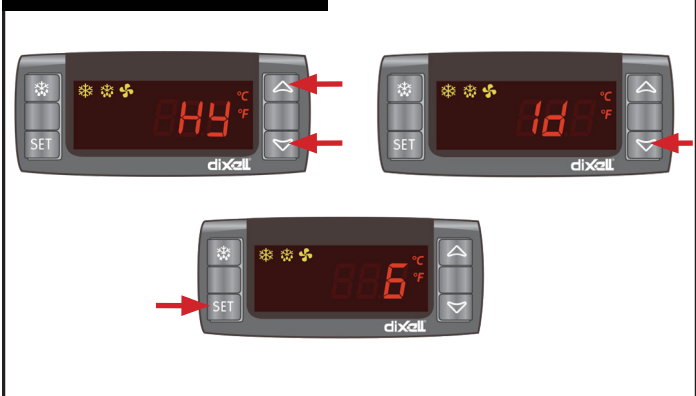

# DIXELL ELECTRONIC TEMPERATURE CONTROLS

## HOW TO START A MANUAL DEFROST:

May need to unlock control.

**STEP 1** - Push the (DEFROST) key for more than (2) seconds and a manual defrost will start.

The "dEF" message will be displayed.

**NOTE:** Defrost will only terminate once a specific preset temperature or a preset time duration is reached.

Dixell Control XW60VS

VALUE SHOWN MAY NOT BE YOUR CURRENT SETTING

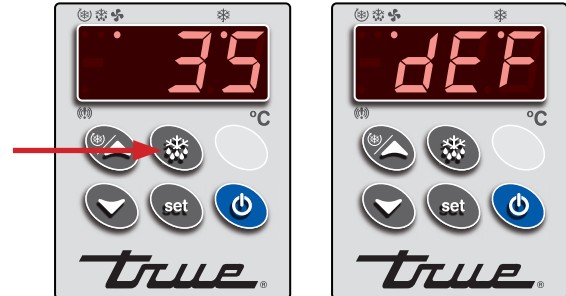

Dixell XR160C

VALUE SHOWN MAY NOT BE YOUR CURRENT SETTING

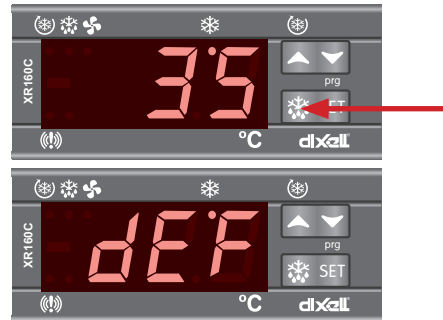

Dixell XR70CX

VALUE SHOWN MAY NOT BE YOUR CURRENT SETTING

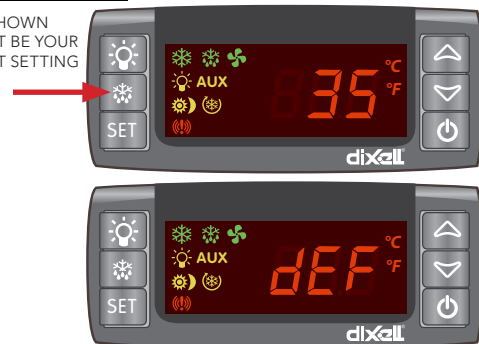

Dixell XR02CX / XR06CX

VALUE SHOWN MAY NOT BE YOUR CURRENT SETTING



## DIXELL ELECTRONIC TEMPERATURE CONTROLS

### HOW TO DOWNLOAD THE CONTROL PARAMETER: BETWEEN DEFROST:

THE PROGRAM PARAMETERS CAN BE DOWNLOADED BY THE USE OF A "HOT KEY."

May need to unlock control.

**NOTE:** These parameters will vary from model to model.

**STEP 1** - Turn controller in the off position or unplug cabinet.

**STEP 2** - Insert "Hot Key" into the back of the controller.

**STEP 3** - Turn on controller or plug in cabinet.

**STEP 4** - "Hot Key" will download automatically once download is complete. Remove "Hot Key".

Dixell Control XW60VS



1

Example of hot key port location shown on model XW60VS. All models use a similar port location.

### DIXELL CONTROL ALARM CODES

## ALARM SIGNALS

MESSAGE	CAUSE
"P1"	Thermostat probe failure
"P2"	Evaporator probe failure
"P3"	Auxiliary probe failure
"HA"	Maximum temperature alarm
"LA"	Minimum temperature alarm
"EE"	Data or memory failure
"dA"	Door switch alarm
"EAL"	External alarm
"BAL"	Serious external alarm
"PAL"	Pressure switch alarm

**NOTE:** To silence alarm, press any button on keypad.

## DIXELL ELECTRONIC TEMPERATURE CONTROLS

### DIXELL NTC PROBES

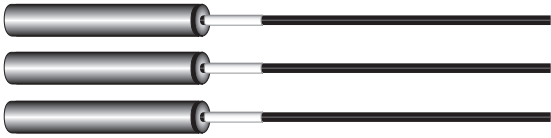

- p1** - Thermostat
- p2** - Defrost
- p3** - Display

#### Checking the probe resistance.

- Verify the probe resistance is accurate at the probe location.
  - Use a calibrated thermometer to check the probe location temperature (coil or air temperature).
  - Disconnect the probe from the controller. The probe cannot be plugged into the controller when measuring resistance.
  - Use a calibrated Ohm meter to measure the resistance of the probe
  - The resistance of the probe should match the associated temperature from the above table.
- Fill a cup full of ice water (use a lot of ice). Put the probe into the ice bath, stir for 1 minute, then measure the resistance with a calibrated Ohm meter. Make sure to keep the probe in the center of the cup.
  - The resistance of the probe should match the associated temperature at 32°F / 0°C degrees as shown in the above table.

Temperature		Resistance
C	F	K-ohm
-50	-58	329.50
-45	-50	247.70
-40	-40	188.50
-35	-31	144.10
-30	-22	111.30
-25	-12.5	86.43
-20	-4	66.77
-15	5	53.41
-10	14	42.47
-5	23	33.90
0	32	27.28
5	41	22.05
10	50	17.96
15	59	14.69
20	68	12.09
25	77	10.00
30	86	8.31
35	95	6.94
40	104	5.83
45	113	4.91
50	122	4.16
55	131	3.54
60	140	3.02
65	149	2.59
70	158	2.23
75	167	1.92
80	176	1.67
85	185	1.45
90	194	1.27
95	203	1.11
100	212	0.97
105	221	0.86
110	230	0.76
		0.53

# DIXELL ELECTRONIC TEMPERATURE CONTROLS

## DIAGNOSTIC FLOWCHART FOR ELECTRONIC CONTROLS WITH DIGITAL DISPLAYS

**Concern:** Electronic Control Display Temperature does not match the cabinet temperature

**NOTE:** The temperatures may reflect the refrigeration cycle determined by a set point and differential or it may show an average temperature. The temperatures are also effected by a defrost cycle and the open and closing of the door. The most accurate temperature on a cabinets operation is to verify the product temperature.

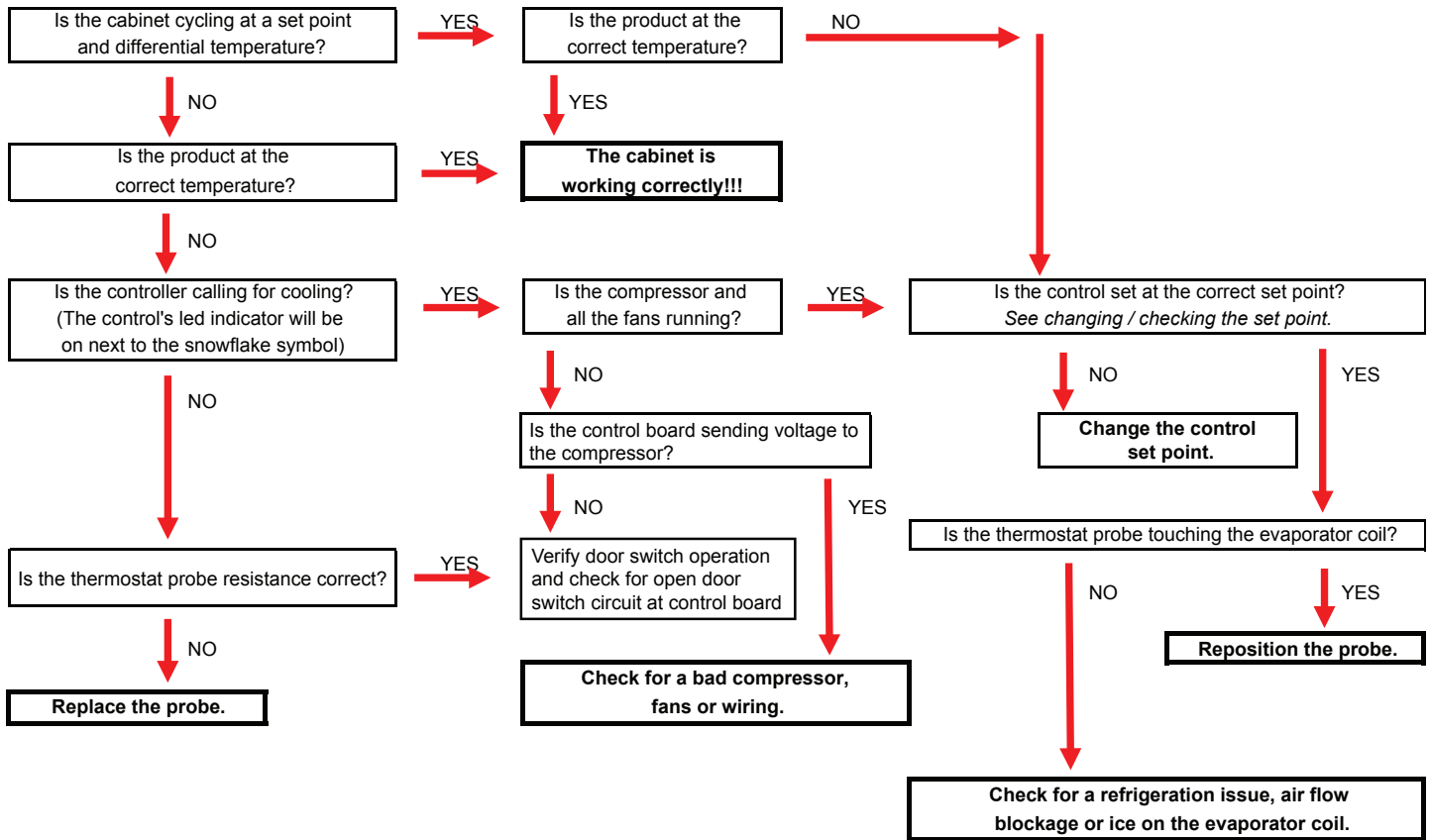



## LAE ELECTRONIC TEMPERATURE CONTROLS

Control version will vary with model and age of cabinet.

### LAE:

**t1** = Thermostat

**t2** = Defrost

**t3** = Display

t3 probe is not installed and / or activated in all applications if t3 is not installed and / or activated, the display probe is t1.



With remote control board.



### LAE CURRENT PROBES:

**GRAY** - Thermostat

**BLUE** - Defrost

**YELLOW** - Display

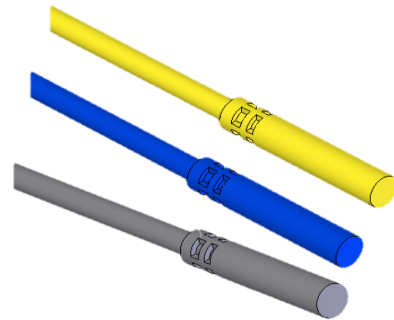

### LAE PRIOR PROBES:

Probes are identical.

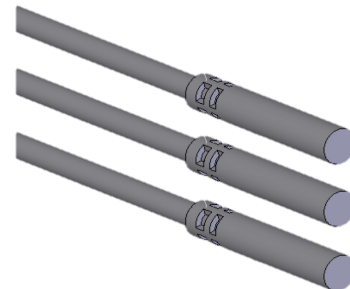

# LAE ELECTRONIC TEMPERATURE CONTROLS

## PRODUCT ADVISEMENT

### DETERMINING THE TYPE OF ELECTRONIC CONTROL DISPLAY

#### Reason for Adviseament

Both Danfoss and LAE electronic controls utilize similar digital displays.

To provide the visual differences and operations between the displays used for the LAE Electronic Control and the Danfoss Electronic control.

**NOTE:** Displays do not interchange with each other due to wiring and programming limitations.

#### DISPLAY FOR LAE CONTROL

Alarm Symbol

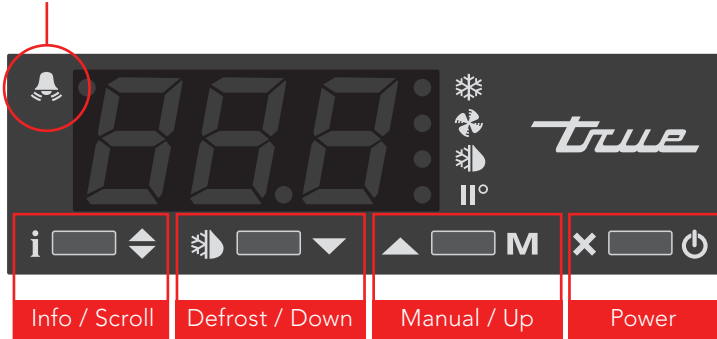

LAE electronic control board

#### DISPLAY FOR DANFOSS CONTROL

No Alarm Symbol

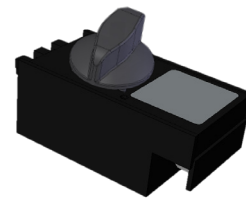
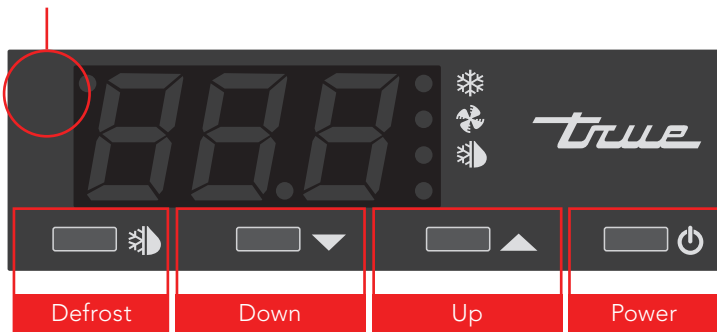

Danfoss electronic control board



Previous Danfoss display

# LAE ELECTRONIC TEMPERATURE CONTROLS

## LAE CONTROL LEGEND



	Compressor Running		Info/Set Point		Manual Activation/Up Arrow
	Evaporator Fan Running		Manual Defrost/Down Arrow		Stand-By/Cancel
	Cabinet in Defrost				
	Activation of 2 <sup>nd</sup> Parameter Set				
	Alarm				

## DISPLAY CODES

Display	Definition	Display	Definition
<i>dEF</i>	Defrost in progress	<i>hi</i>	Room high temperature alarm
<i>oFF</i>	Controller in stand-by	<i>Lo</i>	Room low temperature alarm
<i>do</i>	Door open alarm	<i>E1</i>	Probe T1 failure
<i>t1</i>	Instant Probe 1 temperature	<i>E2</i>	Probe T2 failure
<i>t2</i>	Instant Probe 2 temperature	<i>E3</i>	Probe T3 failure
<i>t3</i>	Instant Probe 3 temperature	<i>th ,</i>	Maximum probe 1 temperature recorded
<i>n in</i>	Minutes of the Real Time Clock	<i>tLo</i>	Minimum probe 1 temperature recorded
<i>hr5</i>	Hours of the Real Time Clock	<i>Loc</i>	Keypad state lock

# LAE ELECTRONIC TEMPERATURE CONTROLS

## LAE CONTROL LEGEND



- Compressor Running
- Evaporator Fan Running
- Cabinet in Defrost
- Activation of 2nd Parameter Set
- Alarm
- Info/Set Point
- Manual Activation/Up Arrow
- Manual Defrost/Down Arrow
- Stand-By/Cancel

### Lock/Unlock the Control

1. Press info to show t1.



2. Press the down arrow to show Loc.



3. Press and hold info to show the current lock status.  
**DO NOT RELEASE THE BUTTON!**



YES = Locked



no = Unlocked

4. Press the arrows to change the lock setting.



5. Release all buttons and wait for the control to display the cabinet temperature.

### Turn Off/On the Control

Turning off the control will deactivate all electronic components connected to the control. The lights will remain powered.

**CAUTION** – Turning off the control will not shut off power to the cabinet. Be sure to remove power to the cabinet prior to servicing.

#### Turn Off

Press and hold cancel until the display shows **oFF**.



#### Turn On

Press and hold cancel until the display shows **on**.



# LAE ELECTRONIC TEMPERATURE CONTROLS

## LAE CONTROL LEGEND



	Compressor Running		Info/Set Point		Manual Activation/ Up Arrow
	Evaporator Fan Running		Manual Defrost/ Down Arrow		Stand-By/ Cancel
	Cabinet in Defrost				
	Activation of 2 <sup>nd</sup> Parameter Set				
	Alarm				

### Change the Set Point

Changing the set point adjusts the cabinet temperature to keep optimal product temperature.

1. Press and hold info until the display shows the current set point. **DO NOT RELEASE THE BUTTON!**



2. While holding info, press the up or down arrows to adjust the setting.



3. Release all buttons and wait for the control to display the current cabinet temperature.

### Initiate Manual Defrost

A manual defrost clears accumulated frost and ice from the evaporator coil. The defrost will only terminate when a specific preset temperature or duration has been met.

Press Manual Defrost until the display shows **deF**.



# LAE ELECTRONIC TEMPERATURE CONTROLS

## LAE CONTROL LEGEND



	Compressor Running		Info/Set Point		Manual Activation/Up Arrow
	Evaporator Fan Running		Manual Defrost/Down Arrow		Stand-By/Cancel
	Cabinet in Defrost				
	Activation of 2nd Parameter Set				
	Alarm				

### Change Defrost Intervals

The defrost interval is the duration between defrost cycles.

**NOTE:** The defrost interval **can only be changed** if the defrost mode parameter **dFm** is set for **tim** or **Fro**.

1. Press and hold both info and cancel until the display shows **MdL** or **SPL**.



2. Press the up arrow until the display shows **dFt**.



3. Press and hold info until the display shows the current defrost interval time.

**DO NOT RELEASE THE BUTTON!**



4. While holding info, the up or down arrows to adjust the setting.



5. Release all buttons and wait for the control to display the current cabinet temperature.

### Change Display Readout

The display can show the temperature in either Fahrenheit or Celsius.

1. Press and hold both info and cancel until the display shows **MdL** or **SPL**.



2. Press the down arrow until the display shows **ScL**.



3. Press and hold info until the display shows the current system of measure.

**DO NOT RELEASE THE BUTTON!**

- °F: Fahrenheit (no decimal)
- 1°C: Celsius (0.1 precision)
- 2°C: Celsius (no decimal)



Fahrenheit



Celsius

4. While holding info, press the up or down arrow to change the system of measure.



5. Release all buttons and wait for the control to display the current cabinet temperature.

# LAE ELECTRONIC TEMPERATURE CONTROLS

## LAE CONTROL LEGEND



	Compressor Running		
	Evaporator Fan Running		
	Cabinet in Defrost		
	Activation of 2 <sup>nd</sup> Parameter Set		
	Alarm		

### Display Probe Temperatures

The display shows the temperature probe readings in different locations of the cabinet.

1. Press info to show **t1**.



2. Press and hold info to show the current **t1** probe temperature.



3. Release info to show **t2**.



4. Press and hold info to show the current **t2** probe temperature.



5. Release info to show **t3**.



6. Press and hold info to show the current **t3** probe temperature.  
**NOTE:** If the T3 probe is not activated, **t3** will not appear.



7. Release all buttons and wait for the control to display the current cabinet temperature.

# LAE ELECTRONIC TEMPERATURE CONTROLS

## Alarms

Please note the alarm values shown may vary by model. Please see "Adjust Temperature Alarm Ranges" to adjust the temperature alarms for your application.

### Temperature Alarms

#### Please Be Advised

- The high temperature alarm typically triggers during the unit's initial startup. Silence the alarm as described below; the display will continue flashing **hi** until the alarm condition has been resolved as described below.
- If an alarm has been **silenced but the reason for the alarm persists**, the control will **sound a 20 second alert every 60 minutes** until the alarm condition has been resolved as described below.

#### High Temperature Alarm



An audio/visual alarm that warns when the internal cabinet temperature rises above accepted parameters.

##### Why It Occurs

If the internal cabinet temperature reads  $\geq 46^{\circ}\text{F}$  ( $8^{\circ}\text{C}$ ) for  $\geq 5$  minutes, the control emits a series of beeps and the display flashes **hi**.

##### Silencing the Alarm

Press **ANY** button to silence the alarm. The display will continue to flash **hi** until the internal cabinet temperature reads  $< 46^{\circ}\text{F}$  ( $8^{\circ}\text{C}$ ).

#### Low Temperature Alarm



An audio/visual alarm that warns when the internal cabinet temperature drops below accepted parameters.

##### Why It Occurs

If the internal cabinet temperature reads  $\leq 36^{\circ}\text{F}$  ( $2^{\circ}\text{C}$ ) for  $\geq 5$  minutes, the control emits a series of beeps and the display flashes **Lo**.

##### Silencing the Alarm

Press **ANY** button to silence the alarm. The display will continue to flash **Lo** until the internal cabinet temperature reads  $> 36^{\circ}\text{F}$  ( $2^{\circ}\text{C}$ ).

### Door Open Alarm



An audio/visual alarm that warns when the door remains open longer than accepted parameters.

##### Why It Occurs

If the door remains open for  $\geq 60$  seconds, the control emits a series of beeps and the display flashes **do**.

##### Silencing the Alarm

Shut the door to stop the alarm. Alternately, press **ANY** button to silence the alarm; the display will continue to flash **do** until the door closes.

# LAE ELECTRONIC TEMPERATURE CONTROLS

## LAE CONTROL LEGEND



	Compressor Running		Info/Set Point		Manual Activation/Up Arrow
	Evaporator Fan Running		Manual Defrost/Down Arrow		Stand-By/Cancel
	Cabinet in Defrost				
	Activation of 2 <sup>nd</sup> Parameter Set				
	Alarm				

### Adjust Temperature Alarm Ranges

The temperature alarm ranges are adjustable for different customer applications. Please note the values shown are Fahrenheit.

**NOTE:** The control will lock after a short period of inactivity. Unlock the display and press the up arrow to scroll to the required parameter. If the control skips past the necessary parameter, press the down arrow to scroll back.

#### Step 1: Change Alarm Mode (AtM)

1. Press and hold both info and cancel until the display shows **MdL** or **SPL**.



2. Press the up arrow until the display shows **AtM**.



3. While the display shows **AtM** press and hold info to show the current setting.  
**DO NOT RELEASE THE BUTTON!**



4. While holding info , press the down arrow until the display shows **AbS** (alarm is an absolute number).



5. Release all buttons to show **ALA**. Proceed to step 2.

#### Step 2: Change Low Alarm Setting (ALA)

1. While the display shows **ALA**, press and hold info to show the current setting.  
**DO NOT RELEASE THE BUTTON!**



2. While holding info, press the up or down arrows to change the current setting.  
**RECOMMENDED:** Be sure the low alarm setting is **at least 1° colder** than the Cut-Out temperature to prevent a false alarm.



3. Release all buttons to show **AhA**. Proceed to step 3.

# LAE ELECTRONIC TEMPERATURE CONTROLS

## LAE CONTROL LEGEND



- Compressor Running
- Evaporator Fan Running
- Cabinet in Defrost
- Activation of 2nd Parameter Set
- Alarm
- Info/Set Point
- Manual Activation/Up Arrow
- Manual Defrost/Down Arrow
- Stand-By/Cancel

### Step 3: Change High Alarm Setting (AhA)

1. While the display shows **AhA**, press and hold info to show the current setting.

**DO NOT RELEASE THE BUTTON!**



2. While holding info, press the up or down arrows to change the current setting.

**RECOMMENDED:** Be sure the high alarm setting is at least 1° warmer than the Cut-In temperature to prevent a false alarm.



3. Release all buttons. Proceed to step 4.

### Step 4: Change Alarm Delay (Atd)

1. Press info until the display shows **Atd**.



2. While the display shows **Atd**, press and hold info to show the current setting.

**DO NOT RELEASE THE BUTTON!**



3. While holding info, press the up or down arrows to change the current setting.

**NOTE:** Alarm delay is measured in minutes.

**RECOMMENDED:** Be sure the time delay is at least 5 minutes to prevent a false alarm.



4. Release all buttons and wait for the control to display the current cabinet temperature.

# LAE ELECTRONIC TEMPERATURE CONTROLS

## LAE CONTROL LEGEND



	Compressor Running		Info/Set Point		Manual Activation/Up Arrow
	Evaporator Fan Running		Manual Defrost/Down Arrow		Stand-By/Cancel
	Cabinet in Defrost				
	Activation of 2 <sup>nd</sup> Parameter Set				
	Alarm				

## High (thi) & Low (tLo) Temperature Log

The High/Low Temperature Log allows user to see maximum and minimum temperatures recorded since the log was last reset.

**RECOMMENDED:** The control typically records the **thi** during the initial startup. Reset the **thi** log after 24 hours of operation.

### Viewing the Log

1. Tap info until the display shows either **thi** or **tLo**.



2. Press and hold info until the display shows the logged maximum or minimum temperature.



### Reset the Log

1. Tap info until the display shows either **thi** or **tLo**.



2. Press and hold info until the display shows the logged temperature.

**DO NOT RELEASE THE BUTTON!**

3. Tap cancel to set the log to the current internal cabinet temperature.



## LAE ELECTRONIC TEMPERATURE CONTROLS

Control version will vary with model and age of cabinet.

### LAE:

- t1 = Thermostat
- t2 = Defrost
- t3 = Display

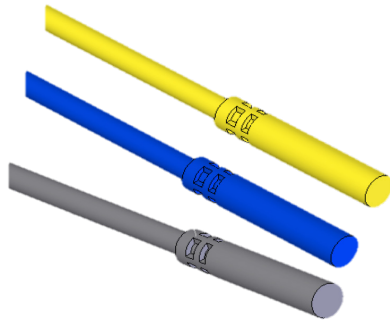

### Checking the probe resistance.

- Verify the probe resistance is accurate at the probe location.
  - Use a calibrated thermometer to check the probe location temperature (coil or air temperature).
  - Disconnect the probe from the controller. The probe cannot be plugged into the controller when measuring resistance.
  - Use a calibrated Ohm meter to measure the resistance of the probe
  - The resistance of the probe should match the associated temperature from the above table.
- Fill a cup full of ice water (use a lot of ice). Put the probe into the ice bath, stir for 1 minute, then measure the resistance with a calibrated Ohm meter. Make sure to keep the probe in the center of the cup.
  - The resistance of the probe should match the associated temperature at 32°F / 0°C degrees as shown in the above table.

Temperature		Resistance
C	F	K-ohm
-40	-40	195.65
-35	-31	148.17
-30	-22	113.35
-25	-13	87.56
-20	-4	68.24
-15	5	53.65
-10	14	42.51
-5	23	33.89
0	32	27.22
5	41	22.02
10	50	17.93
15	59	14.67
20	68	12.08
25	77	10.00
30	86	8.32
35	95	6.95
40	104	5.83
45	113	4.92
50	122	4.16
55	131	3.54
60	140	3.01
65	149	2.59
70	158	2.23
75	167	1.93
80	176	1.67
85	185	1.45
90	194	1.27
95	203	1.15
100	212	0.97
105	221	0.86
110	230	0.76
115	239	0.67
120	248	0.60
125	257	0.53

# LAE ELECTRONIC TEMPERATURE CONTROLS

## DIAGNOSTIC FLOWCHART FOR ELECTRONIC CONTROLS WITH DIGITAL DISPLAYS

**Concern:** Electronic Control Display Temperature does not match the cabinet temperature

**NOTE:** The temperatures may reflect the refrigeration cycle determined by a set point and differential or it may show an average temperature. The temperatures are also effected by a defrost cycle and the open and closing of the door. The most accurate temperature on a cabinets operation is to verify the product temperature.

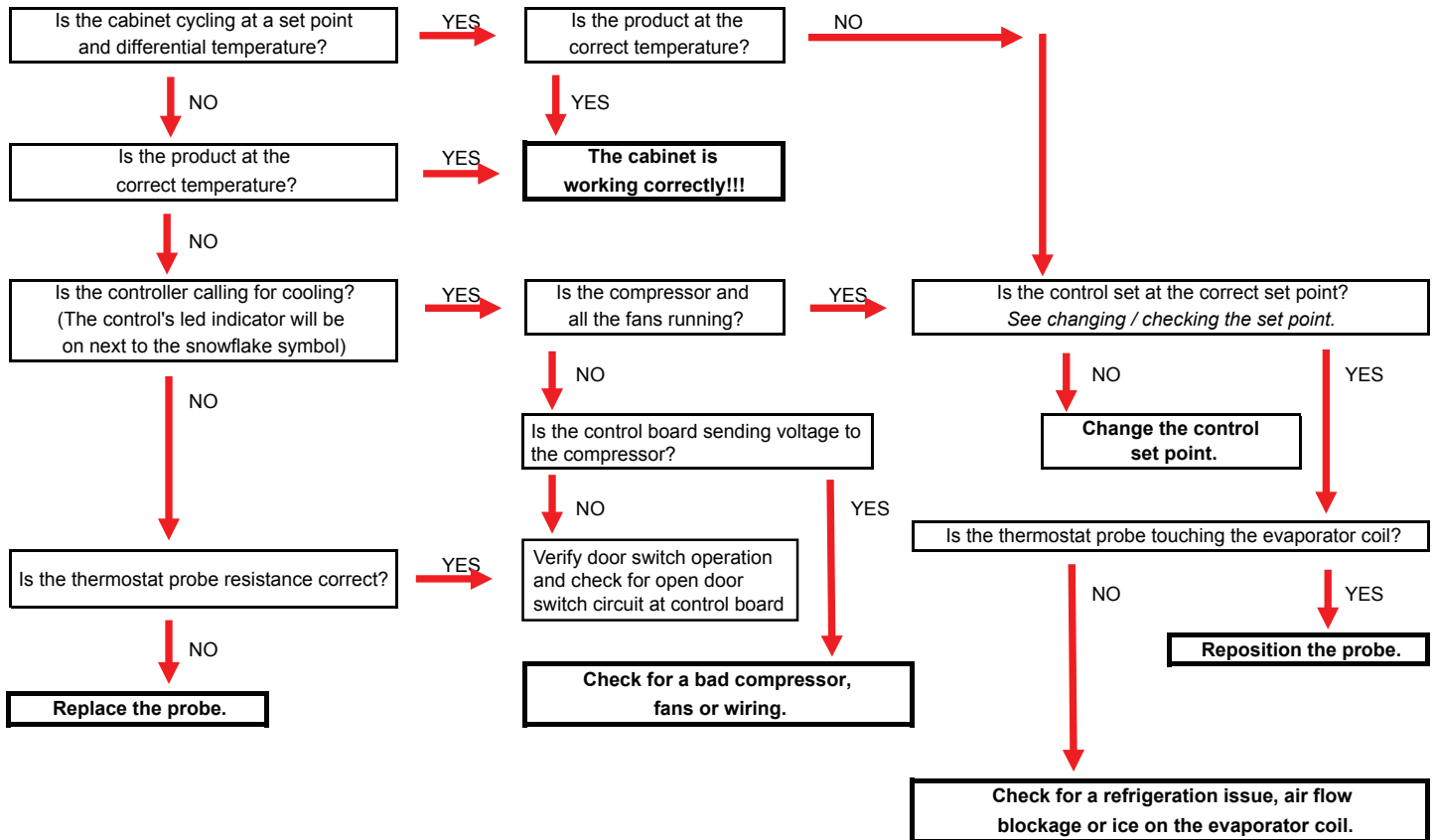

# LAE ELECTRONIC TEMPERATURE CONTROLS

980452

## PRODUCT ADVISEMENT

**LAE ELECTRONIC CONTROL CHANGE FROM MODEL AR1-28 AND AR2-28 TO MODEL BR1-28.**

**REASON FOR ADVISEMENT:** LAE Electronic Control model update will change the display, connecting cable, module, wiring and programming\*. This advisement only references new controls that were ordered for a specific serial number of unit. This advisement is NOT for the installation of a control deemed "universal" as per True Manufacturing.

**NOTE:** Probes are included with the kit but do not need to be installed as existing probes are compatible, unless they are defective.

**WARNING:** Wiring of the new control has changed from the previous version. See wiring locations below.

**DO NOT** simply remove the six terminal green connector from the previous control and place it on the new control, as wire locations have changed and an additional two terminal green connector will be required for proper wire placement (included in kit).

\*Control is pre-programmed from the factory for only this model and serial number of cabinet.

Wire Description	AR2 Wire Location	BR1 Wire Location
Aux 2	1 and 2	1 and 2
Aux 1	6	4
Def	7	5 or 6
Fan	8	7
Line	9	8 or 9
Comp	10 or 11	10 or 11
Neutral	14 - 19	13 - 18
T3 probe	26	23
Common for T3	27	24
Common for T1	27	21
T1 Probe	28	20
Common for T2	29	21
Common for DI1	32	27
T2 Probe	30	22
DI1 (door)	31	25
Common for DI2	32	27
DI2	33	26
SSR-	n/a	28
SSR+	n/a	29

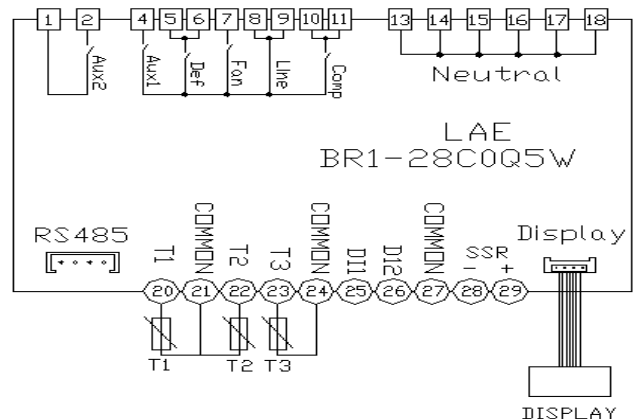
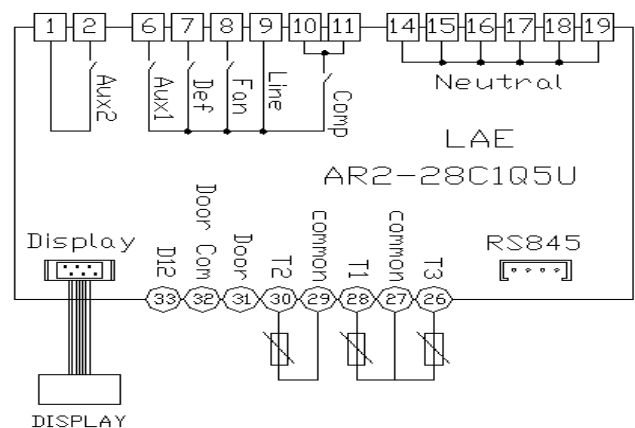



# DANFOSS ELECTRONIC TEMPERATURE CONTROLS

Control version will vary with model and age of cabinet.

**DANFOSS:**

thermostat probe = return air  
defrost probe = coil

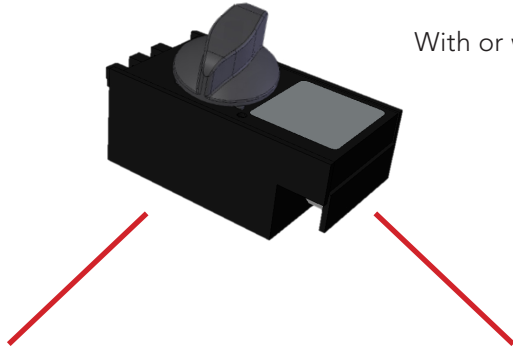

With or without optional remote display.

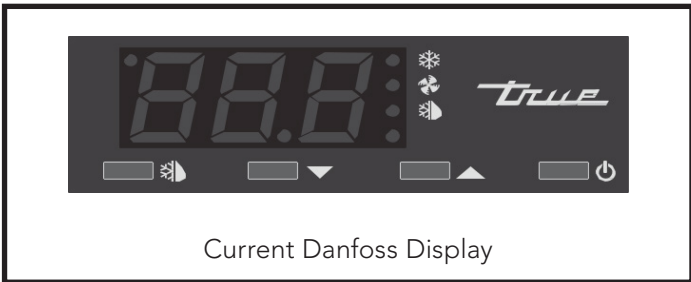

Current Danfoss Display



Previous Danfoss Displays



With or without optional remote control board.

**DANFOSS ELECTRONIC PROBES:**

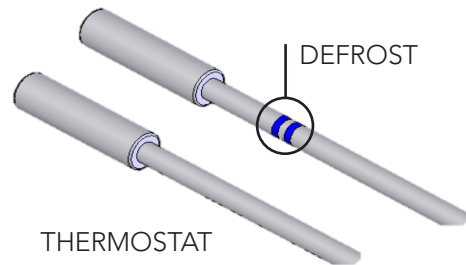

# DANFOSS ELECTRONIC TEMPERATURE CONTROLS

## PRODUCT ADVISEMENT

### DETERMINING THE TYPE OF ELECTRONIC CONTROL DISPLAY

#### Reason for Adviseament

Both Danfoss and LAE electronic controls utilize similar digital displays.

To provide the visual differences and operations between the displays used for the LAE Electronic Control and the Danfoss Electronic control.

**NOTE:** Displays do not interchange with each other due to wiring and programming limitations.

#### DISPLAY FOR LAE CONTROL

Alarm Symbol

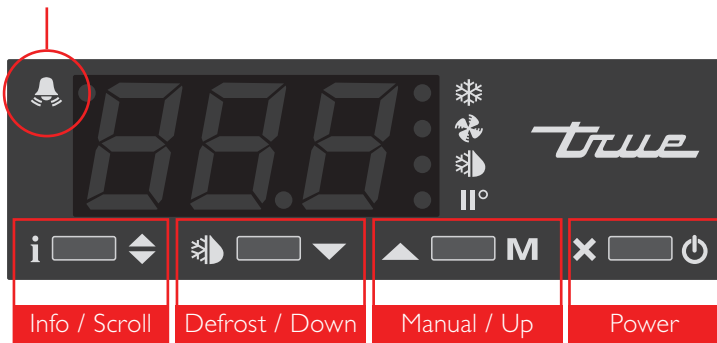

LAE electronic control board

#### DISPLAY FOR DANFOSS CONTROL

No Alarm Symbol

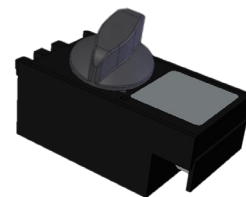
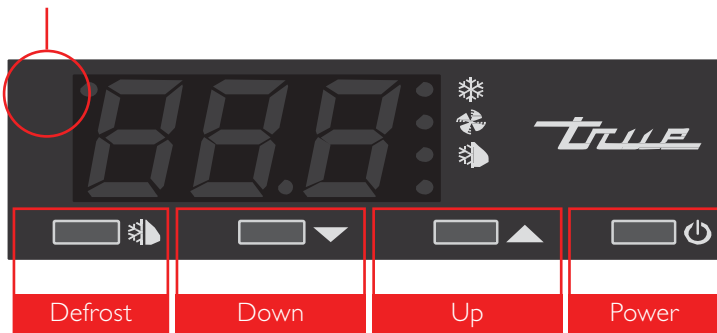

Danfoss electronic control board



Previous Danfoss display

## DANFOSS ELECTRONIC TEMPERATURE CONTROLS

ALARMS	ALARM TYPE	CODE SHOWN	VALUE
	Sensor 1 defect	E1	--
	Sensor 2 defect	E2	--
	Compressor fault	E4	--
	Heater fault	E5	--
	Pot fault	E6	--
	Supply voltage low	ULo	--
	Supply voltage high	UHi	--
	High temperature alarm	Hi	Temperature
	Low temperature alarm	Lo	Temperature
	Communication error	E13	--

CURRENT CONTROL DISPLAY



PREVIOUS CONTROL DISPLAY



# DANFOSS ELECTRONIC TEMPERATURE CONTROLS

## HOW TO USE THE DANFOSS ELECTRONIC CONTROL

### ELECTRONIC TEMPERATURE CONTROLS - DANFOSS:

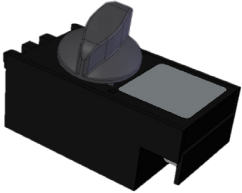

#### USING A DANFOSS ELECTRONIC CONTROL WITH DIGITAL DISPLAY:

**STEP 1** - Press both buttons to power on the temperature control. See Figure 1.

**STEP 2** - Press both buttons and hold for 6 seconds to power off the temperature control. See Figure 2.

**STEP 3** - Press bottom button and hold for 6 seconds to defrost. See Figure 3.

**STEP 4** - Press and release top or bottom button for 2 seconds to display cut out temperature.

Raise or lower the set point, use the top or bottom to go up or down. Release the button and temperature will go back. See Figure 4.

**STEP 5** - Press upper button and hold for 5 seconds to change temperature settings from °F to °C. See Figure 5.

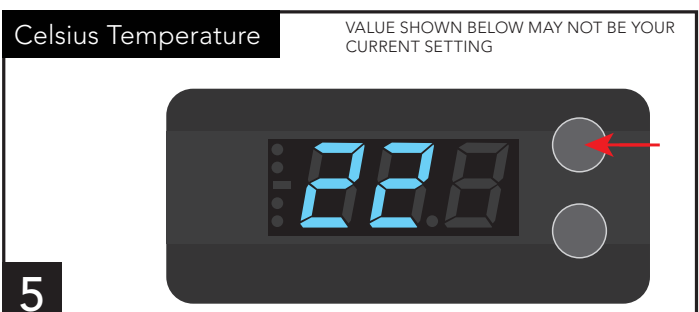
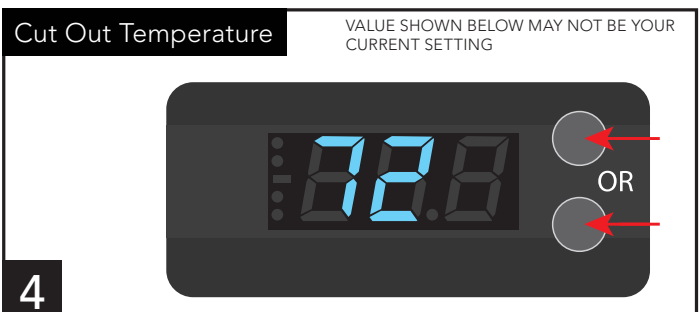
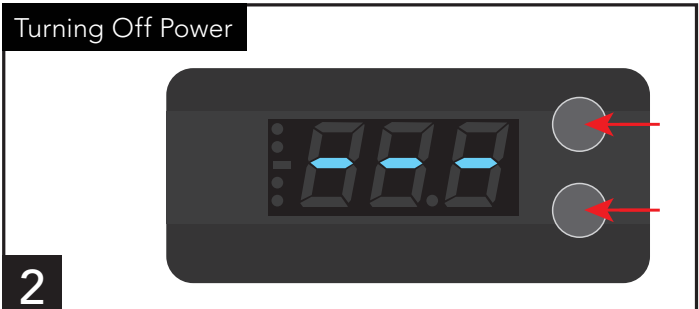
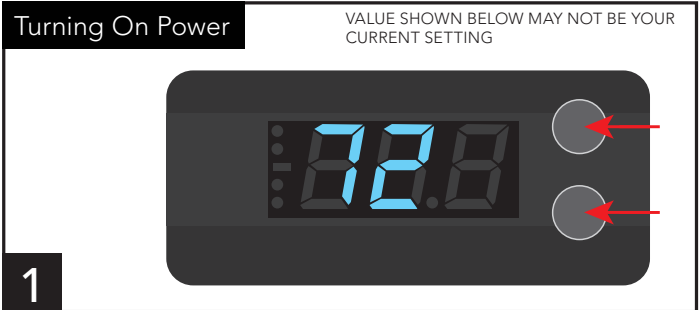

# DANFOSS ELECTRONIC TEMPERATURE CONTROLS

## HOW TO USE THE DANFOSS ELECTRONIC CONTROL

### ELECTRONIC TEMPERATURE CONTROLS - DANFOSS:

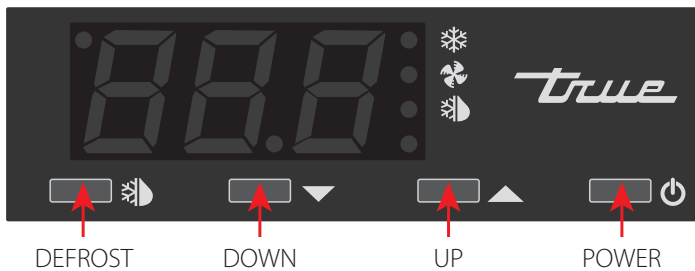
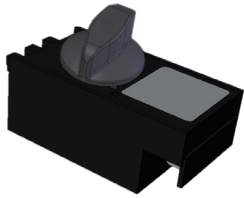





#### USING A DANFOSS ELECTRONIC CONTROL WITH DIGITAL DISPLAY:

**STEP 1** - Press the POWER button  for 5 seconds to power on the temperature control. See Figure 1.

**STEP 2** - Press the POWER button  for 5 seconds to power off the temperature control. See Figure 2.

**STEP 3** - Press the DEFROST button  for 3 seconds to defrost. See Figure 3.

**STEP 4** - Press the UP button  for 3 seconds to display the set point/cut-out temperature. Press the UP  or DOWN  button to raise or lower the temperature. See Figure 4.

**STEP 5** - Press the UP button  for 10 seconds, °F or °C will display. Press the UP button  to change from °F to °C. See Figure 5.

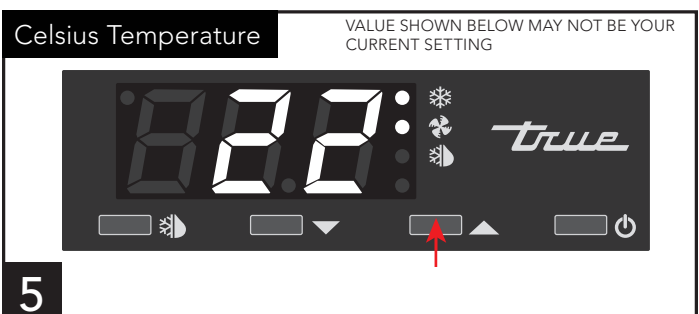
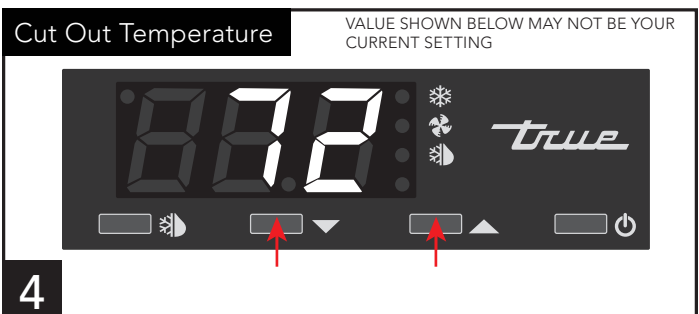
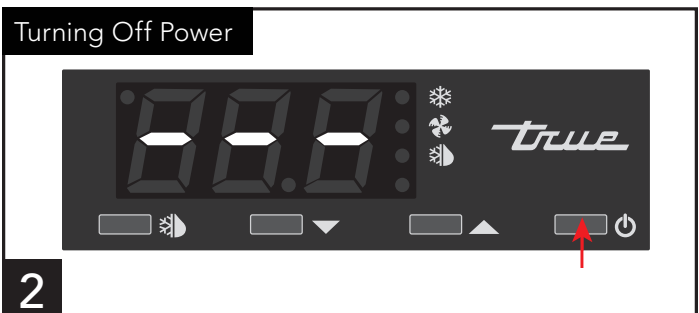
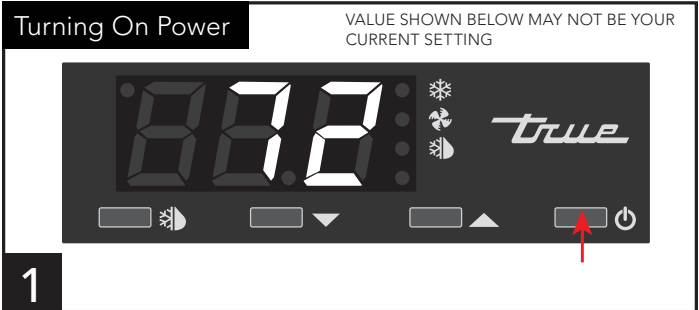

# DANFOSS ELECTRONIC TEMPERATURE CONTROLS

## DANFOSS CONTROL LEGEND

The diagram shows a control panel with a central digital display showing '00.0' and '°C'. To the left of the display are two buttons: a defrost/back button (snowflake with water droplets) and a power/okay button (power symbol). To the right of the display are two arrow buttons (up and down). The legend defines these buttons and other symbols:



- Defrost / Back / Show °F or °C
- Power / Okay
- Set Point / Up Arrow
- Set Point / Down Arrow
- Compressor Running
- Evaporator Fan Running
- Cabinet in Defrost
- Alarm

## DISPLAY CODES

Display	Definition	Display	Definition
E1	Sensor 1 Defect	ULo	Low Supply Voltage
E2	Sensor 2 Defect	UH <sub>i</sub>	High Supply Voltage
E4	Compressor Fault	H <sub>i</sub>	High Temperature Alarm
E5	Heater Fault	Lo	Low Temperature Alarm
E6	Pot Fault	E13	Communication Error





# DANFOSS ELECTRONIC TEMPERATURE CONTROLS

## DANFOSS CONTROL LEGEND

-  Defrost / Back / Show °F or °C
-  Power / Okay



-  Set Point / Up Arrow
-  Set Point / Down Arrow



-  Compressor Running
-  Evaporator Fan Running
-  Cabinet in Defrost
-  Alarm

### Unlock the Control

The display will not lock unless it was originally locked.

1. Press any button to display the current lock status.



2. If the display shows **unL**, the control is unlocked. If the display shows **Loc**, press and hold the back button  and the up arrow  until the display shows **unL**.



**NOTE:** The control will lock after 60 seconds of inactivity.

### Turn Off / On the Control

Turning off the control will deactivate all electrical components.



**CAUTION** – Turning off the control will not shut off power to the cabinet. Be sure to remove power to the cabinet prior to servicing.

#### Turn OFF

Press and hold the power  button until the display shows **OFF**. The display will then turn blank with a decimal point.



# DANFOSS ELECTRONIC TEMPERATURE CONTROLS

## DANFOSS CONTROL LEGEND

 Defrost / Back / Show °F or °C

 Power / Okay



 Set Point / Up Arrow

 Set Point / Down Arrow

 Compressor Running

 Evaporator Fan Running

 Cabinet in Defrost

 Alarm



### Turn ON

Press and hold the power button until the display shows **on**. The display will then show the current cabinet temperature.



### Change the Set Point

Changing the set point adjusts the cabinet temperature to keep optimal product temperature.

1. Press the up  or down  arrow to show the current setting.



2. Press the arrow buttons to change the set point to the desired temperature.





3. Leave the display inactive until it shows the current cabinet temperature.







# DANFOSS ELECTRONIC TEMPERATURE CONTROLS

## DANFOSS CONTROL LEGEND

-  Defrost / Back / Show °F or °C
-  Power / Okay



-  Set Point / Up Arrow
-  Set Point / Down Arrow

-  Compressor Running
-  Evaporator Fan Running
-  Cabinet in Defrost
-  Alarm

### Initiate Manual Defrost

A manual defrost clears accumulated frost and ice from the evaporator coil. The defrost will only terminate when a specific preset temperature or duration has been met.

Press and hold the defrost button  until the display shows **dEF**.



### Change Display Readout

The display can show the temperature in either Fahrenheit or Celsius.

Press the back button  to change the system of measure.



## TROUBLESHOOTING

Alarm Code	Comments
"Hi"	High temperature alarm
"Lo"	Low temperature alarm
"Con"	Condenser alarm
"dor"	Door open alarm
"uHi"	High voltage alarm
"uLi"	Low voltage alarm
"LEA"	Leakage alarm
"E01"	"S1" sensor failure (short or open)
"E02"	"S2" sensor failure (short or open)
"E03"	"S3" sensor failure (short or open)
"E04"	"S4" sensor failure (short or open)

Problem	Probable Cause
Compressor does not start	Waiting for compressor delay timer Defrost in progress Line voltage to compressor too low or too high
Fan does not start	Door is open or door contact is defective
Defrost does not start	Controller in pull down mode
Alarm does not sound	Alarm delayed
Display brightness is weak	Ambient light sensor broken
Shift between ECO and normal mode does not happen on ambient light change	Ambient light sensor broken or light level not set properly
Display alternates between condenser and temperature	Condenser too hot
Display alternates between high and temperature	Temperature too high
Display alternates between low and temperature	Temperature too low
Display shows "dEf"	Defrost in progress

# DANFOSS ELECTRONIC TEMPERATURE CONTROLS

## DANFOSS PROBES:

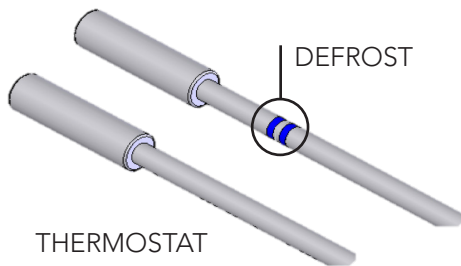

### Checking the probe resistance.

- Verify the probe resistance is accurate at the probe location.
  - Use a calibrated thermometer to check the probe location temperature (coil or air temperature).
  - Disconnect the probe from the controller. The probe cannot be plugged into the controller when measuring resistance.
  - Use a calibrated Ohm meter to measure the resistance of the probe
  - The resistance of the probe should match the associated temperature from the above table.
- Fill a cup full of ice water (use a lot of ice). Put the probe into the ice bath, stir for 1 minute, then measure the resistance with a calibrated Ohm meter. Make sure to keep the probe in the center of the cup.
  - The resistance of the probe should match the associated temperature at 32°F / 0°C degrees as shown in the above table.

Temperature		Resistance
C	F	K-ohm
-55	-67	487.89
-50	-58	338.25
-45	-49	237.69
-40	-40	169.16
-35	-31	121.80
-30	-22	88.77
-25	-13	65.34
-20	-4	48.61
-15	5	36.50
-10	14	27.68
-5	23	21.17
0	32	16.33
5	41	12.70
10	50	9.95
15	59	7.86
20	68	6.25
25	77	5.00
30	86	4.03
35	95	3.27
40	104	2.67

# DANFOSS ELECTRONIC TEMPERATURE CONTROLS

## DIAGNOSTIC FLOWCHART FOR ELECTRONIC CONTROLS WITH DIGITAL DISPLAYS

**Concern:** Electronic Control Display Temperature does not match the cabinet temperature

**NOTE:** The temperatures may reflect the refrigeration cycle determined by a set point and differential or it may show an average temperature. The temperatures are also effected by a defrost cycle and the open and closing of the door. The most accurate temperature on a cabinets operation is to verify the product temperature.

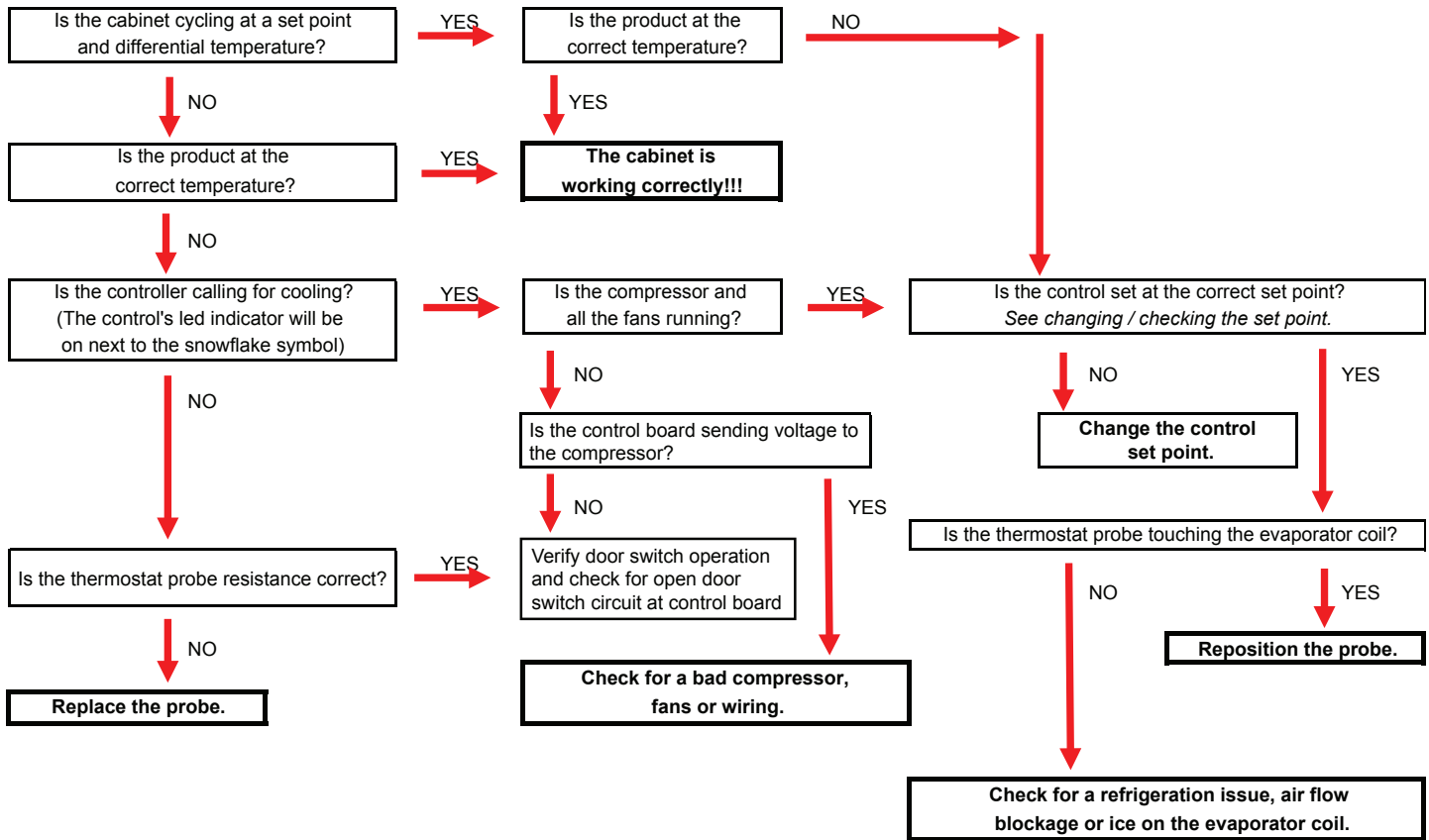



## SOLLATEK ELECTRONIC TEMPERATURE CONTROLS

Control version will vary with model and age of cabinet.

### SOLLATEK:

control probe = return air  
defrost probe = coil



### SOLLATEK ELECTRONIC PROBES:

**BLACK** - Thermostat  
**WHITE** - Defrost

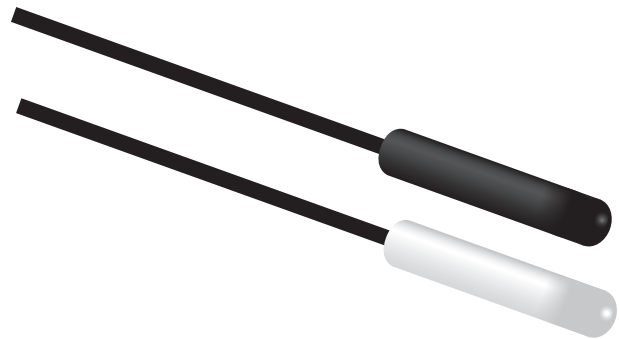

# SOLLATEK ELECTRONIC TEMPERATURE CONTROLS

## USING THE SOLLATEK ELECTRONIC CONTROL

### ELECTRONIC TEMPERATURE CONTROLS - SOLLATEK



#### USING A SOLLATEK ELECTRONIC CONTROL TO INITIATE DEFROST:

**STEP 1** - Set the temperature knob to position 0 when the unit is unplugged.

**STEP 2** - Power the unit up and the green LED will be ON alone.

**STEP 3** - Wait for one second, and rotate the knob slowly to position 4, the yellow LED will be ON alone.

**STEP 4** - Wait for one second, and rotate the knob slowly to position 2, the red LED will be ON alone.

**STEP 5** - Wait for one second, and rotate the knob slowly to position 8, all the LED's will be ON.

**STEP 6** - Wait for one second, and rotate the knob slowly away from marking 8, the defrost will be initiated.

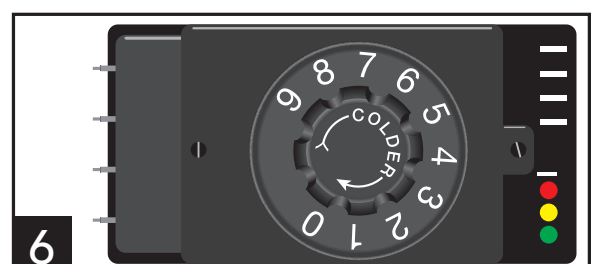
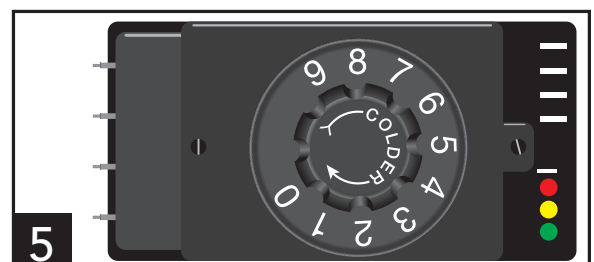
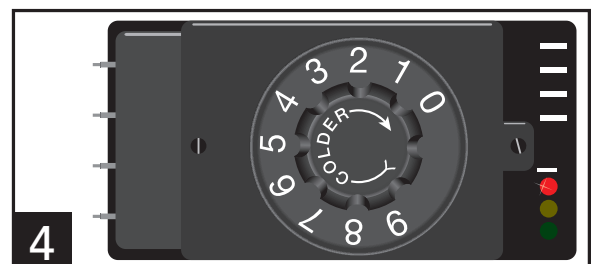
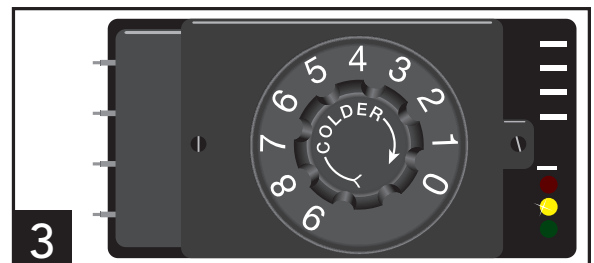
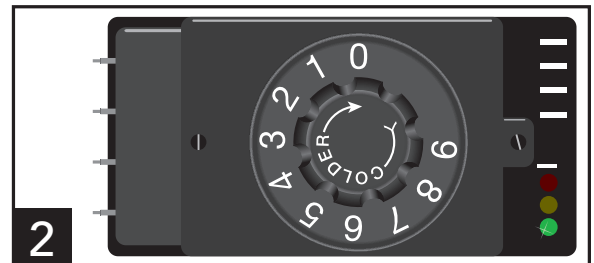
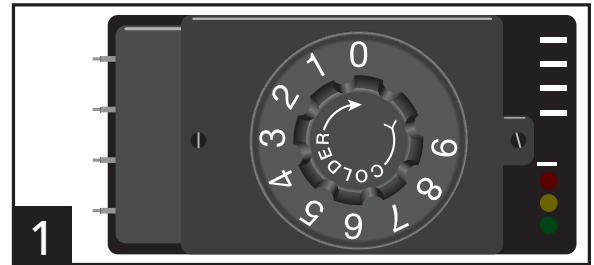

## SOLLATEK ELECTRONIC TEMPERATURE CONTROLS

### SOLLATEK ELECTRONIC PROBES:

**BLACK** - Thermostat

**WHITE** - Defrost

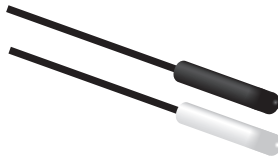

### Checking the probe resistance.

- Verify the probe resistance is accurate at the probe location.
  - Use a calibrated thermometer to check the probe location temperature (coil or air temperature).
  - Disconnect the probe from the controller. The probe cannot be plugged into the controller when measuring resistance.
  - Use a calibrated Ohm meter to measure the resistance of the probe
  - The resistance of the probe should match the associated temperature from the above table.
  
- Fill a cup full of ice water (use a lot of ice). Put the probe into the ice bath, stir for 1 minute, then measure the resistance with a calibrated Ohm meter. Make sure to keep the probe in the center of the cup.
  - The resistance of the probe should match the associated temperature at 32°F / 0°C degrees as shown in the above table.

## SOLLATEK ELECTRONIC TEMPERATURE CONTROLS

Sollatek Probe Temperature to Resistance Chart		
Temperature		Resistance
C	F	K-ohm
-10	14	548.267
-9	15.8	519.821
-8	17.6	492.994
-7	19.4	467.688
-6	21.2	443.81
-5	23	421.271
-4	24.8	399.992
-3	26.6	379.896
-2	28.4	360.911
-1	30.2	342.971
0	32	326.015
1	33.8	309.982
2	35.6	294.819
3	37.4	280.475
4	39.2	266.902
5	41	254.054
6	42.8	241.89
7	44.6	230.369
8	46.4	219.456
9	48.2	209.115
10	50	199.314
11	51.8	190.021
12	53.6	181.209
13	55.4	172.849
14	57.2	164.918
15	59	157.391
16	60.8	150.245
17	62.6	143.459
18	64.4	137.014
19	66.2	130.891
20	68	125.073
21	69.8	119.542
22	71.6	114.283
23	73.4	109.283
24	75.2	104.526
25	77	100

Sollatek Probe Temperature to Resistance Chart*		
Temperature		Resistance
C	F	K-ohm
26	78.8	95.692
27	80.6	91.592
28	82.4	87.687
29	84.2	83.969
30	86	80.427
31	87.8	77.051
32	89.6	73.835
33	91.4	70.768
34	93.2	67.844
35	95	65.055
36	96.8	62.395
37	98.6	59.857
38	100.4	57.434
39	102.2	55.122
40	104	52.914
41	105.8	50.805
42	107.6	48.79
43	109.4	46.866
44	111.2	45.026
45	113	43.268
46	114.8	41.587
47	116.6	39.98
48	118.4	38.443
49	120.2	36.972
50	122	35.564
60	140	24.386
70	158	17.035
80	176	12.11
90	194	8.75
100	212	6.419

\*Information is provided to verify cut-in/cut-out range for diagnostic purposes only.

# SOLLATEK ELECTRONIC TEMPERATURE CONTROLS

## HOW TO DIAGNOSE THE SOLLATEK ELECTRONIC CONTROL

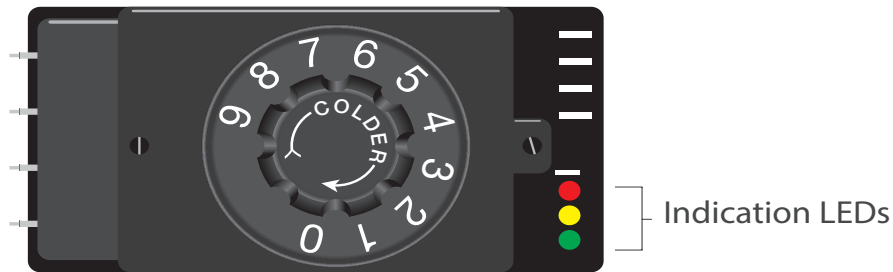

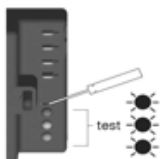
RED LED	YELLOW LED	GREEN LED	MEANING
OFF	OFF	ON	Voltage is good, compressor is ON, there is cooling demand.
ON	OFF	OFF	Voltage is bad, compressor is OFF, there is cooling demand.
Flashing	OFF	OFF	Voltage is bad, compressor is OFF, no cooling demand.
OFF	ON	OFF	In wait mode, compressor is OFF waiting for the time delay, there is cooling demand
OFF	Flashing	OFF	In wait mode, compressor is OFF waiting for the time delay, no cooling demand
OFF	OFF	Flashing	Time delay is over, compressor is OFF, no cooling demand.
ON	OFF	ON	In defrost mode, compressor is OFF.
Flashing	OFF	ON	In drip down mode, compressor is OFF.
Flashing	Flashing	OFF	Voltage frequency is bad, compressor is OFF.
OFF	Flashing	Flashing	Probe #1 is faulty.
OFF	Cycling	Cycling	Probe #2 is faulty.
Cycling	Cycling	Cycling	Knob is in the OFF position.
Flashing	Flashing	Flashing	Test mode. This forces the compressor ON for 10 seconds. Small screwdriver or any metallic object. 



## HST - HEALTH SAFETY TIMER

STARTUP _____	94
OPERATION _____	94
ELECTRONIC TEMPERATURE CONTROL GENERAL SEQUENCE OF OPERATION _____	95

## HST - HEALTH SAFETY TIMER

### STARTUP

#### Reason for Advisement

A UPS battery backup is included so temperatures can still be monitored and the lock can be actuated during a power outage.

The UPS is powered "off" when shipped from True and will need to be powered "on" upon start-up (see instructions on page 9).

The cabinet's Health Safety Timer feature will not be fully operation for 8 hours. This time is required for the UPS battery back up system to fully charge.

The UPS will provide power to the controller for a minimum of 2 hours.

When power is lost to the cabinet the UPS will beep and the control will display "**Pf**".

**NOTE:** The cabinet will lose its cooling capabilities when the power is lost.

When initial power is supplied to the cabinet, the control will indicate a delay.

The displayed on the control will alternate between "**hSt**" and "**dLy**".

This delay allows the cabinet to reach temperature without a false alarm. 60 minutes for a refrigerator and 105 minutes for a freezer.

If additional time or a delay event is needed, follow the directions titled "Enabling the Product Loading Delay and Servicing Delay".

### OPERATION

The Health Safety Timer cabinet's operation is determined by the electronic control.

The electronic control constantly monitors the cabinet temperature.

The control will activate a locking device when preset parameters of temperature (41°F - Refrigerator / 0°F - Freezer) are exceeded for a duration of 30 minutes. These parameters are pre-programmed.

When the temperature alarm is triggered, the door will mechanically lock and the control will provide a visual and an audible alarm. The displayed on the control will alternate between "**Loc**" and "**hLa**".

The alarm can be cleared by following the directions titled "Clearing the Health Safety Timer Alarm".

A key is required to reset the mechanical locking device and open the door once the Health Safety Timer has been activated.

**NOTE:** It is recommended to clear the alarm on the control first, otherwise door will re-lock when is closed again.

**NOTE:** In case of an emergency, the door may be opened from the inside with a pull cord.

If the door remains open for 5 minutes, as determined by the door switch, the control will provide a visual and an audible alarm. The displayed on the control will show "**do**".

Any audible alarm can be silenced by pressing the center "Enter/Confirm" button twice.

**NOTE:** Alarm will still be displayed on control until its condition has been corrected.

## HST - HEALTH SAFETY TIMER

### ELECTRONIC TEMPERATURE CONTROL GENERAL SEQUENCE OF OPERATION - HEALTH SAFETY TIMER (HST) MODELS

t1 = Thermostat

t2 = Defrost

t3 = Display Temperature



#### LAE CURRENT PROBES:

**GRAY** - Thermostat

**BLUE** - Defrost

**YELLOW** - Display

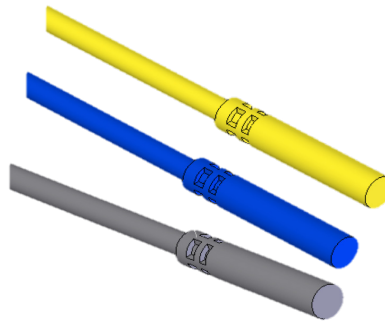

With remote control board.



# HST - HEALTH SAFETY TIMER



## DISPLAY LEGEND

LED INDICATORS		BUTTONS	
	Thermostat Output		Enter / Confirm
	Fan Output		Decrement / Lights
	Defrost Output		Increment / Eco Mode
	Keyboard Unlocked (*)		Exit / Standby
(*)	LED Off = Locked LED ON = Unlocked LED will blink to notify the key detection		Manual Defrost

### 1. TESTING THE HEALTH SAFETY LOCK (HST / TST)

1. Touch Enter twice to unlock the display.
2. Touch Enter again to display the main menu (**InF** will be the first item).
3. Touch Enter to display **hSt**.
4. Touch Enter to display the value **00**.
5. Touch + once to change the value to **23**.
6. Finally touch Enter.
7. Clear the health safety alarm.

### 2. CLEARING THE HEALTH SAFETY ALARM (LOC/HLA)

1. Touch Enter twice to unlock the display. This will also silence the alarm.
  2. Touch Enter again to display the main menu (**InF** will be the first item).
  3. Touch Enter to display the **hSt** submenu.
  4. Touch Enter to display the value **00**.
  5. Touch + once to change the value to **01**.
  6. Finally touch Enter.
- After 10 seconds the display will return to its normal state showing the cabinet temperature.

**NOTE:** Clearing the Health Safety Alarm through the display will not unlock the cabinet. The mechanical lock will require the use of the provided key.

## HST - HEALTH SAFETY TIMER



### DISPLAY LEGEND

LED INDICATORS		BUTTONS	
	Thermostat Output		Enter / Confirm
	Fan Output		Decrement / Lights
	Defrost Output		Increment / Eco Mode
	Keyboard Unlocked (*)		Exit / Standby
(*)	LED Off = Locked LED ON = Unlocked LED will blink to notify the key detection		Manual Defrost

### 3. ENABLING THE PRODUCT LOADING AND SERVICING DELAY (30 MINUTES FOR REFRIGERATOR AND 75 MINUTES FOR FREEZER)

This feature is to prevent locking when loading an empty cabinet.

1. Touch Enter twice to unlock the display.
2. Touch Enter again to display the main menu (**InF** will be the first item).
3. Touch Enter to display **hSt**.
4. Touch Enter to display the value **00**.
5. Touch **+** once to change the value to **23**.
6. Finally touch Enter.

- After 10 seconds the display will return to the delay state showing **hSt/dLY** alternating.

### 4. ADJUSTING THE SET POINT

1. Touch Enter twice to unlock the display.
2. Touch Enter again to display the main menu (**InF** will be the first item).
3. Touch either **-** or **+** to navigate the menu and find the SP item.
4. Touch Enter to display the set-point value\*.
5. Touch either **-** or **+** to increase / decrease the set point.
6. Touch Enter to save the new value.

- After 10 seconds the display will return to its normal state showing the cabinet temperature.

**NOTE:** The set-point value (SP) is NOT the cabinet holding temperature. To maintain proper operation within a safe temperature range and prevent an alarm activation, it is recommended to only change the value a few degrees.





# TRUE MANUFACTURING CO. INC.

## NORTH AMERICA - CANADA AND CARIBBEAN

Warranty Phone: +1 855 878 9277  
Warranty Fax: +1 636 980 8510  
Technical Phone: +1 855 372 1368  
Warranty Email: warrantyinquiries@truemfg.com

Technical Email: service@truemfg.com  
7:00-7:00 CST Monday-Thursday,  
7:00-6:00 Friday, 8:00-12:00 Saturday

## MEXICO

Phone: +52 555 804 6343/44  
Toll Free in Mexico: 01 800 202 0687  
service-mexicocity@truemfg.com  
9:00am – 5:30pm M-F

## LATIN AMERICA

Phone: +56 232 13 3600  
servicelatam@truemfg.com  
9:00am – 5:30pm M-F

## UK, IRELAND, MIDDLE EAST, AFRICA AND INDIA

Phone: +44 (0) 1709 888 080  
UK Freephone: 0 800 783 2049  
service-uk@truemfg.com  
8:30am – 5:00pm M-F

## EUROPEAN UNION AND COMMONWEALTH OF INDEPENDENT STATES

Phone: +49 (0) 7622 6883 0  
servicedepteu@truemfg.com  
8:00am – 5:00pm M-F

## AUSTRALIA

Phone: +61 2 9618 9999  
service-aus@truemfg.com  
8:30am – 5:00pm M-F

## The Industries Most Complete Refrigeration Source

# TEMPERATURE CONTROL ADJUSTMENTS CABINET SEQUENCE OF OPERATIONS

A TEMPERATURE CONTROL OR THERMOSTAT IS A DEVICE THAT IS INTERPOSED IN A COOLING SYSTEM BY WHICH TEMPERATURE IS AUTOMATICALLY MAINTAINED BETWEEN CERTAIN LEVELS.



truemfg.com